

# XHH Solar Panel Installation Operation

## 1. INTRODUCTION

As the leader in high photovoltaic technology applications, XinHongHua has stepped into the forefront in development of multicrystalline solar modules. XinHongHua began researching photovoltaics in 2002 and dedicated to research ,develop and manufacture of Solar Photovoltaic Technology. We have imported full set of Production Technology and devices from abroad for PV Module Making. Our Products Lines refer to Monocrystalline , Polycrystalline ,and Amorphous with various specification and high efficiency Large Scale PV Module and Mini PV Module. ShenZhen XinHongHua in possession of abundant High Technology and Advanced Testing Device, do research by ourselves and with strong production capacity, daily capcacity for various specification PV Module around 60,000Watts, and annual is near to20MW. And We also customized PV Module as client's request and provide OEC&ODM services.Provide full set Solar Sytem ( including Off-Grid and Gird Connection System) is also withinour business scope. Our Production are widely used in Navigation, Spaceflight, MicroWave Tower, Television Rebroadcasting Tower, Data Collection, also provide off-gird solar system to romoted ares and Grid Connection Solar System.

## 2. POWER MODULES

XinHongHua series modules come in various sizes to satisfy a full range of applications. Each module is made of multi- crystalline cells manufactured by the "casting" method. These cells cover nearly 100% of the module's surface. To protect the cells from the most severe-environmental conditions, they are encapsulated between a tempered glass cover and an EVA pottant with PVF back sheet. The entire laminate is installed in an anodized aluminum frame for structural strength and ease of installation.

## 3. APPLICATIONS

XHH modules are a reliable, virtually maintenance free power supply, designed to operate efficiently in sunlight. XinHongHua solar modules are ideal for charging storage batteries used to power remote homes, recreational vehicles, boats, telecommunication systems and other electric generation application.

## 4. MOUNTING SITE SELECTION

The solar modules should be mounted in a location where they will receive maximum sunlight throughout the year. In the Northern Hemisphere, the modules should face south, and in the Southern Hemisphere, the modules should face north. Modules facing 30 degrees away from true South (or North) will lose approximately 10 to 15 per cent of their power output. If the module faces 60 degrees away from true South (or North), the power loss will be 20 to 30 per cent. When choosing a site, avoid trees, cast shadows on the solar modules especially during the winter months when the arc of the sun is lowest over the horizon.

## 5. MODULE TILT ANGLE

Solar modules produce the most power when they are pointed directly at the sun. For installations where the solar modules are mounted to a permanent structure the solar modules should be tilted for optimum with performance. As a rule, if the system power production is adequate in the winter, it will be satisfactory during the rest of the year. The module tilt angle is measure between the solar modules and the ground (Figure 1).

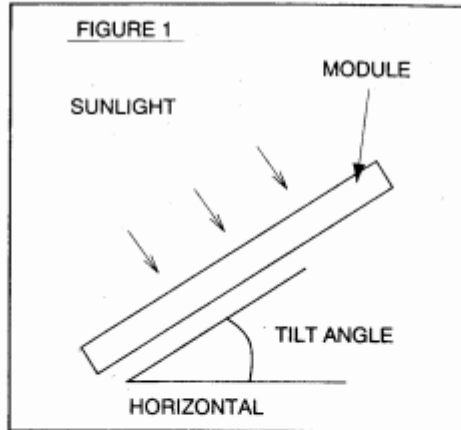

RECOMENDED TILT ANGLES FOR A FIXED SYSTEM	
SITE LATITUDE IN DEGREES	FIXED TILT ANGLE
0° TO 15	15°
15° TO 25°	SAME AS LATITUDE
25° TO 30°	LATITUDE + 5°
30° TO 35°	LATITUDE + 10°
35° TO 40°	LATITUDE + 15°
40° +	LATITUDE + 20°

## 6. MOUNTING THE MODULE

The frame of each module has fourteen 7 mm  $\varnothing$  diameter mounting holes (Figure 2). These are used to secure the modules to the supporting structure. The example of a ground mounted structure is shown in Figure 3. The four holes close to the corners of the module are most often used for mounting. Clearance between the module frame and the mounting surface may be required to prevent the junction box from touching the surface, and to circulate cooling air around the back of the module. In case the modules will be mounted on the roof or wall of a building, the standoff method or the rack method are recommended. **STANDOFF:** The modules are supported parallel tthe surface of the building wall or roof. Clearance between the module frames and surface of the wall or roof is required to pre- vent wiring damage and to allow air to circulate behind the module. (about 115 mm) The recommended standoff height is 4.5 in. If other mounting means are employed, this may affect the Listing For Fire Class Ratings. **RACK:** The supporting frame is used to mount modules at correct tilt angles. The modules are not designed for integral

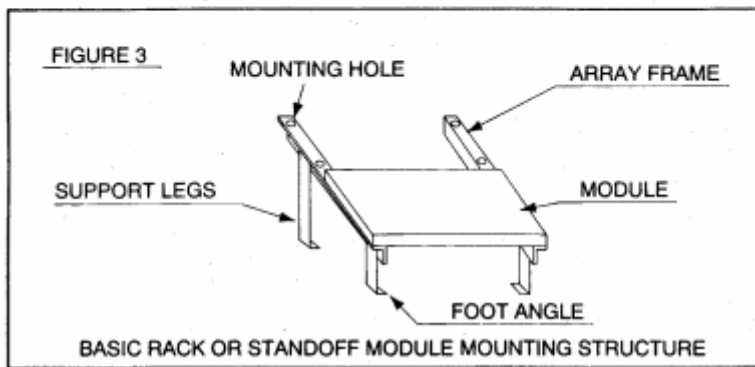
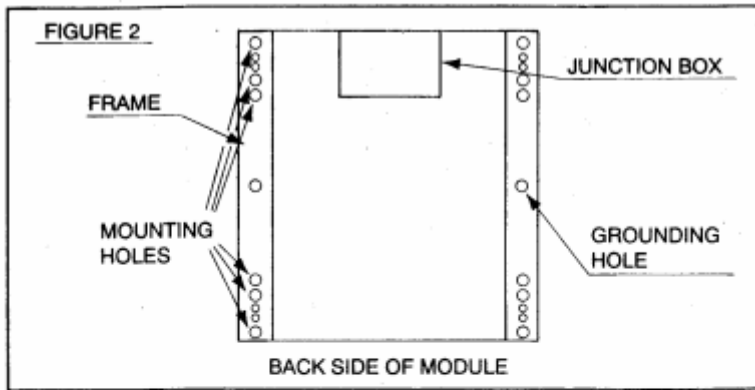

m mounting as part of a roof or wall. The mounting design may have an impact on the fire resistance.

## 7. WIRING

Most of the larger XinHongHua Modules use the "G" or "M" type junction box. This box, on the back side of the module, is weatherproof and is designed to be used with standard wiring or conduit connections. Wiring methods should be in accordance to the NEC (National Electrical Code). Bypass diodes and cable clamps are included with each module when shipped from the factory.

A. Open the "G" or "M" box cover .

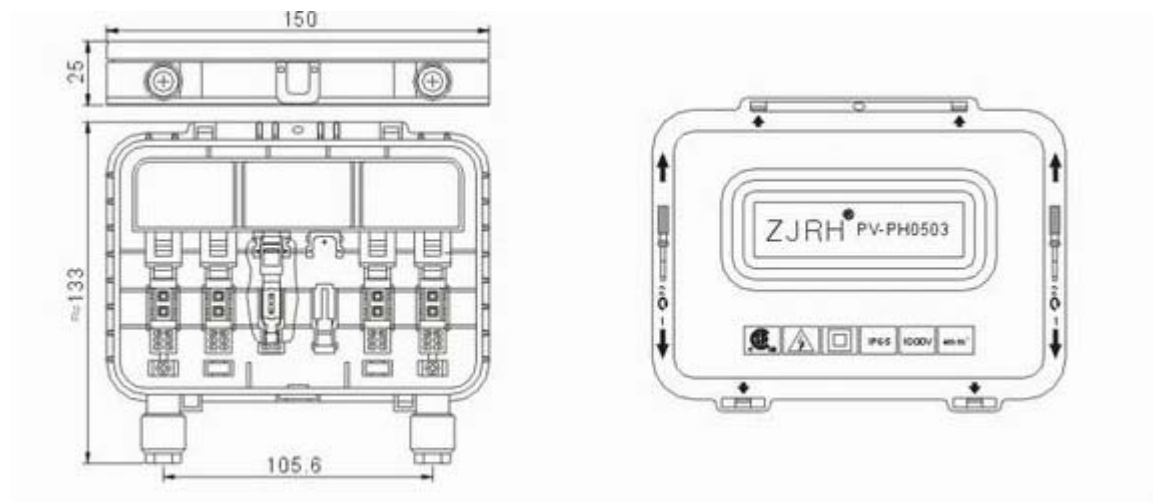

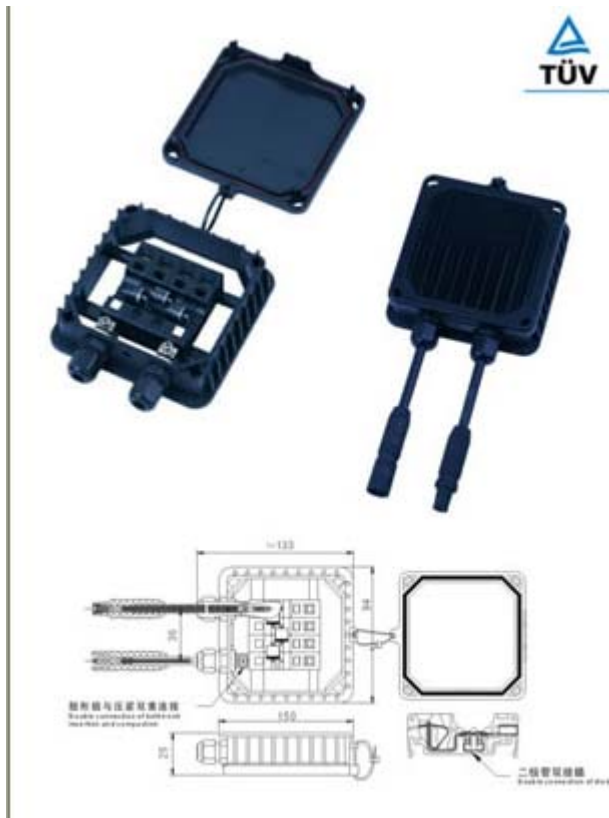

B. The wire typically used to interconnect the solar modules should be single or two conductor, from 10 AWG(5.26 mm<sup>2</sup>) up to 14 AWG(2.08 mm<sup>2</sup>) gauge stranded copper wire, in a "SUNLIGHT RESISTANT" jacket UF cable. This cable is suitable for applications where wiring is exposed to the direct rays of the sun. The maximum and minimum diameter of the cable that may be used with the cable connector are 8 mm and 6 mm respectively.

C. Remove approximately 1/2 of insulation on the ends of the wires and insert them under the appropriate "POSITIVE" or "NEGATIVE" terminal screws in the junction box. The wires should be installed with some slack; excess wire should be cut off. Install cable with appropriate hardware in accordance with NEC Article 250 or national and international rules.

D. Gently tighten the terminal screws. Do not overtighten, as the terminal can be damaged.

E. The output wiring from the final module is generally run to a separate array junction box. In commercial system, this wiring from the array box to the next component (i.e. fuse box. or charge regulator, etc.) is generally run in conduit. The maximum electrical rating of an acceptable series fuse is 4 ~ 12 amperes.

F. After completing the wiring between all boxes, Close and secure all the junction boxes.

## 8. GROUNDING

We recommend you attach all module frames to an earth ground. Attach a separate ground wire to one of the extra mounting holes on the module frame with a self-tapping screw. The racks must also be grounded unless they are mechanically connected by nuts and bolts to the grounded modules. Grounding is achieved by securing the array frame for both roof and field mounted applications. Additionally, the array frame shall be installed in accordance with NEC Art 250.

## 9. BLOCKING DIODES

Blocking diodes can prevent nighttime battery discharging caused and prevent modules from loss of array output and being damaged or destroyed by reverse current flow. XINHONGHUA modules do not contain a blocking diode when shipped from the factory, however most battery charging regulators do have this feature.

## 10. BYPASS DIODES

Partial shading of an individual module in a 12 volt or higher "series" string (i.e. two or more modules) can cause a reverse voltage across the shaded module. Current is then forced through the shaded area by the other modules in series. By having a bypass diode, the forced current will bypass the shaded module in a series circuit, thereby minimizing module heating and array current losses. For 12-volt systems and higher: Each solar module junction box has a diagram illustrating the proper direction for the by-pass diode to be installed between two of the terminal screws (Figure 11, Figure 12). When the solar modules are connected as individual series strings first, and then these strings are connected in parallel, bypass diodes should be used in each junction box. This is the simplest wiring arrangement for most installations.

At a minimum the bypass diodes must have the following electrical characteristics:

Rated Average Forward Current [I] Above maximum system current at highest operating temperature.

Rated Repetitive Peak Reverse Voltage [V] Above maximum system voltage at lowest operating temperature.

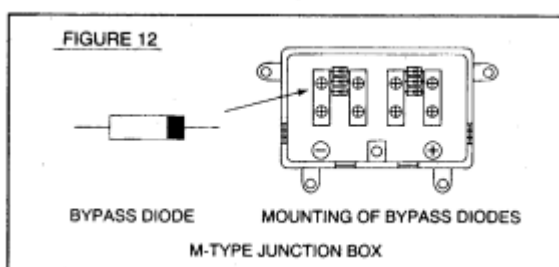
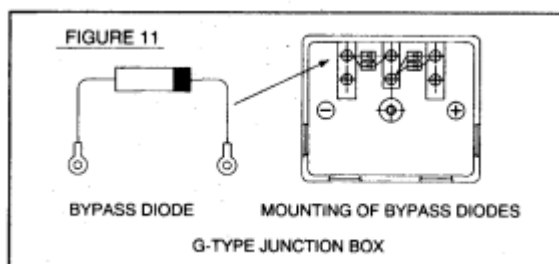

## 11. MAINTENANCE

Solar modules require very little maintenance. It is not uncommon for a remote site to be checked but once per year. Under most conditions, normal rainfall is sufficient to keep the module glass clean. If dirt build-up becomes excessive, clean the glass with a soft cloth using mild detergent and water. Modules that are mounted, flat (0° tilt angle) should be cleaned more often, as they will not "self clean" as effectively as modules mounted at a 15° tilt angle or greater. Once a year, check the tightness of terminal screws and the general condition of the wiring. Also, check to be sure that mounting hardware is tight. Loose bolts could result in a damaged module or array.

## 12. WARNINGS

Solar modules are live electrical power sources when exposed to light. Arrays of many modules can cause lethal shock and burn hazards. Solar modules should be covered with an opaque material during installation to avoid shocks or burns. Do not touch live terminals with bare hands. Use insulated tools for electrical connections.

### **PERMIT ( if Grid Solar System)**

- Before installing your solar system, contact local authorities to determine the necessary permit, installation and inspection requirements.

### **INSTALLATION AND OPERATION**

1. Systems should be installed by qualified personnel only. The system involves electricity, and can be dangerous if the personnel are not familiar with the appropriate safety procedures.

2. Do not step on the module.

3. Although XINHONGHUA modules are quite rugged, the glass can be broken (and the module will no longer work properly) if it is dropped or hit by tools or other objects.

4. Sunlight shall not be concentrated on the module.

5. The module frame is made of anodized aluminum, and therefore corrosion can occur if the module is subject to a salt water environment with contact to a rack of another type of metal. (Electrolytic Corrosion)

### **GROUNDING**

All module frames and mounting racks must be properly grounded in accordance with the appropriate electrical codes.

### **INSPECTION**

Follow the requirements of applicable National and local electrical safety Codes.

### **BATTERY**

When solar modules are used to charge batteries, the battery must be installed in a manner which will protect the performance of the system and the safety of its users. The battery should be away from the main flow of people and animal traffic. Select a battery site that is protected from sunlight, rain, snow, debris, and is well ventilated. Most batteries generate hydrogen gas when charging, which is explosive. Do not light matches or create sparks near the battery bank. When a battery is installed outdoors, it should be placed in an insulated and ventilated battery case specifically designed for the purpose.