

3.5 - DIGIT WATCH CIRCUIT FOR DUPLEXED LCD

GENERAL DESCRIPTION

The An8299 is low threshold voltage , ion implanted polysilicon gate CMOS IC, which provides all signal to drive a duplexed 3.5-digit liquid crystal display with colon.

FUNCTIONS

- 6 Functions: month, date, hour, minute and second.
- Selective alternation of time-date display mode.
- One-touch correction of time error within 30 seconds.
- 4-year calendar.
- 2-switch sequential operating.
- LCD test.

FEATURES

- **Simple Application circuit**
- Single-chip CMOS construction
- Drives 3.5-digit duplexed LCD
- Low power dissipation
- Colon display
- 32,768Hz \pm 120ppm (mask option) crystal controlled operation
- Single 1.5V battery operation
- Full on chip voltage doubler
- Debounce circuitry on switch input
- ESD protection up to 4000 V
- Built-in crystal oscillator network input and output capacitor

ABSOLUTE MAXIMUM RATINGS (Ta=25°C)

| Characteristic | Symbol | Value | Unit |
|--|------------------|-----------|------|
| Supply Voltage (V _{DD} ~V _{SS}) | V _{GG} | -0.3~+3.0 | V |
| Operating Temperature | T _{OPP} | -20~+75 | °C |
| Storage Temperature | T _{STG} | -55~+150 | °C |

ELECTRICAL CHARACTERISTICS

(Ta=25°C, V_{DD} =0V, V_{SS} =1.5V, unless otherwise specified)

| Characteristic | Symbol | Test conditions | Min | Typ | Max | Unit |
|----------------------------|------------------|----------------------------------|----------------------|-------|-----------------|------|
| Operating Voltage | V _{SS} | | 1.2 | 1.5 | 1.8 | V |
| Supply Current | I _{DD} | Without load | | 1.2 | 1.5 | μA |
| Input Low Voltage | V _{IL} | | V _{SS} +0.3 | | V _{SS} | V |
| Input High Voltage | V _{IR} | | -0.3 | | 0 | V |
| Switch Activation Current | I _{SW} | V _{IN} =V _{DD} | 0.1 | 1.0 | 10 | μA |
| Oscillator Start Voltage | V _{OSC} | Within 5 sec | | | 1.45 | V |
| Oscillator Stop voltage | V _{OSP} | | | | 1.15 | V |
| Osc.input/output Capacitor | OI/OO | | | 20/20 | | pF |
| LCD Frequency | FD | | | 32 | | Hz |
| SW Debouncing Time | TD | | | | 62.5 | msec |

LCD FORMAT

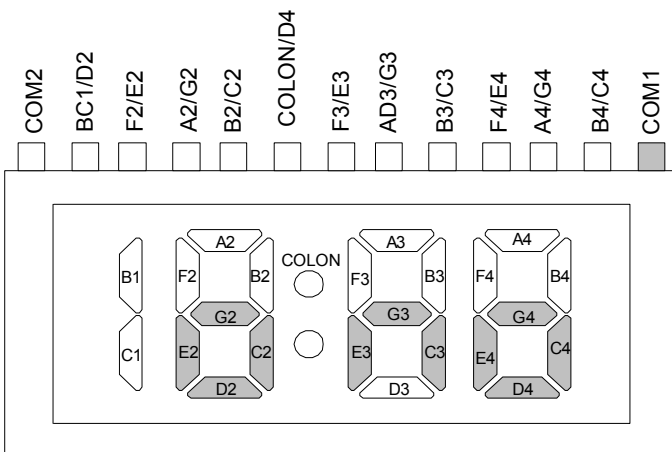

PAD DESCRIPTION AND BONDING PAD DIAGRAM

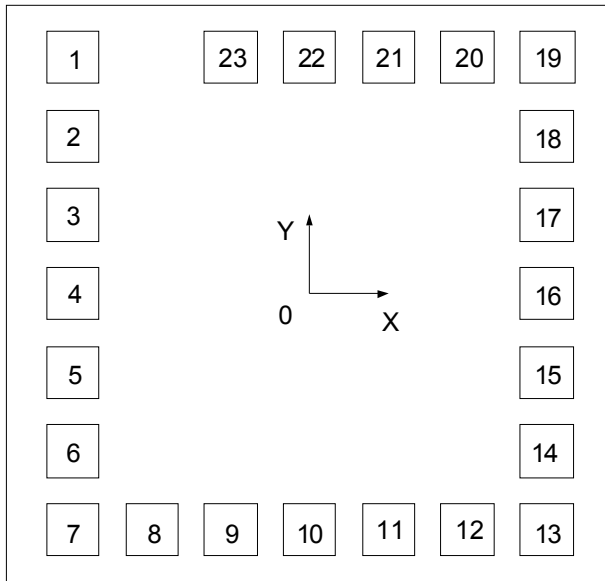

Chip size: 1310 x 1230 μm

Pad size: 110 x 110 μm

Pads 20÷23 is not bonding

| Pad | Pad Name | Description | X | Y |
|-----|-----------------|-----------------------|------|------|
| 1 | Vss | Power supply negative | -505 | 465 |
| 2 | S | Control Switch | -505 | 315 |
| 3 | D | Control Switch | -505 | 165 |
| 4 | COM1 | Common | -505 | 15 |
| 5 | B4/G4 | Segment Output | -505 | -135 |
| 6 | A4/G4 | -- | -505 | -285 |
| 7 | F4/E4 | -- | -505 | -465 |
| 8 | B3/C3 | -- | -346 | -465 |
| 9 | AD3/G3 | -- | -196 | -465 |
| 10 | F3/E3 | -- | -46 | -465 |
| 11 | COL/D4 | -- | 117 | -465 |
| 12 | B2/C2 | -- | 267 | -465 |
| 13 | A2/G2 | -- | 505 | -465 |
| 14 | F2/E2 | -- | 505 | -285 |
| 15 | BC/D2 | -- | 505 | -135 |
| 16 | COM2 | Common | 505 | 15 |
| 17 | IN | Oscillator input | 505 | 165 |
| 18 | OUT | Oscillator output | 505 | 315 |
| 19 | V _{DD} | Power supply positive | 505 | 465 |
| 20 | V _{EE} | Doubled Voltage | 372 | 485 |
| 21 | IT1 | Test Pin 1 | 178 | 485 |
| 22 | IT2 | Test Pin 2 | 30 | 485 |
| 23 | IT3 | Test Pin 3 | -90 | 485 |

TYPICAL APPLICATION CIRCUIT

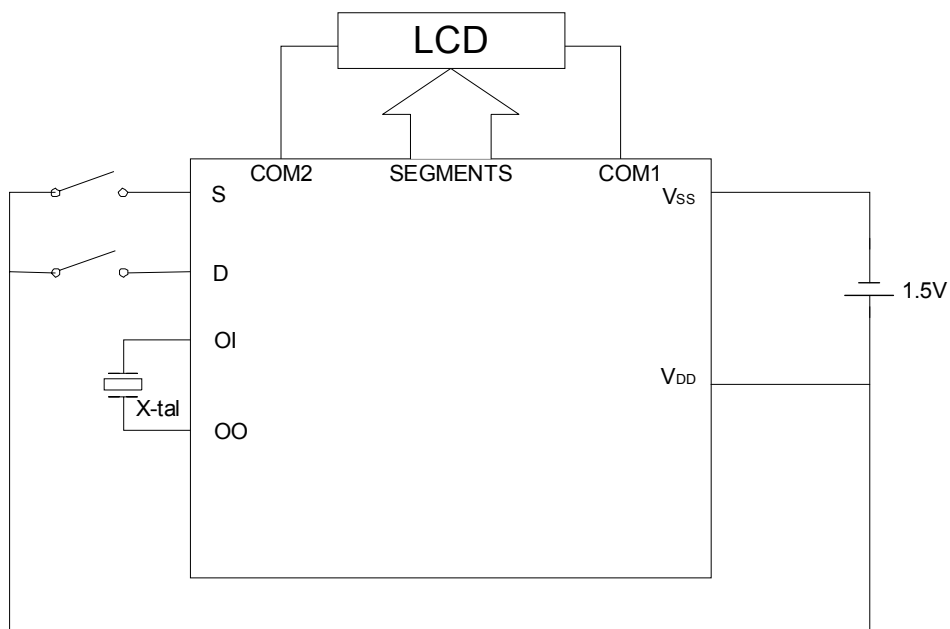

Substrate of chip is connected to V_{DD}

| Version | Chip Label | Quartz Condition |
|---------|------------|------------------------|
| 1 | 8299 -11 | X-tail 32768 Hz -20ppm |
| 2 | 8299 -12 | Standard X-tail |
| 3 | 8299 -13 | X-tail 32768 Hz +20ppm |