

# Norman 4500, 14500, 34500 & 54500 Series Tee-Type Filters

Up to  
20,000 PSI

- Aluminum or Stainless Steel Housings
- Single or Dual Stage
- Stainless, Glass Fiber, Sintered or Cellulose Elements



**NORMAN FILTER COMPANY, L.L.C.**

PHONE: 708-233-5521 • FAX: 708-430-5961

[www.normanfilters.com](http://www.normanfilters.com)

# NORMAN TEE-TYPE FILTERS

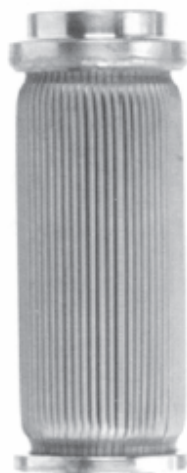

Choice of Elements

- Cellulose
- Glass Fiber
- Stainless Steel
- Porous Sintered Stainless



Choice of Housing Material

- Aluminum
- Stainless Steel

• All pressure ratings and seal configurations have been tested with hydraulic fluid any other fluid or gas please consult factory before installation.

## FLUID CONDITIONERS

Norman Tee-Type filters are used to condition a wide variety of fluids. Whether your application is hydraulic, pneumatic, chemical processing, compressed gases or industrial fluid clarification, Norman filters will remove particulate contaminants from your system to keep it running longer. Filters increase the life of the pumps, valves, regulators and other components in your system, with pay-backs of longer system life, reduced down-time, and improved productivity. Norman offers the broadest filter line in the industry. This wide variety of sizes, materials, filtration media and optional accessories, all available from stock, allows you to select the model with the best price/performance value for your application.

## HOUSINGS

Norman Tee-Type filter housings are made of either aluminum or stainless steel. Aluminum pressure vessels are rated at 5000 PSI (operating), and offer light weight and low cost; our stainless steel housings have higher operating pressures (up to 20,000 PSI) and excellent corrosion resistance. These housings come in five basic sizes, with flow rates up to 50 GPM (with 100 SSU oil), or 4000 SCFM @ 3000 PSI, GN<sub>2</sub>). Port sizes range from 1/4" to 1 1/2" female pipe thread (FPT), or 1/2" to 1 1/2" female O-ring thread (SAE). High-pressure portings and weldments are available on 10,000, 15,000 and 20,000 PSI models. NOTE: All pressure ratings are static, for applications calling for pulsating or pressure spikes, consult factory.

## ELEMENTS

The replacement element is the heart of the filter. Norman offers four media types in a variety of micron ratings, with both low and high-collapse construction. In addition, six O-ring materials are available, most at no additional charge, to assure compatibility with virtually any fluid.

**CELLULOSE:** Resin-impregnated cellulose media has low cost and disposable convenience. Being a depth-type filter, it has high dirt-holding capacity for long life. Available in 3, 10 and 25 micron efficiency ratings with collapse pressures of 150 and 300 PSID. All Norman cellulose elements are bonded with epoxy for excellent fluid compatibility.

**GLASS FIBER:** Multi-layered glass fiber elements use aerospace technology to produce high efficiency silt-control filtration. Available in 1, 3, 5, 10 and 25 micron ratings, absolute (Beta<sub>x</sub> = 200), with collapse ratings of 300 and 3250 PSID. All are epoxy bonded. Its low flow restrictions and extremely long life (200 to 300% greater than cellulose) provide for extended service intervals and reduced maintenance cost.

**STAINLESS STEEL:** Our precision woven 304 stainless steel wire mesh elements provide absolute size discrimination and freedom from media migration. Available in nine micron ratings from 2X to 200μ, absolute (beta<sub>x</sub> = 75), all-welded construction, with collapse rating of 4500 PSID. These elements are most suited to extreme temperature ranges and corrosive conditions. Stainless steel elements are reusable, with proper cleaning they can be reused almost indefinitely.

**316 SINTERED METAL:** Now available in .5, 1, 3 and 7 micron absolute, 316 sintered metal elements. These elements are perfectly suited for low viscosity fluid and all gas applications.

## DUAL ELEMENTS

Norman Tee-Type filters are available in a unique dual-element configuration. The outer element is low-cost disposable cellulose for inexpensive system clean-up, and the inner element is recleanable stainless steel for absolute particulate retention. Dual-element filters combine very high dirt holding capacity and positive non-bypass filtration with the convenience of a low-cost replacement element.

## OPTIONAL ACCESSORIES

Norman Tee-Type filters have a number of optional accessories in stock to modify our standard housings to meet your specific application requirements:

**Visual Indicator:** Signals when the element needs changing. Reduces maintenance costs caused by premature element change-out.

**Electrical Switch:** Similar to visual indicator, above, but with a microswitch (normally open) and standard conduit connection. Used to actuate warning light, buzzer, etc., to signal element clogging.

**Bypass Relief Valve:** Internal valve relieves pressure during flow surges or cold start-up. Recommended with low-collapse elements.

**Pressure Taps:** Gauge ports on the inlet and outlet of the filter for external differential pressure sensing devices.

**Bowl Drain:** Allows liquid to be drained from the bowl to facilitate element change-out.



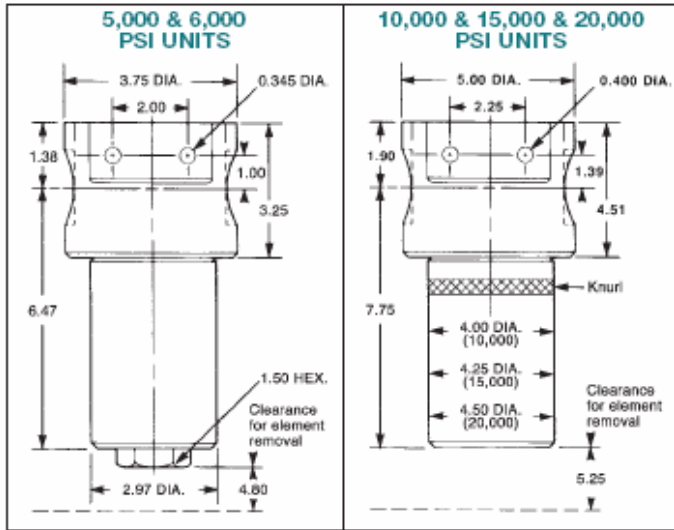

## SPECIFICATIONS

Rated Flow @ 10 PSID, clean (max.):  
 10 GPM (w/100 SSU oil)  
 300 SCFM (@ 3,000 PSI, GN<sub>2</sub>)

Housing Material:  
 5,000 PSI Units:  
 7075T6 Aluminum  
 6,000 PSI Units:  
 303 & 316 Stainless Steel  
 10,000 PSI Units: 17-4 PH, 316LSS  
 15,000 PSI Units: 17-4 PH, 316LSS  
 20,000 PSI Units: 17-4 PH

Pressure Ratings:  
 5,000 PSI Units:  
 5,000 PSI Operating  
 7,500 PSI Proof  
 20,000 PSI Burst  
 6,000 PSI Units:  
 6,000 PSI Operating  
 9,000 PSI Proof  
 24,000 PSI Burst

10,000 PSI Units:  
 10,000 PSI Operating  
 15,000 PSI Proof  
 40,000 PSI Burst  
 15,000 PSI Units:  
 15,000 PSI Operating  
 22,500 PSI Proof  
 60,000 PSI Burst

Pressure Ratings (continued):

20,000 PSI Units:  
 20,000 PSI Operating  
 30,000 PSI Proof  
 80,000 PSI Burst  
 O-Ring Temperature Range:  
 Buna-N: -40°F to +250°F  
 Viton: -20°F to +350°F  
 Ethylene Propylene: -65°F to +300°F  
 Teflon: -320°F to +400°F  
 Kalrez: -40°F to +600°F

Element Temperature Range:  
 Cellulose: -65°F to +275°F  
 Glass Fiber: -70°F to 350°F  
 304 Stainless: -425°F to 1,000°F

Options:  
 Relief Valve Setting: 50 PSID  
 Visual Indicator Setting: 40 PSID  
 Electrical Indicator Setting: 40 PSID  
 Electrical Indicator Current Rating:  
 0.5 Amps Resistive

Total Assembly Weight:  
 Aluminum 4 1/4 Lbs.  
 Stainless Steel: 12 Lbs.  
 10K, 15K, & 20K Stainless: 39 Lbs.

T.M. DuPont Corp

## HOW-TO-ORDER

Pressure	Port Size, Type	Housing Material	Element Code	Micron Rating	Collapse Rating	O-Ring Material	Optional Accessories
45 5000 psi	16R 1" NPT	A Aluminum**	A Cellulose	Code Nom. Abs. G A F P	P 150# Cellulose	L Buna-N	DR-1 1/8" NPT Bowl Drain*
45 6000 psi	16S 1" SAE (-16)	G 303 Stainless	D Dual*	.5 .2 .5	R 300# Cellulose	N Viton	DR-2 1/4" NPT Bowl Drain*
145 10000 psi	25 3/4" FPT	T 316 Stainless*	F Glass Fiber	1 .5 1	A 300# Glass Fiber	E Ethylene Propylene	DR-3 1/8" SAE Bowl Drain*
345 15000 psi	32 1/4" FPT	** SK Only	G Stainless Mesh	2X .2 10 *	C 2000# PSS	M Teflon™	DR-4 1/8" SAE Bowl Drain*
545 20000 psi	35 1/2" FPT	* 8K, 10K, 15K	P 316 Striated	B1 - 1 1 *	F 4500# Stainless Mesh	K 90 Durometer Nitrile	DRCT4 1/4" MP Bowl Drain
	45 1/2" SAE (-8)			B3 - 3 3 *		H Kalrez™	DRCT6 3/8" MP Bowl Drain
	75 3/4" SAE (-12)			3 .1 3 3 *			EE 40 psid Elec. Switch*
	250 1/4" Medium Pressure*			08 3 10 *			EER Switch + Valve*
	375 3/8" Medium Pressure*			06 5 18 *			R 50 psid Valve
	582 9/16" Medium Pressure*			B5 - 5 5 *			S1 1/8" NPT DP Ports*
	750 3/4" Medium Pressure*			7 7 7 *			S2 1/4" NPT DP Ports*
	4.8 1/4" SAE (-4)			10 10 25 *			S3 1/8" SAE DP Ports*
	6S 3/8" SAE (-6)			B10 - 10 10 *			S4 1/4" SAE DP Ports*
				20 20 40 *			SCT4 1/4" MP DP Ports
				25 25 40 *			SCT6 3/8" MP DP Ports
				B25 - 25 25 *			V 40 psid Indicator*
				40 40 75 *			VR Indicator + Valve*
				100 100 200 *			
				200 200 300 *			

\*10K, 15K & 20K Only  
 Note: SAE port not recommended over 6000 psi.  
 Socket weld ports available on special order.

Teflon and Kalrez are registered trademarks of DuPont.

\* Not available on 20K

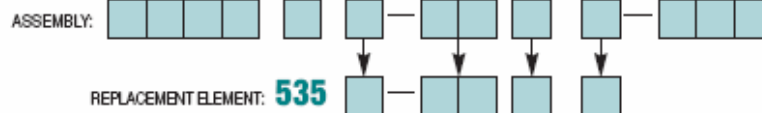

## FLOW DATA (PRESSURE DROP vs. FLOW)

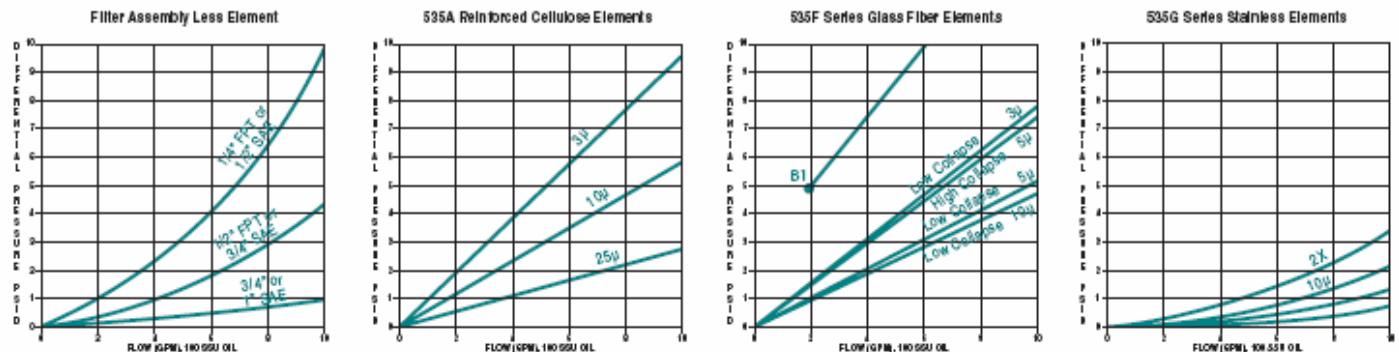

**NOTE:** Add pressure drop of the housing to that of the element to obtain total initial clean pressure drop of the assembly. To determine pressure drop for a different viscosity and density fluid, use the following conversion factor:

$$\text{New } \Delta P = \Delta P @ 100 \text{ SSU} \times \frac{\text{new viscosity, SSU}}{100 \text{ SSU}} \times \frac{\text{new spec. gravity}}{0.9}$$

