

1. 外形尺寸 Dimensions

单位(Units):毫米(mm)

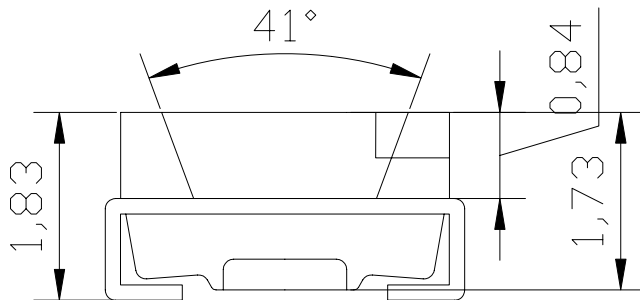
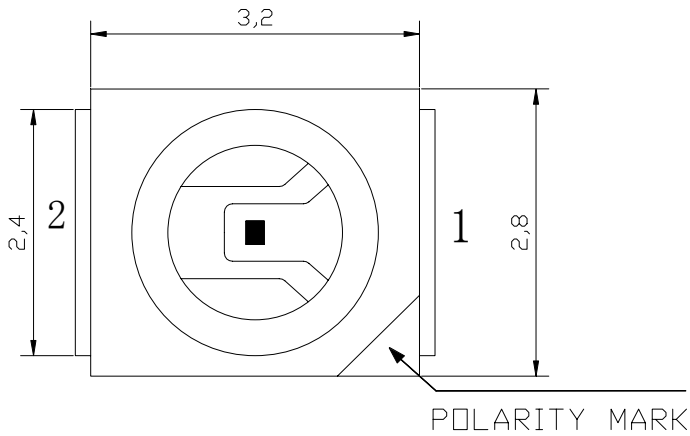

管脚分布图: 2(+) → 1(-)

2. 光电特性 Electrical / Optical characteristics

(1) 最大绝对额定值 Absolute Maximum Ratings (TA=25°C)

项目 Item	符号 Symbol	最大绝对额定值 Absolute Maximum Rating	单位 Unit
正向电流 Forward Current	IF	30	mA
正向脉冲电流 Pulse Forward Current	IFP	100	mA
反向电流 Allowable Reverse Current	IR	85	mA
功率消耗 Power Dissipation	PD	105	mW
工作温度 Operating Temperature	Topr	-40 ~ +110	°C
贮藏温度 Storage Temperature	Tstg	-40 ~ +110	°C
芯片温度 Dice Temperature	Tj	125	°C
焊接温度 Soldering Temperature	Tsld	Reflow Soldering : 260°C Hand Soldering : 350°C	for 10sec. for 3sec.

1/10周期, 0.1 msec脉宽

IFP Conditions : 1/10 Duty Cycle, 0.1 msec Pulse Width.

(2) 原始光电参数 Initial Electrical/Optical Characteristics (TA=25° C)

符号 Symbol	项目 Item	单位 Units	最小值 Min.	规格值 Typ.	最大值 Max.	测试条件 Test Conditions
VF	正向电压 Forward Voltage	V	1.8	-	2.3	IF=20mA
IR	反向电流 Reverse Current	uA	-	-	10	VR=5V
-	发光角度 Viewing Angle		-	120°	-	IF=20mA
Iv	发光强度 Luminous Intensity	Mcd	170		220	IF=20mA
λD	主波长 Dominate Wavelength	Nm	620		630	IF=20mA

(3) 发光强度范围 Luminous Intensity Ranking (TA=25° C)

项目 Item	符号 Symbol	测试条件 Test Conditions	最小值 Min.	最大值 Max.	单位 Units
发光强度 Luminous Intensity	Rank G	IF=20mA	150	180	Mcd
	Rank H	IF=20mA	180	210	Mcd
	Rank M	IF=20mA	420	500	Mcd
	Rank N	IF=20mA	500	600	Mcd

允许误差± 10%

Luminous Intensity Measurement allowance is ± 10%.

(4) 颜色范围 Color Ranking (TA=25° C)

项目 Item	符号 Symbol	测试条件 Test Conditions	最小值 Min.	最大值 Max.	单位 Units
主波长 Dominate Wavelength	Rank 2	IF=20mA	620	625	Nm
	Rank 3	IF=20mA	625	630	Nm

允许误差± 0.01

Color Coordinates Measurement allowance is ± 0.01.

3.特性曲线 Characteristic curve

