



THE NETHERLANDS
(N E D E R L A N D)



COMMUNICATION

Concerning ⁽¹⁾:

- approval granted
- ~~approval extended~~
- ~~approval refused~~
- ~~approval withdrawn~~
- ~~production definitely discontinued~~

of a type of pneumatic tyre for motor vehicles pursuant to Regulation number 54.

Approval number: E4-54R-0017541

Extension number: 00

Approval mark:



0017541

1. Manufacturer's name or trade mark(s) on the tyre type : AUSTONE; CHENGSHAN; FORTUNE; KINETIC
2. Tyre type designation by the manufacturer : AT46; CST46; AT68; CST68; XTL846
3. Manufacturer's name and address : Cooper Chengshan (Shandong) Tire Co., Ltd
No.98, Nanshan North Road,
264300 Rongcheng, Shandong Province,
P.R.China
4. If applicable name and address of manufacturer's representative : not applicable
5. Summarized description
 - 5.1. Tyre size designation : 315/80R22.5
 - 5.2. Category of use : normal/special/snow
 - 5.3. Structure : diagonal(bias-ply)/radial
 - 5.4. Speed category symbol
 - 5.4.1. nominal : M
 - 5.4.2. additional (if applicable) : ---
 - 5.5. Load-Capacity Index

5.5.1. Corresponding to nominal speed	: single 154	twinned (dual)	150
5.5.2. Corresponding to additional speed	: single ---	twinned (dual)	---

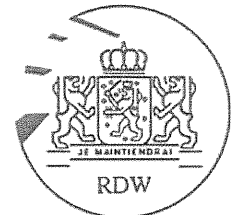

6. Technical Service and, where applicable, test laboratory approved for purposes of approval or of verification of conformity : TÜV Kraftfahrt GmbH
TÜV Rheinland Group
Technologiezentrum Verkehrssicherheit
Typprüfstelle Fahrzeuge/Fahrzeugteile
Am Grauen Stein
D-51105 Köln (Poll)
7. Date of report issued by that service : September 18, 2006
8. Number of report issued by that service : 87-R54-1440/06
9. Reason(s) for extension (if applicable) : not applicable
10. Any remarks : ---
11. Place : Zoetermeer
12. Date : 24-Oct-2006
13. Signature :

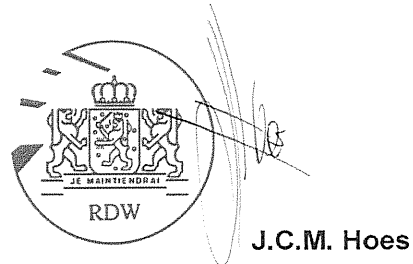

14. Annexed to this communication is a list of documents in the approval file deposited at the administrative service having delivered the approval and which can be obtained upon request.
- Application form, relating to ECE approval for a pneumatic tyre pursuant to Regulation number 54.
 - The drawing of the tyre's side walls, tread and dimensioned cross-section.
 - The test report as mentioned in item 8

⁽¹⁾ Strike out what does not apply

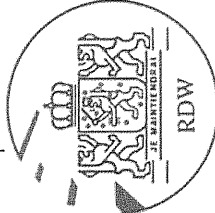
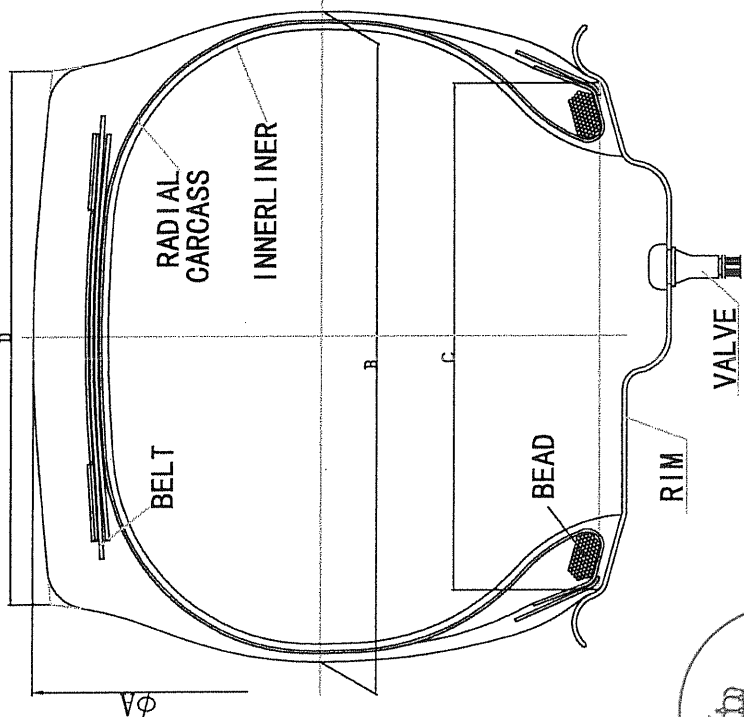

TREAD PATTERNS
 REFER TO ATTACHMENT NO. 0609-18
 BRAND NAME (CHENGSHAN, AUSTONE, FORTUNE, KINETIC)

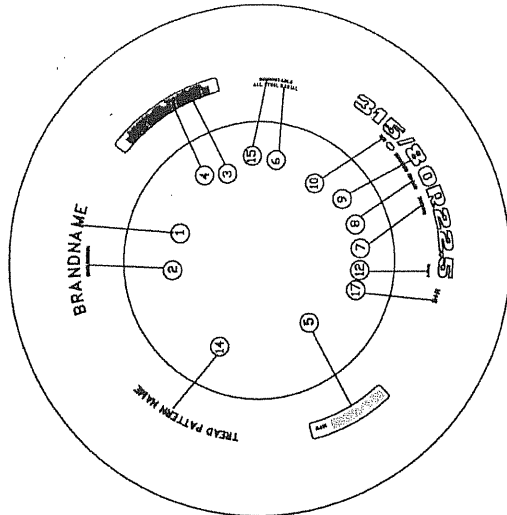
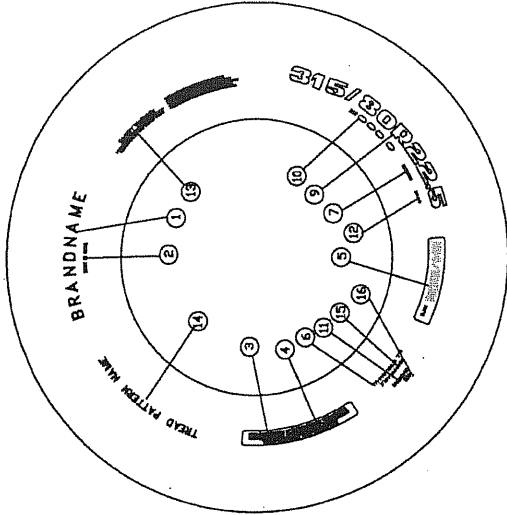

LOWER MOLD

UPPER MOLD

	LOWER MOLD	UPPER MOLD
1	REFER TO ATTACHMENT NO.0609-18(BRAND NAME:CHENGSHAN,AUSTONE,FORTUNE,KINETIC)	REFER TO ATTACHMENT NO.0609-18(BRAND NAME:CHENGSHAN,AUSTONE,FORTUNE,KINETIC)
2	MADE IN CHINA	MADE IN CHINA
3	PLIES: SIDEWALL: 1 STEEL TREAD: 1 STEEL+3 STEEL	PLIES: SIDEWALL: 1 STEEL TREAD: 1 STEEL+3 STEEL
4	MAX.LOAD SINGLE3750kg(8260LBS) AT 825kPa(120PSI)COLD	MAX.LOAD SINGLE3750kg(8260LBS) AT 825kPa(120PSI)COLD
5	MAX.LOAD DUAL 3350kg (7380LBS)AT 825kPa(120PSI)COLD	MAX.LOAD DUAL 3350kg (7380LBS)AT 825kPa(120PSI)COLD
6	154/150M	154/150M
7	ALL STEEL RADIAL	ALL STEEL RADIAL
8	TUBELESS	TUBELESS
9	315/80R22.5	STANDARD RIM 9.00
10	DOT APPROVAL MARK & APPROVAL No.& ***** (Dele. Code)	315/80R22.5
11	©0017541	DOT APPROVAL MARK & APPROVAL No.
12	***** (Mold No.)	***** (Mold No.)
13	<p>SAFETY WARNING: SERIOUS INJURY MAY RESULT FROM: * TYRE FAILURE DUE TO UNDERINFLATION/OVERLOADING --FOLLOE OWNER'S MANUAL OR TYRE PLACARD IN VEHICLE. *EXPLOSION OF TYRE/RIM ASSEMBLY DUE TO IMPROPER MOUNTING --USE SAFETY CAGE AND CLIP ON EXTENSION OF AIR HOSE --ONLY SPECIALLY TRAINED PERSONS SHOULD MOUNT TYRES.</p>	
14	REFER TO ATTACHMENT NO.0609-18(BRAND NAME:CHENGSHAN,AUSTONE,FORTUNE,KINETIC)	REFER TO ATTACHMENT NO.0609-18(BRAND NAME:CHENGSHAN,AUSTONE,FORTUNE,KINETIC)
15	REGROOVABLE	REGROOVABLE
16	1033	
17		M+S

315/80R22.5	154/150	M	TL	1076	312	228.6	232
TYRE SIZE	LOAD INDEX	SPEED SYMBOL	TYPE	A (mm)	B (mm)	C (mm)	D (mm)

DRAWN BY *崔建文* CHECKED BY *20/8/18* APPROVED BY *[Signature]* COOPER CHENGSHAN (SHANDONG) TIRE CO., LTD

ATTACHMENT NO. 0609-18

TIRE SIZE 315/80R22.5 154/150M

0017541

BRANDNAME

AUSTONE

TREAD PATTERN NAME

AT46

AT68

CHENGSHAN

CST46

CST68

FORTUNE

CST46

CST68

KINETIC

XTL846

TREAD PATTERNS

