

THE NETHERLANDS
(N E D E R L A N D)



COMMUNICATION

Concerning ⁽¹⁾:

- approval granted
 - ~~approval extended~~
 - ~~approval refused~~
 - ~~approval withdrawn~~
 - ~~production definitely discontinued~~
- of a type of pneumatic tyre for motor vehicles pursuant to Regulation number 54.

Approval number: E4-54R-0017542

Extension number: 00

Approval mark:



0017542

- | | | |
|--------|---|--|
| 1. | Manufacturer's name or trade mark(s) on the tyre type : | AUSTONE; CHENGSHAN; FORTUNE; KINETIC; PACE |
| 2. | Tyre type designation by the manufacturer : | AT118; CST118; XTR556; AT56; CST56; PM56; PM68; PM46 |
| 3. | Manufacturer's name and address : | Cooper Chengshan (Shandong) Tire Co., Ltd
No.98, Nanshan North Road,
264300 Rongcheng, Shandong Province,
P.R.China |
| 4. | If applicable name and address of manufacturer's representative : | not applicable |
| 5. | Summarized description | |
| 5.1. | Tyre size designation : | 315/80R22.5 |
| 5.2. | Category of use : | normal/special/snow |
| 5.3. | Structure : | diagonal(bias ply)/radial |
| 5.4. | Speed category symbol | |
| 5.4.1. | nominal : | M |
| 5.4.2. | additional (if applicable) : | --- |
| 5.5. | Load-Capacity Index | |
| 5.5.1. | Corresponding to nominal speed : | single 154 twinned (dual) 150 |
| 5.5.2. | Corresponding to additional speed : | single --- twinned (dual) --- |



6. Technical Service and, where applicable, test laboratory approved for purposes of approval or of verification of conformity : TÜV Kraftfahrt GmbH
TÜV Rheinland Group
Technologiezentrum Verkehrssicherheit
Typprüfstelle Fahrzeuge/Fahrzeugteile
Am Grauen Stein
D-51105 Köln (Poll)
7. Date of report issued by that service : September 18, 2006
8. Number of report issued by that service : 87-R54-1441/06
9. Reason(s) for extension (if applicable) : not applicable
10. Any remarks : ---
11. Place : Zoetermeer
12. Date : 24-Oct-2006
13. Signature :

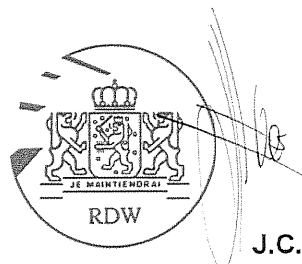

J.C.M. Hoes

14. Annexed to this communication is a list of documents in the approval file deposited at the administrative service having delivered the approval and which can be obtained upon request.
- Application form, relating to ECE approval for a pneumatic tyre pursuant to Regulation number 54.
 - The drawing of the tyre's side walls, tread and dimensioned cross-section.
 - The test report as mentioned in item 8

⁽¹⁾ Strike out what does not apply

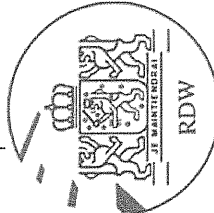
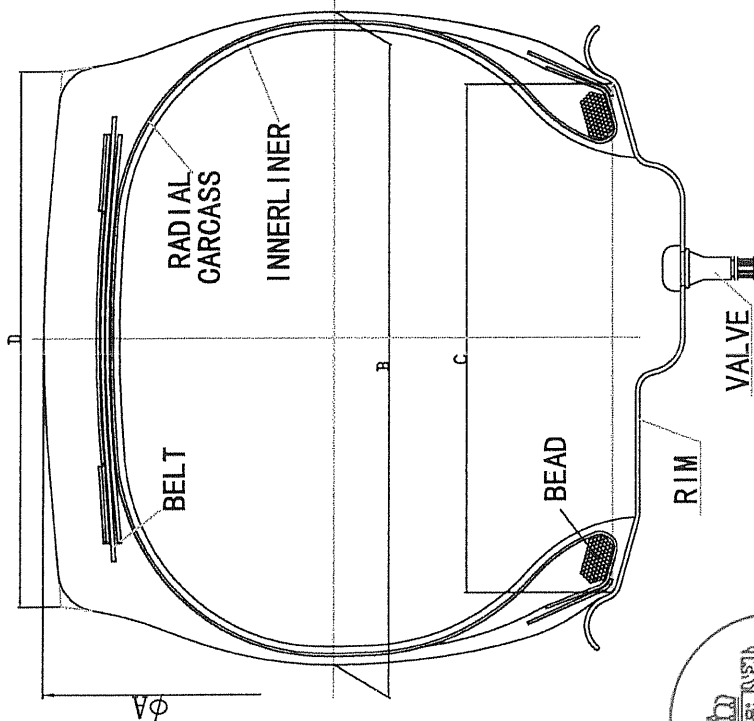

TREAD PATTERNS

REFER TO ATTACHMENT NO. 0609-19

BRAND NAME (CHENGSHAN, AUSTONE, FORTUNE, KINETIC, PAGE)

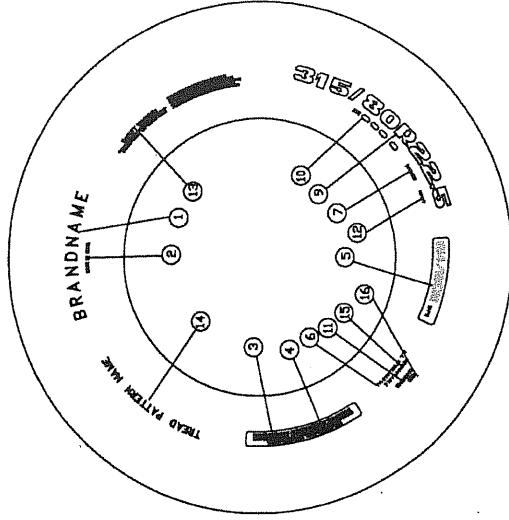

LOWER MOLD

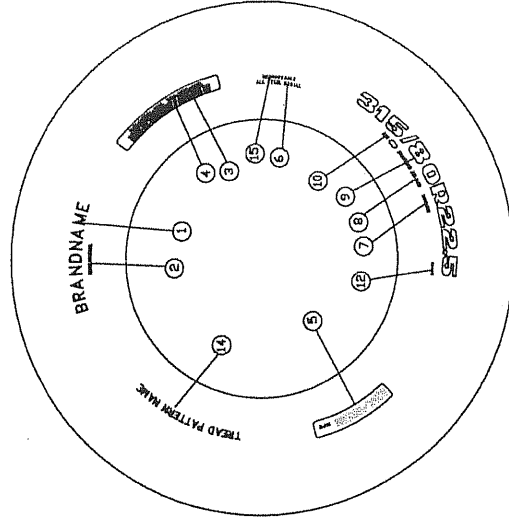

UPPER MOLD

LOWER MOLD		UPPER MOLD	
1	REFER TO ATTACHMENT NO.0609-19(BRAND NAME:CHENGSHAN,AUSTONE,FORTUNE,KINETIC,PAGE)	1	REFER TO ATTACHMENT NO.0609-19(BRAND NAME:CHENGSHAN,AUSTONE,FORTUNE,KINETIC,PAGE)
2	MADE IN CHINA	2	MADE IN CHINA
3	PLIES: SIDEWALL: 1 STEEL TREAD: 1 STEEL+3 STEEL	3	PLIES: SIDEWALL: 1 STEEL TREAD: 1 STEEL+3 STEEL
4	MAX.LOAD SINGLE3750kg(8260LBS) AT 825kPa(120PSI)COLD	4	MAX.LOAD SINGLE3750kg(8260LBS) AT 825kPa(120PSI)COLD
5	MAX.LOAD DUAL 3350kg (7380LBS)AT 825kPa(120PSI)COLD	5	MAX.LOAD DUAL 3350kg (7380LBS)AT 825kPa(120PSI)COLD
6	154/150M	6	154/150M
7	ALL STEEL RADIAL	7	ALL STEEL RADIAL
8	TUBELESS	8	TUBELESS
9	315/80R22.5	9	STANDARD RIM 9.00
10	DOT APPROVAL MARK & APPROVAL No.& ****(****---Date Code)	10	315/80R22.5
11	©0017542	11	DOT APPROVAL MARK & APPROVAL No.
12	*****-*** (Mold No.)	12	*****-*** (Mold No.)
13	<p>SAFETY WARNING:</p> <p>SERIOUS INJURY MAY RESULT FROM:</p> <ul style="list-style-type: none"> * TYRE FAILURE DUE TO UNDERINFLATION/OVERLOADING --FOLLOW OWNER'S MANUAL OR TYRE PLACARD IN VEHICLE. *EXPLOSION OF TYRE/RIM ASSEMBLY DUE TO IMPROPER MOUNTING --USE SAFETY CAGE AND CLIP ON EXTENSION OF AIR HOSE --ONLY SPECIALLY TRAINED PERSONS SHOULD MOUNT TYRES. 		
14	REFER TO ATTACHMENT NO.0609-19(BRAND NAME:CHENGSHAN,AUSTONE,FORTUNE,KINETIC,PAGE)	14	REFER TO ATTACHMENT NO.0609-19(BRAND NAME:CHENGSHAN,AUSTONE,FORTUNE,KINETIC,PAGE)
15	REGROOVABLE	15	REGROOVABLE
16	1033	16	1033

315/80R22.5	154/150	M	TL	1076	312	228.6	232
TYRE SIZE	LOAD INDEX	SPEED SYMBOL	TYPE	A (mm)	B (mm)	C (mm)	D (mm)

DRAWN BY

CHECKED BY

APPROVED BY

COOPER CHENGSHAN (SHANDONG) TIRE CO., LTD

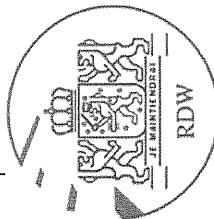
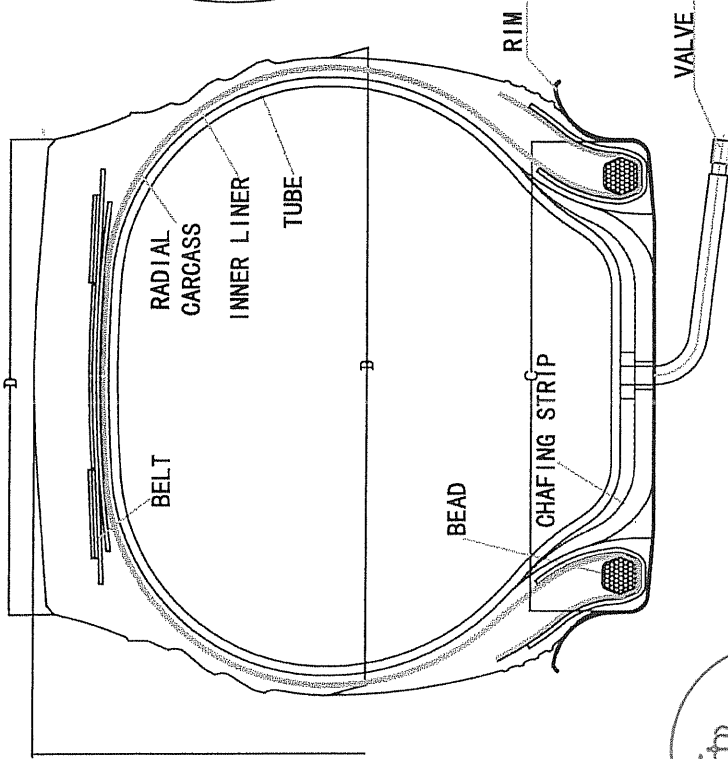

TREAD PATTERNS
REFER TO ATTACHMENT NO. 0609-19
(BRAND NAME: CHENGSHAN, AUSTONE, FORTUNE)

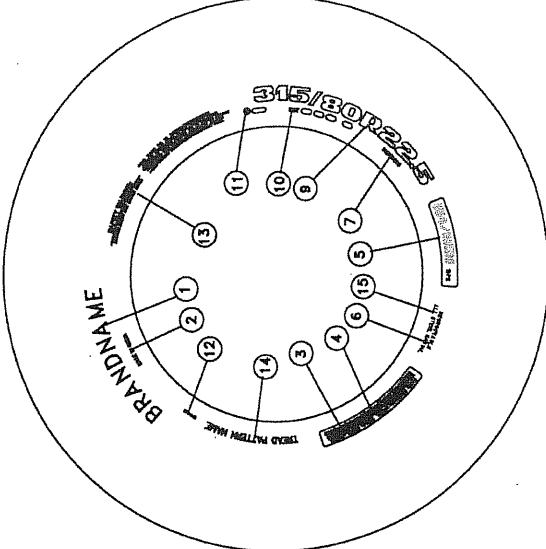

LOWER MOLD

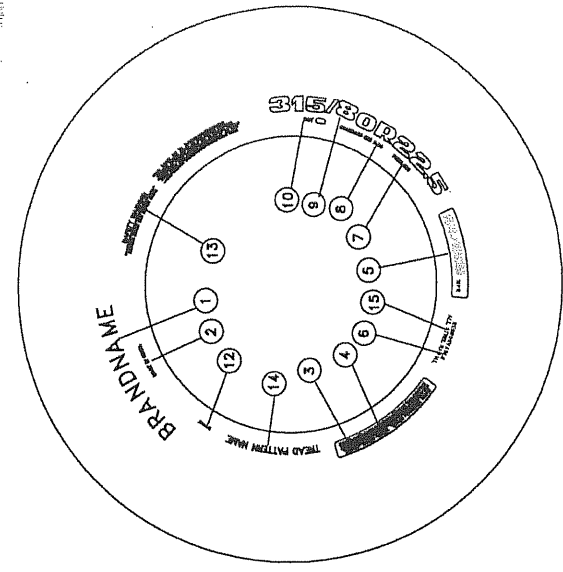

UPPER MOLD

LOWER MOLD		UPPER MOLD	
1	REFER TO ATTACHMENT NO.0609-19(BRAND NAME:CHENGSHAN,AUSTONE,FORTUNE) MADE IN CHINA	1	REFER TO ATTACHMENT NO.0609-19(BRAND NAME:CHENGSHAN,AUSTONE,FORTUNE) MADE IN CHINA
2	PLIES: SIDEWALL: 1 STEEL TREAD: 1 STEEL+3 STEEL	2	PLIES: SIDEWALL: 1 STEEL TREAD: 1 STEEL+3 STEEL
3	MAX.LOAD SINGLE:3750kg(8260LBS) AT 825kPa(120PSI)COLD	3	MAX.LOAD SINGLE:3750kg(8260LBS) AT 825kPa(120PSI)COLD
4	MAX.LOAD DUAL 3350kg (7380LBS)AT 825kPa(120PSI)COLD	4	MAX.LOAD DUAL 3350kg (7380LBS)AT 825kPa(120PSI)COLD
5	154/150M	5	154/150M
6	REGROOVABLE	6	REGROOVABLE
7	TUBELESS	7	TUBELESS
8	315/80R22.5	8	315/80R22.5
9	DOT APPROVAL MARK & APPROVAL No.& ****(****)----Date Code	9	DOT APPROVAL MARK & APPROVAL No. & APPROVAL No.
10	0017542	10	0017542
11	***** (Mold No.)	11	***** (Mold No.)
12	SERIOUS INJURY MAY RESULT FROM: * TYRE FAILURE DUE TO UNDERINFLATION/OVERLOADING --FOLLOE OWNER'S MANUAL OR TYRE PLACARD IN VEHICLE *EXPLOSION OF TYRE/RIM ASSEMBLY DUE TO IMPROPER MOUNTING --USE SAFETY CAGE AND CLIP ON EXTENSION OF AIR HOSE --ONLY SPECIALLY TRAINED PERSONS SHOULD MOUNT TYRES.	12	SERIOUS INJURY MAY RESULT FROM: * TYRE FAILURE DUE TO UNDERINFLATION/OVERLOADING --FOLLOE OWNER'S MANUAL OR TYRE PLACARD IN VEHICLE *EXPLOSION OF TYRE/RIM ASSEMBLY DUE TO IMPROPER MOUNTING --USE SAFETY CAGE AND CLIP ON EXTENSION OF AIR HOSE --ONLY SPECIALLY TRAINED PERSONS SHOULD MOUNT TYRES.
13	315/80R22.5	13	315/80R22.5
14	ALL STEEL RADIAL	14	ALL STEEL RADIAL
15	ALL STEEL RADIAL	15	ALL STEEL RADIAL

315/80R22.5	154/150	M	TL	1076	312	228.6	232
TYRE SIZE	LOAD INDEX	SPEED SYMBOL	TYPE	A (mm)	B (mm)	C (mm)	D (mm)

DRAWN BY 崔建义 CHECKED BY [Signature] APPROVED BY [Signature] COOPER CHENGSHAN (SHANDONG) TIRE CO., LTD

ATTACHMENT NO. 0609-19

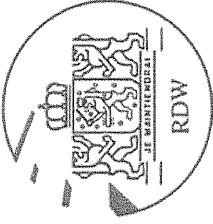

TREAD PATTERNS

TIRE SIZE 315/80R22.5 154/150M

0017542

BRANDNAME

AUSTONE

CHENGSHAN

FORTUNE

KINETIC

PAGE

TREAD PATTERN NAME

AT56

AT118

CST56

CST118

CST56

CST118

XTR556

PM56

PM68

PM46

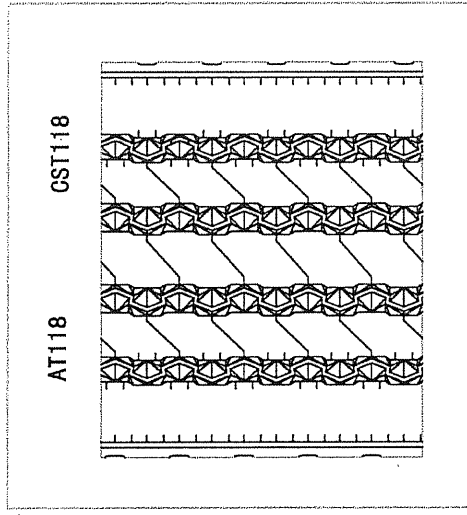

AT118

CST118

PM 46

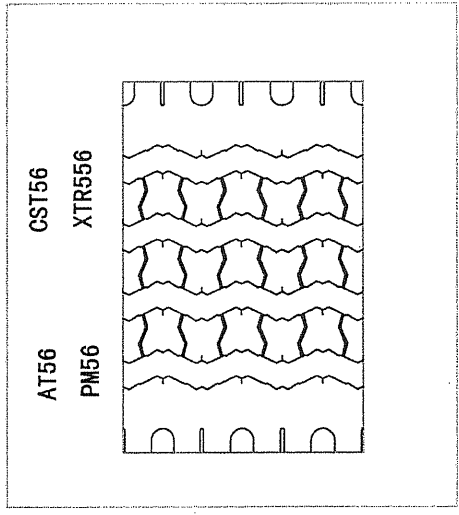

AT56

PM56

CST56

XTR556

PM68