



Giant Alarm System Co., Ltd

Tel: 86-595-2249 9516 Fax: 86-595-2249 2516







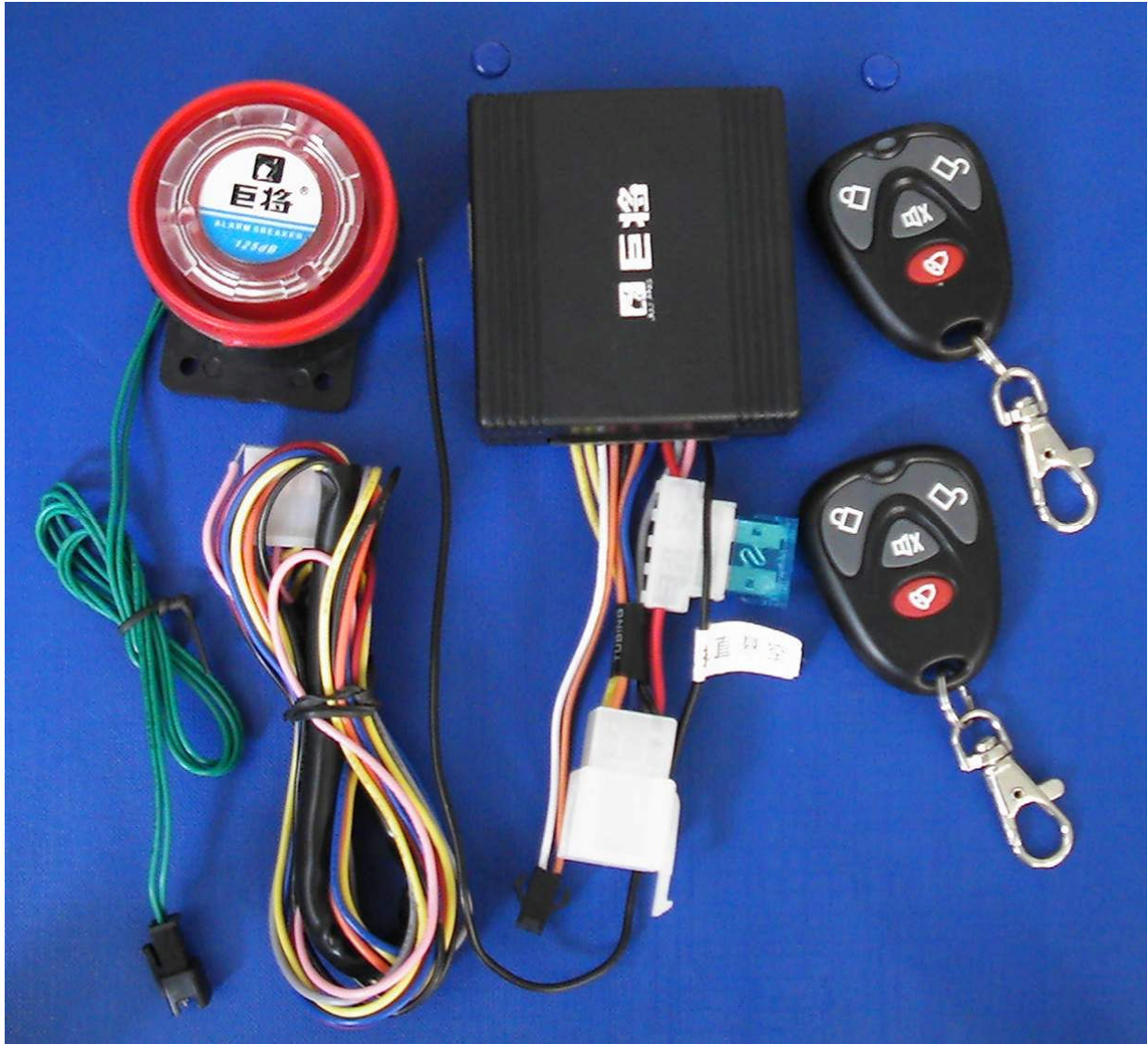









Web: [www.jujiang.net](http://www.jujiang.net) or [www.globalsources.com/giant.co](http://www.globalsources.com/giant.co) or [www.jujiang.en.alibaba.com](http://www.jujiang.en.alibaba.com)

## Motorcycle Alarm System (JJ-MB-02-2)

### User's Manual





Function Key	Operation Instruction and Functions
Arm 	I. Press  to arm the system. (lights flash one time, siren sounds one time then enter the arming state in 3 seconds.)  II. When robbed in driving, you can press  to stop the engine(the distance between you and the motorcycle should be within 100 meters), then siren will sound loudly, lights keep flashing to frighten the robber.
Disarm 	I. Press  to disarm the system/stop the engine.
Siren 	I. In driving, press  , the light flashes and the siren sounds for 5S to tell the front vehicle that you would overtake it.  II. When you're in emergency, press  , siren will sound loudly and the lights flash 15S to warn the villainous.  III. To find out your motorcycle in a large parking lot or in the dark, you may press  , then the siren will sound 2S and the lights keep flashing to indicate its position.
Start 	I. In arming state, twice press  to start the warming function; if it doesn't work, repeat the above operation.  II. In arming state, press  , if the engine doesn't work in 3S, the siren will sound and the system returns to the arming state.
Adjust Sensibility  + 	Press  +  at the same time, the siren sounds and the main unit goes into the four-grade shocking sensibility adjusting----the siren sound one time the sensibility will be in first grade(lowest)...the siren sounds four times the sensibility will be in four grades(highest).



### Installing Instruction

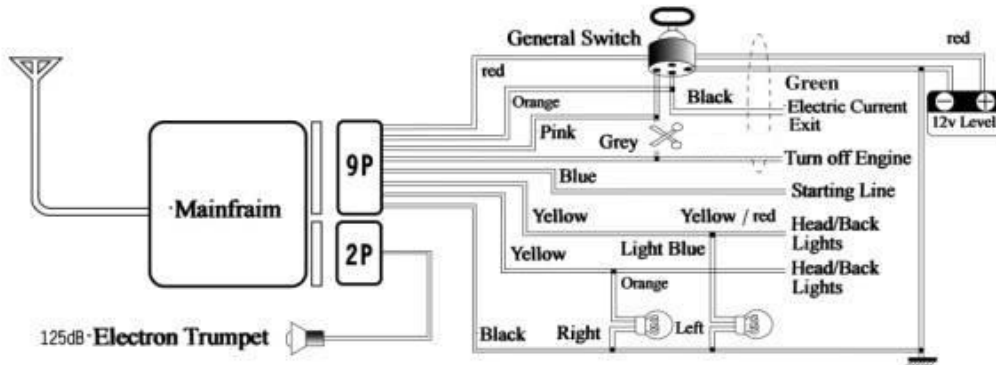

### Quality Guarantee:

- We will guarantee refundable\returnable/repairable in 6 months from the day you purchase our product.
- We won't guarantee repairable if you open the mainframe.
- Siren ruin or battery loss won't be guaranteed.

### Notice:

- Remote control is exquisite; it can't be roughly thrown or dipped into the water.
- Do not press start button on the motorcycle and start button on the remote at the same time, otherwise the fuse will burn out.
- Please change brake light when it's ruined, and don't press start button on the remote.
- Please use new battery when the remote distance shortens and the LED becomes dark.