

Mil-Spec Night Vision Goggles Gen 3,  
SHD-3™ & XD-4™ SKU# TY-N16

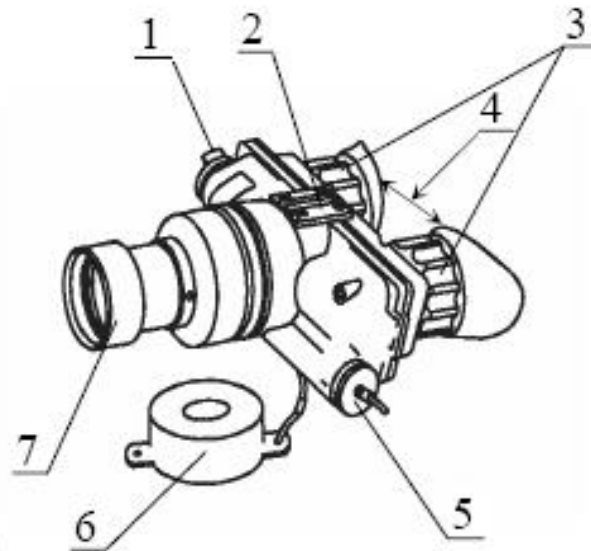

Directions to use

Mil-Spec Night Vision Goggles Gen 3,  
SHD-3™ & XD-4™ SKU# TY-N16



1. On-Off, I/R Switch
2. Mounting socket
3. Eyepiece adjustments
4. Eyepieces
5. Battery house cover
6. Objective lens cover
7. Objective lens focus

# OVERVIEW

The TY-N16 type night vision is observational optical-electronic Binoculars /goggles, intended for examining objects and orientation at nighttime or dark conditions. The unit utilizes a HyperGen technology image intensifier tube, which amplifies available moonlight, starlight or man-made light. The device was designed to be easy to use, and provide many years of operation.

**Some of the typical activities where TY-N16 will be useful:**

- Law enforcement
- Wildlife observation
- Security
- Search and rescue
- Hunting
- Photography (Dark room operation)

## Features

- Waterproof construction
- Built-in infrared illuminator
- Automatic brightness control
- Equipped with momentary or continuous IR Switch
- Automatic high-light cutoff
- Multifunctional: Hand-held, head-mounted, helmet-mounted, or tripod mounted
- High resolution 64 lp/mm (Typical), high gain, high signal-to noise ratio (min 19 ) and high photo response (min:600-750 uA/lm) in visible and near infrared.

## 1 GENERAL INFORMATION

1.1 The night vision goggles Omega TY-N16 with built on HyperGen technology image intensifier, infrared illuminator (IR) and bright light sources protection, are intended for observation, recognition at areas, vehicles drive (with objective lens 1<sup>x</sup>) at dark time, performance various operations in dark rooms, cavities e. t. c.

1.2 TY-N16 performed on I<sup>2</sup> with photocathode diameter 18mm, that provides angular field of view 40° with objective lens 1x.

1.3 TY-N16 has indicator of IR illuminator switch on and battery discharge indication that introduced into both oculars as red light spot. Continuous spot light, discharge IR illuminator switch on, indicates of battery (voltage supply decrease from 1.9 to 2.1 V).

1.4 To convenience the user, TY-N16 is equipped by IR illuminator activated by non-fixed button depression or fixed by switch.

Individual number \_\_\_\_\_

Date manufacture \_\_\_\_\_

## 2 TECHNICAL DATA

2.1 Parameters at delivery must be in accordance with ones, listed in table 1.

Table 1

Designation parameter	Signification parameter
1. Identification range of body figure, m, no less	220
2. Image tube	18mm HyperGen
3. Resolution, lp/mm	55-64
4. Magnification, x	1 x
5. Angular field of view, degree	$40 \pm 2$
6. Objective lens system	F1.1 f=25
7. Lens focusing range, m	From 0,25 to $\infty$
8. Diopter adjustment	-6 ~+5
9. Interpupillary distance ,mm	57-72
10. Eye relief ,mm	15
11. Battery life with / without of IR, h, no less	40/80
12. Readiness time NVGI to operation, s, no more	4
13. Voltage supply, V	3V 2pcs standard AA batteries
14. Battery discharge indicator activation threshold, V	From 1,9 to 2,1
15, IR illuminator	Yes (built-in)
16. Difference of left and right channel magnification, %, no more	$1 \pm 5\%$

## 2.2 Ambient conditions:

-sinusoidal vibration:

Frequency range.....20~30 Hz

-impact resistance.....50m/s<sup>2</sup> (5g);

-operation temperature, °C.....-40~+40;

-relative humidity at 25°C..... 98%;

-watertightnes..... 0.5m (30min.).

## 2.3 TY-N16 outline dimensions and mass

Outline dimensions and mass of TY-N16 (with supply elements) depended on modification must be in accordance with values, listed in table 2.

Designation dimensions	Signification parameter
Length, mm, no more	187
Width mm, no more	132
Height mm, no more	58
TY-N16 night vision goggles (including batteries), kg, no more	0, 50
Head mount, kg	0, 17
Soft case, kg	0, 25

## 3 COMPLETIONS

3.1 The main delivery completion must be in accordance with value, indicated table 3.

Table 3

Designation	Unit
1. Hard case	1
2. Soft case	1
3. Night vision goggles TY-N16	1
4. Warranty certification	1
5. Cleaning cloth	1
6. Objective lens cover	1
7. Operators manual instruction	1
7. Data sheet	
8. Batteries (AA)	1
9. Head mount	1
10. Neck strap	1



### 3.2 The HyperGen technology image intensifier tube main parameters

Image Intensifier Type	HyperGen
Photocathode operating diameter, mm	18
Photocathode type	S-25
Photocathode sensitivity $\mu A/ lm \text{ min}$	600
Radiant sensitivity at $\lambda =850 \text{ nm}$ , $\text{mA/W}$ , min	40
Resolution , $\text{lp/mm}$ min	55
Luminous gain at $100\mu\text{lx}$ min	25000
EBI, $\mu\text{lx}$ , max	0. 25
Signal to noise ratio (at $108\mu\text{lx}$ ), min	19
MTTF (Mean time to failure), hours	10000
Halo with 0.35 diam input mm max	1.25
Modulation transfer function	
2.5 $\text{lp/mm}$	0.86
7.5 $\text{lp/mm}$	0.62
15 $\text{lp/mm}$	0.32
Shock acceleration $\text{m/s}^2$ (g)	5000 (500)
Operating temperature , $^{\circ} \text{C}$	-50 to +50

## 4 USE DIRECTIONS

### 4.1 Preparation to operation

**WARNING!** Switch to “ON” at light must be

Only with cup placed on the objective.

.1 Preparation for use is performed abnormal light level.  
As supply source is recommended element of Duracell (USA).

Turn switch to “OFF” position.

Remove battery cap, that is marked ( “-” ) (minus). Insert two elements.  
Ensure, that polarity is correct, replace battery cap.

Ensure that objective lens is covered by lens cap.

Install head harness without the goggles to the head, latch button on the chin, tighten the straps at back of the head to close position.

Release latch on the chin and remove the head harness.

Install the goggles to the head harness ( “swallow tail” must be placed to the guides of the head harness) and secure it by fixing nut. Turn the goggles to inoperative position (press the head harness lever). In that position install the head harness with the goggle to the head.

Press the head harness lever and turn the goggles to operative position. Turn switch to “ON” position. After 1-3 sec. image will appear. Adjust diopter by ocular rings (the best image has the sharpest hexagonal structure of micro channel plate).

Adjust objective focus by objective rings (with cap installed on the objective, sharpness is slight variable).

Adjust head harness straps length to the best comfortable position and optimal viewing conditions. Turn switch to “OFF” position.

Remove head harness assembly with the goggles, release latch on the chin. Remove the goggles from the head harness release fixing nut. Remove supply elements and replace battery cap. Supply elements must be stored apart the goggles. (It should be installed when device is prepared to use).

Put the goggles to the bag, secure it by strap.

Install head harness coupler to unopened position, put the head harness to the bag, and close the bag.

## 4.2 Viewing

Viewing is performed at low light level.

Remove objective lens cap and put it to the bag, fixing by the “adhesive” .

Install the head harness with the goggles, turn the goggles to operative position, turn switch to “ON” position. When goggles are turned on and at bottom of field of view the red indicator blinks, this means, that battery is poor. See table 2. Turn the goggles off and replace the battery.

Adjust the diopter and objective lens focus.

Table 4

Node	Indicator	Means
ON	No lights	The battery are right IR mode is off
ON	Blinks	The battery are poor
IR	Lights	The battery are right IR mode is on
IR	Blinks	The battery are poor IR mode is on

When viewing at extreme darkness (at basements, caves and low light level of stars, moon e.t.c.) turn switch to “IR” position (Infrared illuminator). In this case, at button of field of view the red indicator appears, that lights continuously, this means, that IR mode is activated. After the operation turn switch to “OFF” position. Remove head harness with the goggles, remove the goggles, remove supply elements and put the goggles to the bag accordance p.4.1.

**WARNING!** The IR source is light that is invisible to the unaided eye for use during conditions of darkness.

## 4.3 Use requirements

4.3.1 TY-N16 use at light time is not allowed.

4.3.2 Direction operated TY-N16 to bright light sources (lamp, welding e.t.c.) is not allowed, because this may lead to their failure.

4.3.3 It is necessary to protect TY-N16 of shocks, moisture, and sudden temperature change.

4.3.4 After TY-N16 use in moisture conditions, it is necessary switch on, dry and wipe.

4.3.5 For optical surfaces cleaning use napkin or absorbent cotton moistened in water.

## **5 MANUFACTURER WARRANTY**

The manufacturer warrants the TY-N16 quality to demands of the specifications if the users do not violate use and storage directions.

Guaranteed use time is 12 months from sale date.

Guaranteed TY-N16 storage time in bag at storage rooms -2 years from manufacture date, and for TY-N16, subjected to reinspection-from reinspection date.

Requirements for reliability for export delivery must be with accordance with conditions of contract of products delivery.

## **6 CONFIRMATION OF THE CERTIFICATION**

The night vision goggles Omega TY-N16 fabrication number \_\_\_\_\_  
Correspond to the specification and are ensured fit to use.

Fabrication date \_\_\_\_\_

Technical inspection division

Representative \_\_\_\_\_

## Yiwu Tianying Optical Instrument Co., Ltd

Company Address: Room 402, 1 Unit, 26 building, Fancun, Yiwu City,

Zhejiang, China

Post Code: 322000

Telephones No.:0086-579-85389306

Fax No.:0086-579-85389305

Mobile Phone: 0086-13515798545

Email: [info@nightvisioncn.com](mailto:info@nightvisioncn.com) / [nightvision@live.cn](mailto:nightvision@live.cn)

web: <http://www.nightvisioncn.com>