

# DMX512 Wireless Transmitter & Receiver

(GN-RF-RX、GN-RF-TR)

Manual

REV 2.3

2010.04.21

DMX512 Wireless Transmitter (GN-WF-TR)

DMX512 Wireless Receiver (GN-RF-RX)



Guangnan Electronics, Ltd

# Contents

|  |          |
|--|----------|
| <b>Chapter I Products .....</b>  | <b>3</b> |
| 1.1 Product Function .....   | 3        |
| 1.2 Product Features.....  | 3        |
| 1.3 Product Diagram .....  | 3        |
| 1.4 Hardware Wiring.....   | 4        |
| Wiring method for input cannon (XLR): .....                                  | 4        |
| Wiring method for output cannon (XLR): .....                                 | 4        |
| Block cable wiring (RJ-45) .....   | 5        |
| DMX512 control connected to lights via DMX512 transmitter/receiver: .....    | 5        |
| <b>Chapter II Usage.....</b>   | <b>6</b> |
| 2.1 DMX512 T/R digital tube display and operation.....                       | 6        |
| Transmission.....  | 6        |
| Reception .....  | 6        |
| 2.2 DMX512 T/R to work normally: .....                                       | 6        |
| Reliable working conditions (wireless DMX512 transmitter and receiver) ..... | 6        |
| Operation steps (wireless DMX512 transmitter and receiver).....              | 7        |
| 1. both are wired up.....  | 7        |
| 2.3 Using DMX512 T/R as DMX512 amplifier or adaptor .....                    | 7        |
| <b>Chapter III Accessories &amp; Specs.....</b>                              | <b>8</b> |
| 3.1 Size & Weight:.....  | 8        |
| 3.2 Product & Accessories: .....   | 8        |
| <b>Chapter IV Troubleshooting &amp; Maintenance.....</b>                     | <b>9</b> |

# Chapter I Products

## 1.1 Product Function

DMX512 wireless transmitter/receiver transmits standard DMX512 protocol data, and can be used in transmissions between DMX controller and lights or among lights. It is a replacement for the long depended twisted pairs, featuring no delay and reliability during transmission. It uses 2.4G globally open ISM frequencies, making it a cost-efficient and yet widely applicable powerful wireless transmitter/receiver.

## 1.2 Product Features

- Up to 252 channels, intermittance 200KHz.
- 39-class adjustable power output from -50dBm to 20dBm, visible communication distance >600m.
- Working with ISM frequencies, no license needed for 2.4-2.4835 GHz.
- Nearly 10 thousand combinations to guarantee no jamming among multiple transmitters/receivers.
- Featuring multiple auto correction methods to guarantee reliable data transmission.
- Easy and stable.
- 4-lane DMX512 output and can also be used as an amplifier or adaptor.
- DMX-512/1990 ISP. 512 loops outputting standard DMX512 signal.
- Small, light, and portable.

## 1.3 Product Diagram

Front:

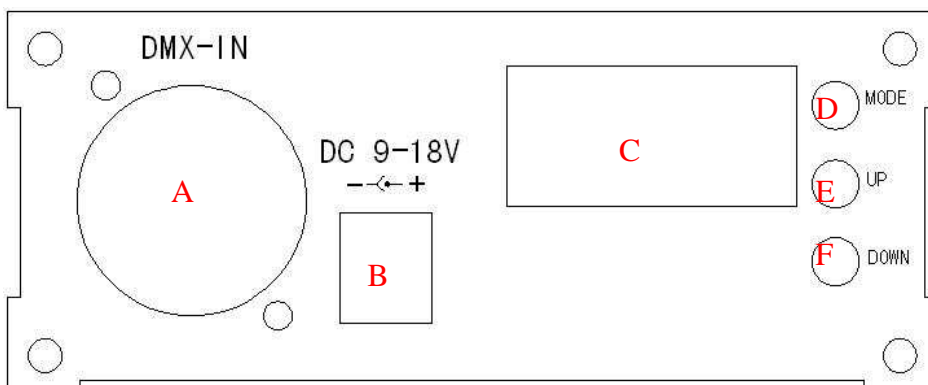

**Back:**

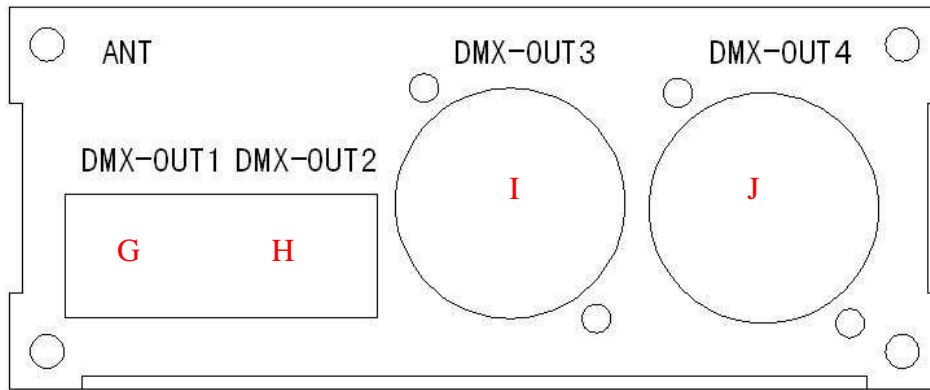

**Notes:**

|   |   |
|---|---|
| A | DMX IN cannon (XLR) DMX512 signal input           |
| B | DC9--18V DC input                                 |
| C | 4-digit numerical tube                            |
| D | MODE button                                       |
| E | UP data + button                                  |
| F | DOWN data - button                                |
| G | DMX-OUT1 block cable (RJ-45) DMX512 signal output |
| H | DMX-OUT2 block cable (RJ-45) DMX512 signal output |
| I | DMX-OUT3 cannon (XLR) DMX512 signal output        |
| J | DMX-OUT4 cannon (XLR) DMX512 signal output        |

## 1.4 Hardware Wiring

### Wiring method for input cannon (XLR):

Notes: universal wiring method

Foot 1: ground line

Foot 2: signal line negative

Foot 3: signal line positive



### Wiring method for output cannon (XLR):

Notes: universal wiring method

Foot 1: ground line

Foot 2: signal line negative

Foot 3: signal line positive

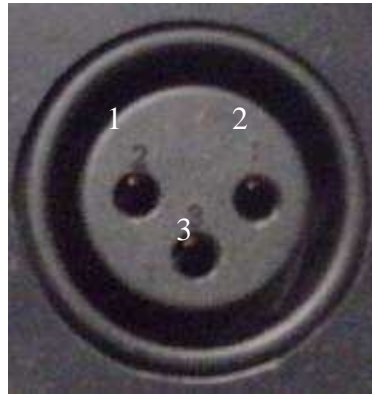

## Block cable wiring (RJ-45)

Notes: RJ-45 wiring method

Foot 1: ground line

Foot 2: signal line negative

Foot 3: signal line positive

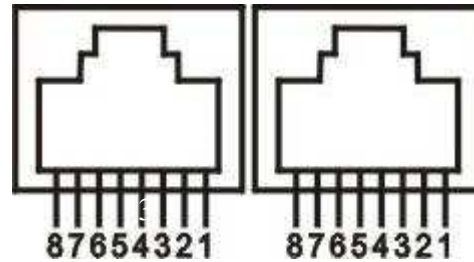

## DMX512 control connected to lights via DMX512 transmitter/receiver:

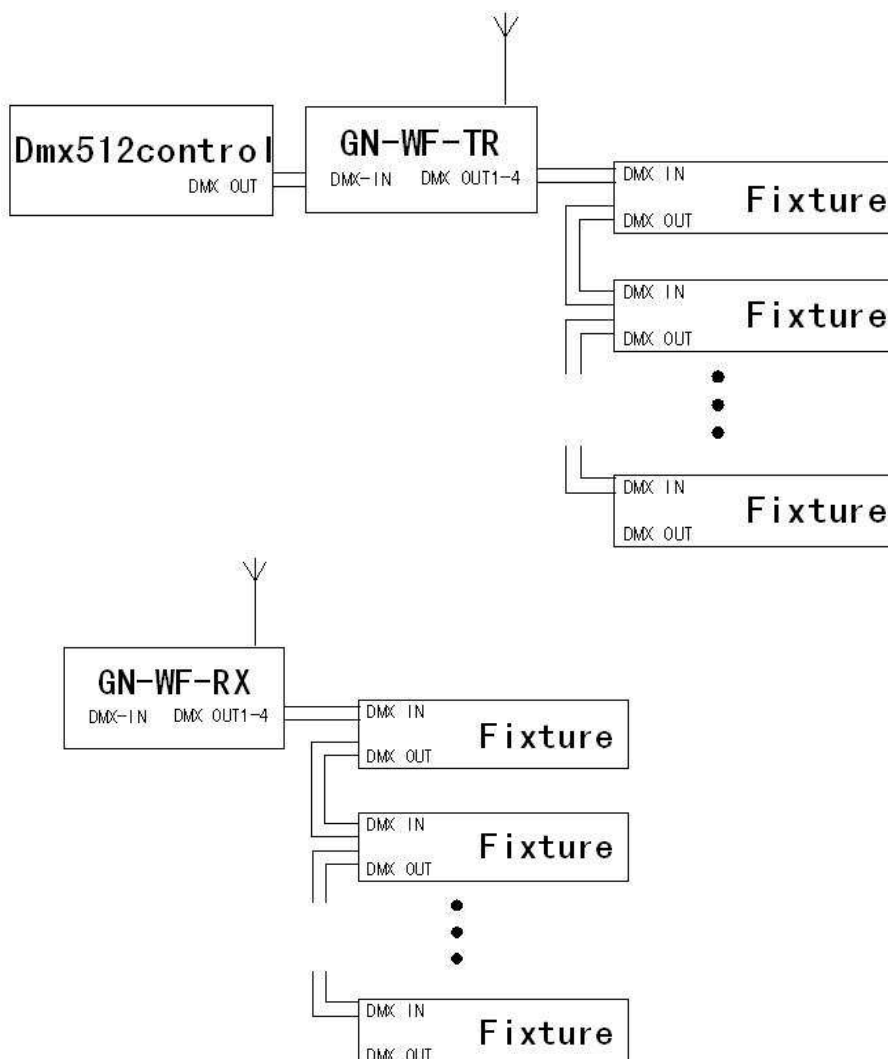

# Chapter II Usage

## 2.1 DMX512 T/R digital tube display and operation

### Transmission

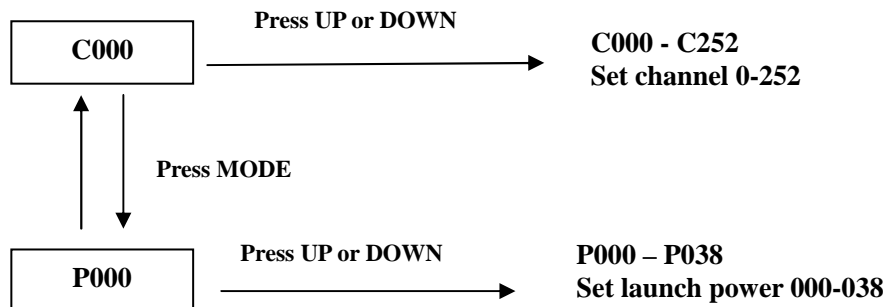

Press and hold MODE >5 sec for:

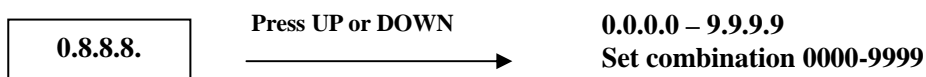

Press MODE to finish combination setting.

### Reception

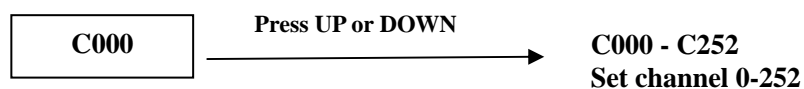

Press and hold MODE >5 sec for:

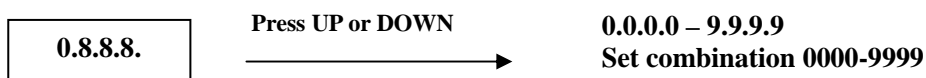

Press MODE to finish combination setting.

## 2.2 DMX512 T/R to work normally:

**Reliable working conditions (wireless DMX512 transmitter and receiver)**

1. Both channels are set accordingly.
2. Both combinations are the same.

3. Appropriate launch power.
4. within defined communication distance.

### **Operation steps (wireless DMX512 transmitter and receiver)**

1. Both are wired up.
2. Observe if the decimal point is on in the transmitter tube.  
On: means channel is busy. Choose another one.  
Off: means channel is available for use.
3. Set proper launch frequency for DMX512 transmitter.
4. hook wireless DMX512 transmitter with DMX512 control, the Decimal point in the tube starts to twinkle.
5. Set the channel and combination of receive the same as transmitter.
6. Check if the decimal point in receiver twinkles  
Twinkle: means signal received, available for use.  
Doesn't twinkle: check working conditions.

**Note:**

**During use, if DMX512 wireless transmitter detects busy channels, it will adjust frequency.**

### **2.3 Using DMX512 T/R as DMX512 amplifier or adaptor**

When wireless DMX512 is used as DMX512 amplifier or adaptor, the launching frequency can be set to minimal to cut power consumption, as shown in diagram above.

When wireless DMX512 is used as DMX512 amplifier or adaptor, if both wired and wireless signals are received, DMX512 outputs wired signal. Wireless signal is invalid.

# Chapter III Accessories & Specs

## 3.1 Size & Weight:

1. 97 X 60 X 40mm
2. Weight: 0.2KG

## 3.2 Product & Accessories:

1. A **DMX512** wireless transmitter or receiver.
2. A PS adaptor.

## Chapter IV Troubleshooting & Maintenance

- 1, Abnormality: tube display not normal after connection to 12V DC.

Troubleshooting: check the 12V DC plug and see if there is 12V DC input. Please use a meter to when checking. If trouble persists, please disconnect PS and contact us.

- 2, Abnormality: tube display works fine, but signal cannot be transmitted or received.

Troubleshooting: check XLR plug, if no problem, contact us.