

FAIRCHILD

PNEUMATIC PRECISION BACK PRESSURE REGULATOR

Model 10BP



FAIRCHILD
INDUSTRIAL PRODUCTS COMPANY

CROSS SECTION

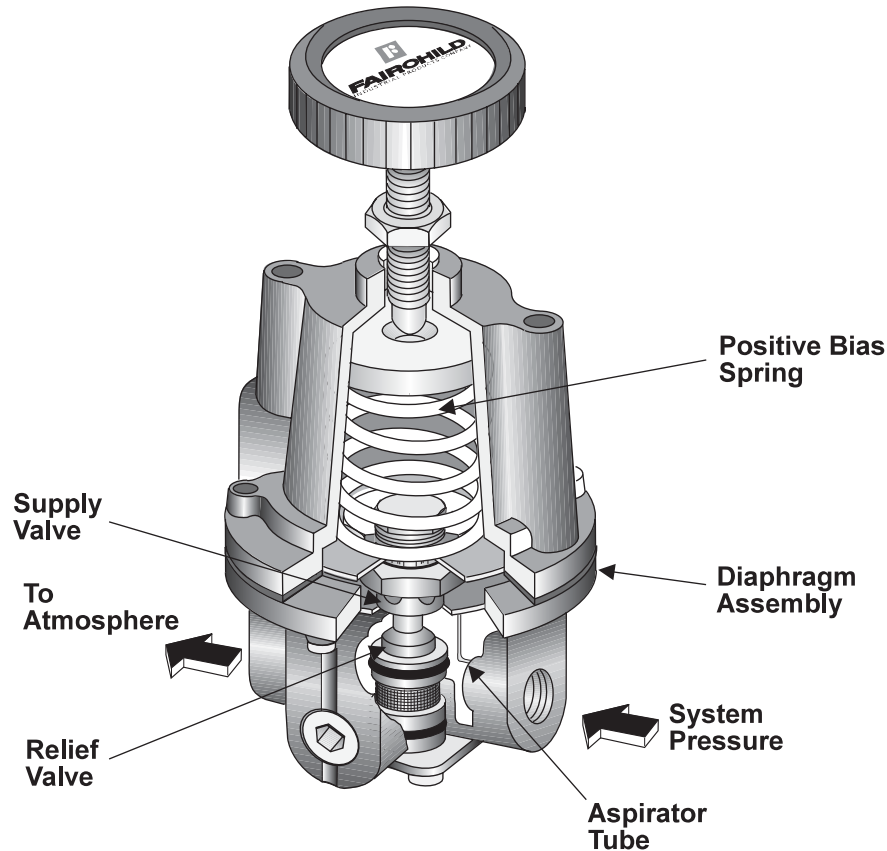

Figure 1. Model 10BP Detail Drawing

GENERAL INFORMATION

The Model 10BP is a high capacity regulator that relieves excess pressure in a pneumatic system.

The Model 10BP provides greater accuracy than relief valves over a narrow pressure range. The Model 10BP is an excellent choice for a wide range of precision applications.

The Model 10BP has the following features:

- Control sensitivity of 1/8" water column allows use in precision applications.
- A separate Control Chamber and Aspirator Tube isolate the diaphragm from the main flow to eliminate hunting and buzzing.
- Unit construction lets you service the Model 10BP without removing it from the line.
- A Mounting Bracket is available.

OPERATING PRINCIPALS

The Model 10BP Regulator uses the force balance principle to open the Relief Valve and vent system pressure when the set point is exceeded.

Downstream pressure is transmitted through the Aspirator Tube to the bottom of the Diaphragm Assembly. When you adjust the range screw for a specific set point, the Positive Bias Spring compresses and exerts a force on the top of the Diaphragm Assembly. As long as the pressure acting on the bottom of the Diaphragm Assembly produces a force less than the spring force acting on the top of the Diaphragm Assembly, the Relief Valve remains closed. When system pressure increases, the force on the bottom of the Diaphragm Assembly increases until it reaches the set point. When system pressure increases beyond the set point, the assembly moves upward, lifting the Relief Valve from its seat and vents the downstream air.

If downstream pressure decreases below the set point, the assembly moves downward closing the Relief Valve. For more information, see Figure 3.

OUTLINE DIMENSIONS

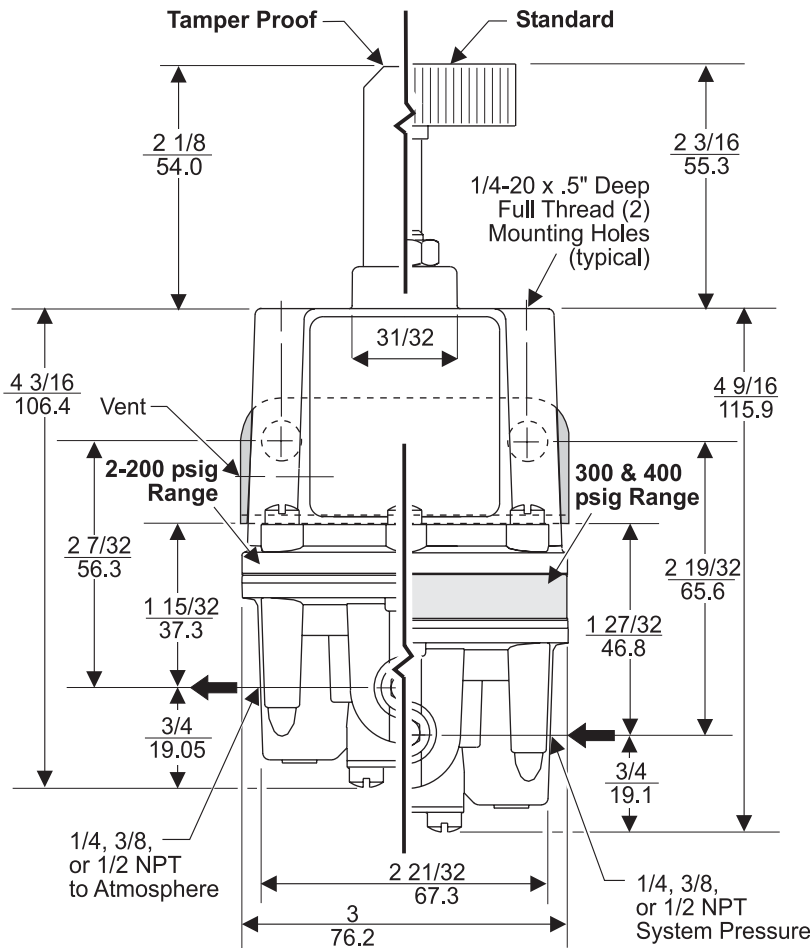

Figure 2. Model 10BP Outline Dimensions

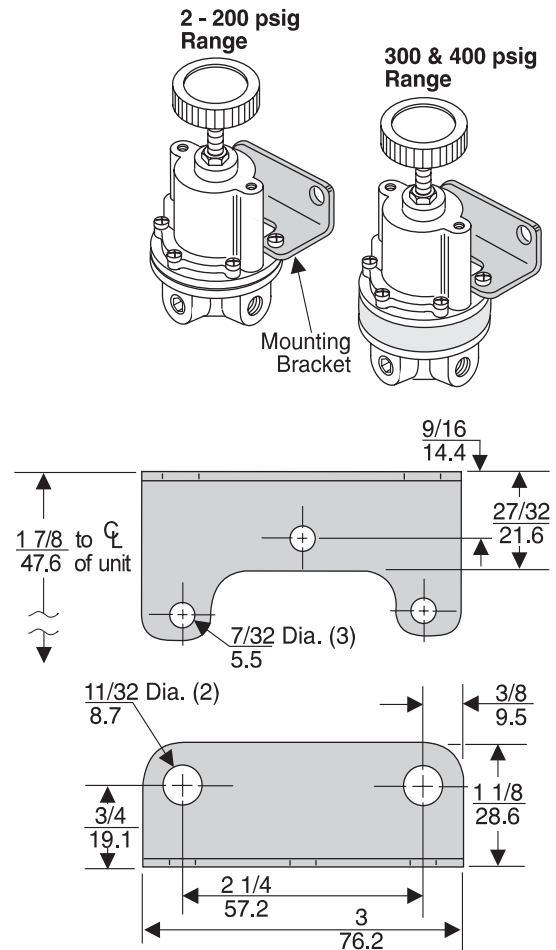

Figure 3. Mounting Bracket EB-09921 (Sold separately)

SPECIFICATIONS

FUNCTIONAL SPECIFICATIONS

	Set Point Range	
Supply Pressure	2-200 psig [0.15-1400 BAR] (15-1400 kPa)	300-400 psig [21-28 BAR] (2100-2800 kPa)
System Pressure (Max.)	300 psig [21.0 BAR] (2100 kPa)	500 psig [35.0 BAR] (3500 kPa)
Flow Capacity (SCFM)	40 (68 m ³ /HR) @ 100 psig, [7.0BAR], (700 kPa) system pressure	
Ambient Temperature	-40° F to +200° F (-40° C to +93° C)	

PERFORMANCE SPECIFICATIONS

Sensitivity	Less than 1/8" (.32 cm) Water Column
Materials of Construction	Body and Housing Aluminum Trim Zinc Plated Steel, Brass Diaphragms Nitrile on Dacron

TYPICAL APPLICATION

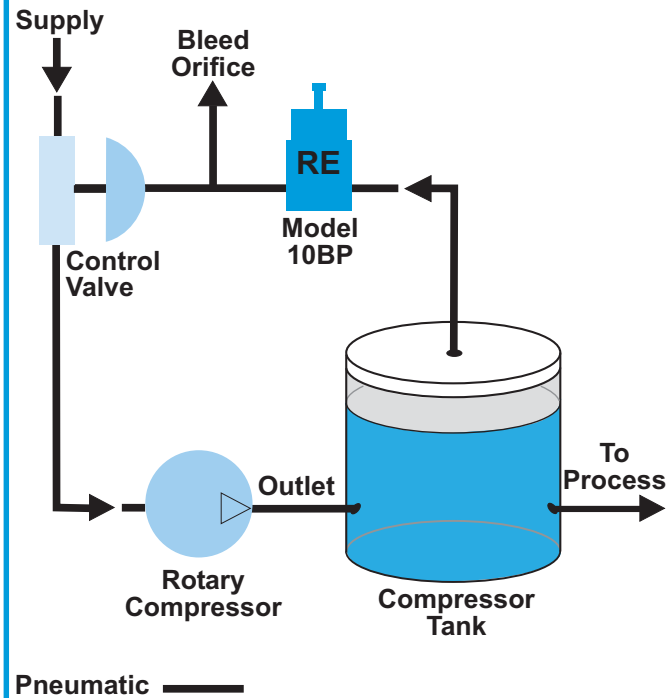

Figure 4. Model 10BP Application

TYPICAL APPLICATION

The Model 10BP regulator controls the air pressure in a manufacturing process.

The Control Valve supplies air to a Rotary Compressor. The Rotary Compressor sends outlet air to the Compressor Tank. When the pressure in the Compressor Tank reaches the required value, the Model 10BP opens and relieves any excess pressure. The excess pressure passes to the control valve that regulates flow from the air supply to the Rotary Compressor.

When the Control Valve closes, outlet pressure from the Rotary Compressor drops and closes the Model 10BP. Air in the line between the Model 10BP and the Control Valve vents through the Bleed Orifice. Then the Control Valve opens to increase flow to the Rotary Compressor. For more information, see Figure 4.

ORDERING INFORMATION

Catalog Number 1 0 2 B P

Pressure Range _____

psig	[BAR]	(kPa)	
0-2	[0-0.1]	(0-15)	(1)
0-10	[0-0.7]	(0-70)	(2)
0-20	[0-1.5]	(0-150)	(0)
.5-30	[.03-2]	(3-200)	(3)
1-60	[0.1-4]	(10-400)	(4)
2-150	[0.1-10]	(15-1000)	(6)
3-200	[0.2-15]	(20-1500)	(7)
5-300	[0.3-21]	(35-2100)	(8)
5-400	[0.3-28]	(35-2800)	(9)

Pipe Size

1/4" NPT	(2)
3/8" NPT	(3)
1/2" NPT	(4)

Options _____

Tamper Proof	(T)
Silicone Elastomers ¹	(A)
Fluorocarbon (Viton) Elastomers	(J)
BSPT (Tapered)	(U)
BSPP (Parallel) ²	(H)

¹Maximum System Pressure - 75 psig, [5.0 BAR], (500 kPa)

²BSPP Threads in Inlet & Outlet Ports Only. Others BSPT.

INSTALLATION

For installation instructions, see the *Fairchild Model 10BP Pneumatic Precision Back Pressure Regulator Installation, Operation and Maintenance Instructions, IS-100010BP*.

ISO 9001:2000
Certified



FAIRCHILD
INDUSTRIAL PRODUCTS COMPANY

3920 WEST POINT BLVD. WINSTON-SALEM, NC 27103-6708
TEL 336-659-3400 FAX 336-659-9323

www.fairchildproducts.com



ISO 9001:2000
FM NO. 25571

CS-100010BP
Litho in USA
Rev. U 6/04