

FAIRCHILD

PNEUMATIC VOLUME BOOSTER

Model 4500A

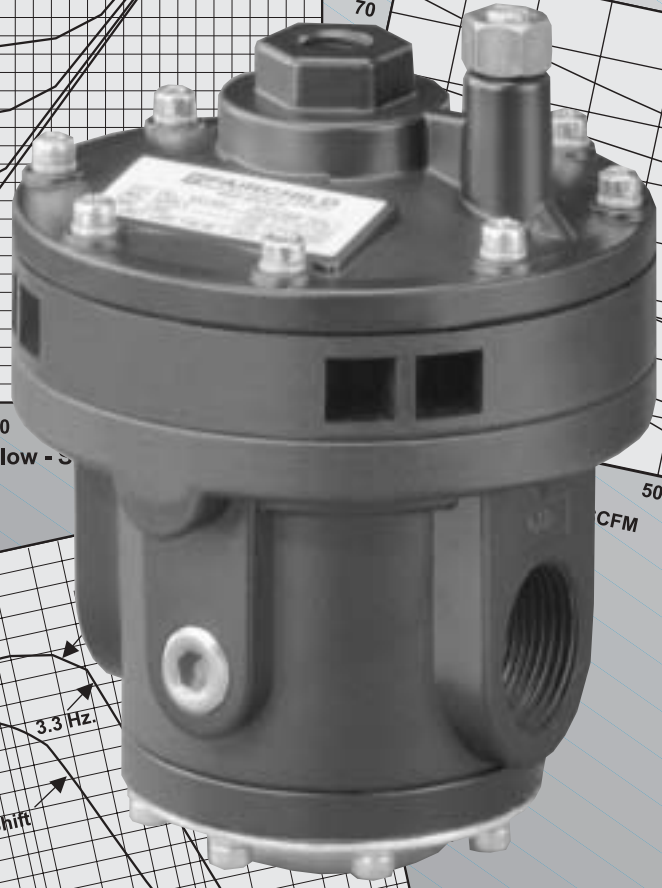
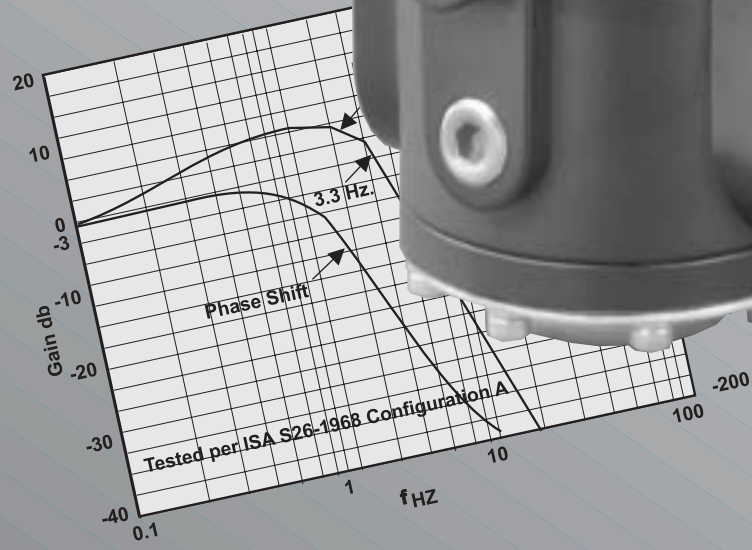
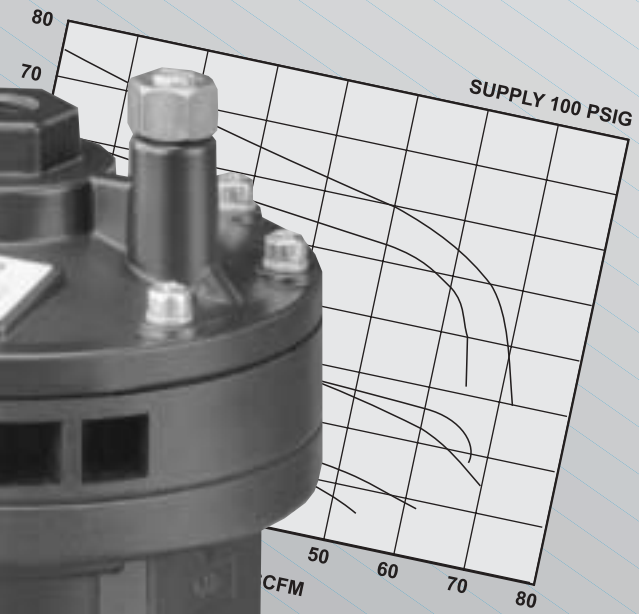
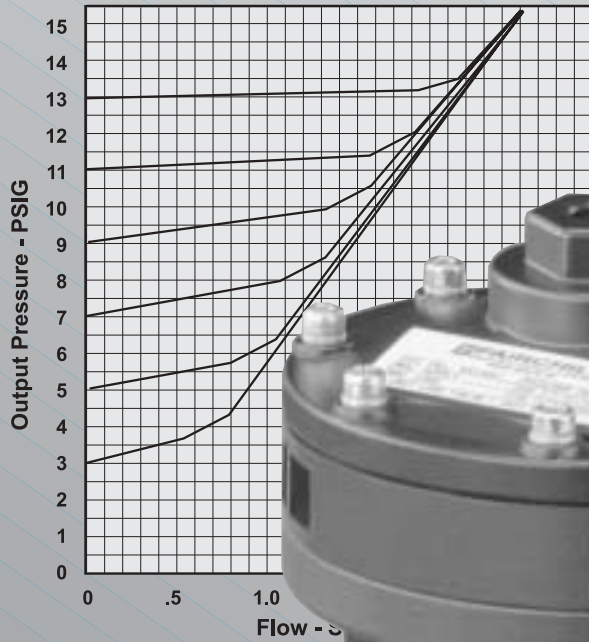

FAIRCHILD
INDUSTRIAL PRODUCTS COMPANY

CROSS SECTION

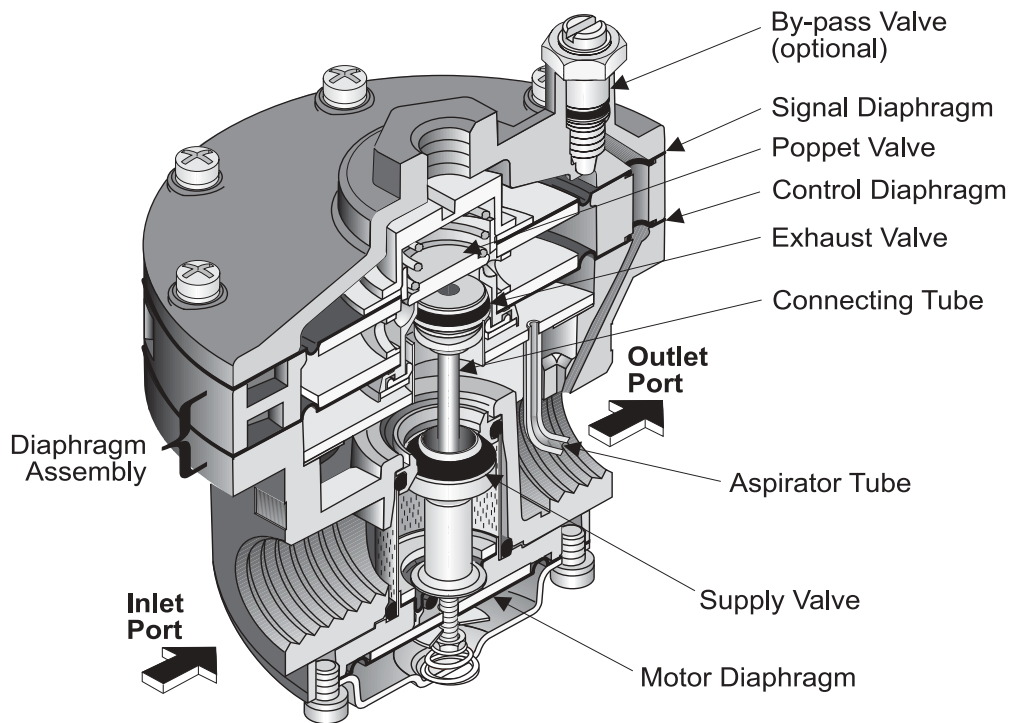

Figure 1. Model 4500A Detail Drawing

GENERAL INFORMATION

The Model 4500A Pneumatic Volume Booster reproduces a pneumatic signal in a 1:1 ratio or in multiplying or dividing ratios. It is ideal for systems requiring input isolation or increased flow capacity.

The Model 4500A has the following features:

- Five (5) signal to output ratios meet most control element requirements.
- Control sensitivity of 1" water column allows use in precision applications.
- Large Supply and Exhaust Valves provide high forward and exhaust flows.
- Soft Supply and Exhaust Valve seats minimize air consumption.
- A balanced Supply Valve minimizes the effect of supply pressure variation.
- An Aspirator Tube compensates downstream pressure droop under flow conditions.
- A separate Control Chamber isolates the diaphragm from the main flow to eliminate hunting and buzzing.
- Optional remote feedback port minimizes pressure drop at final control element under flow conditions.

- The optional adjustable By-pass Valve lets you tune for optimum dynamic response. (1:1 Ratio Only)
- Unit construction lets you service the Model 4500A without removing it from the line.

OPERATING PRINCIPLES

When signal pressure on the top of the Signal Diaphragm creates a downward force on the Diaphragm Assembly, the Supply Valve opens. Output pressure flows through the Outlet Port and the Aspirator Tube to the Control Chamber to create an upward force on the bottom of the Control Diaphragm. When the setpoint is reached, the force of the signal pressure that acts on the top of the Signal Diaphragm balances with the force of the output pressure that acts on the bottom of the Control Diaphragm to close the Supply Valve.

When the output pressure increases above the signal pressure, the Diaphragm Assembly moves upward to close the Supply Valve and open the Exhaust Valve. Because the Poppet Valve is closed, pressure flows down the Connecting Tube to the bottom of the Motor Diaphragm. This pressure keeps the Supply Valve tightly closed while in the exhaust mode. The Poppet Valve opens and excess output pressure exhausts through the vent in the side of the unit until it reaches the setpoint. For more information, see Figure 1.

OUTLINE DIMENSIONS

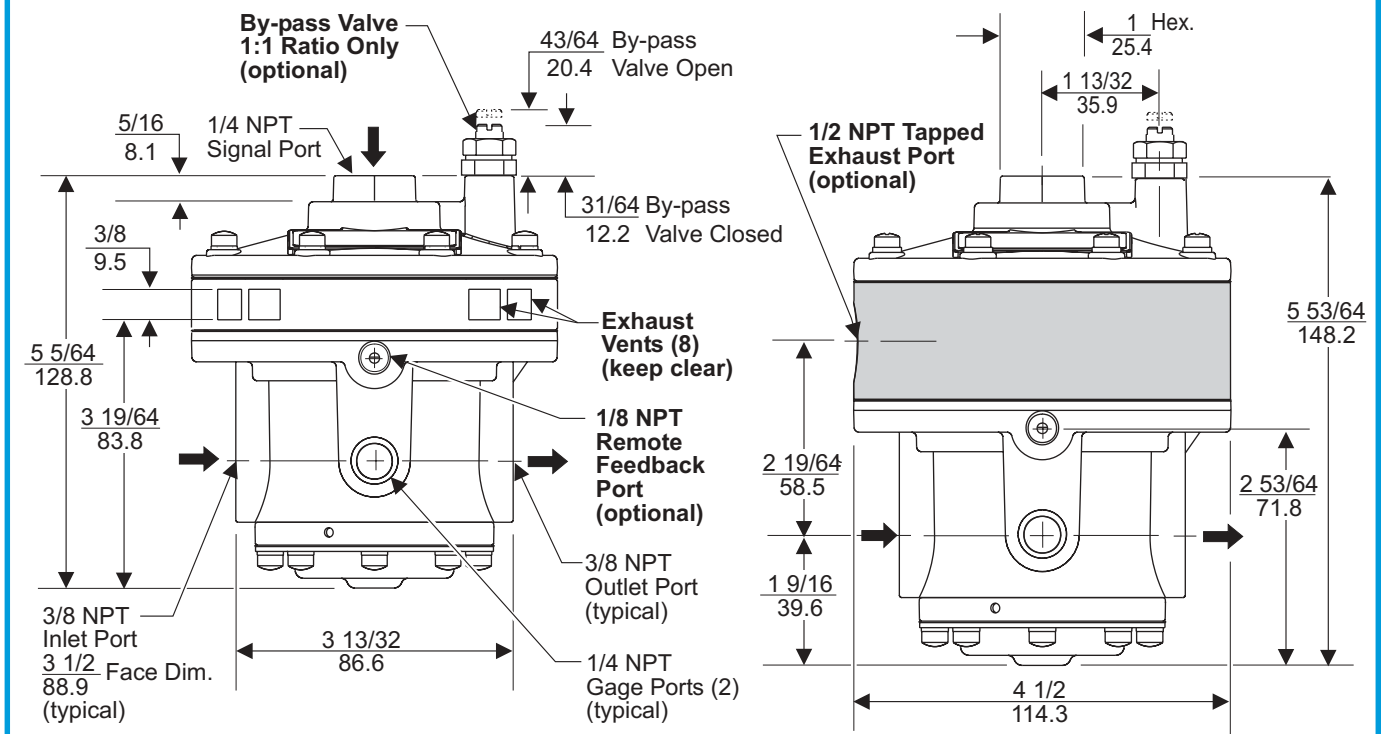

Figure 2. Model 4500A Outline Dimensions

SPECIFICATIONS

FUNCTIONAL SPECIFICATIONS

		Ratio	1:1	1:2	1:3	2:1	3:1
Maximum Output Pressure	psig		150	150	150	75	50
	[BAR] (kPa)		[10.0] (1000)	[10.0] (1000)	[10.0] (1000)	[5.0] (500)	[3.5] (350)
Maximum Supply Pressure	psig		250	250	250	250	250
	[BAR] (kPa)		[17.0] (1700)	[17.0] (1700)	[17.0] (1700)	[17.0] (1700)	[17.0] (1700)
Flow Capacity 100 psig, [7.0 BAR], (700kPa) supply, 20 psig, [1.5 BAR], (150kPa) setpoint.	SCFM		150	150	150	150	150
	(m ³ /HR)		(255)	(255)	(255)	(255)	(76.5)
Exhaust Capacity Downstream Pressure 5 psig, [.35 BAR], (35 kPa) above 20 psig, [1.5 BAR], (150kPa) setpoint.	SCFM		40	40	40	40	40
	(m ³ /HR)		(65.2)	(65.2)	(65.2)	(65.2)	(18.7)

PERFORMANCE SPECIFICATIONS

		Ratio	1:1	1:2	1:3	2:1	3:1	
Sensitivity Water Column	1"		1"	2"	3"	2"	2"	
	(cm)		(2.54)	(5.08)	(7.62)	(5.08)	(5.08)	
Ratio Accuracy % of 100 psig, [7.0 BAR], (700 kPa) output span.			3.0	3.0	3.0			
	% of output span with 100 psig, [7.0 BAR], (700kPa) input span.					3.0	3.0	
Supply Pressure Effect for change of 100 psig [7.0 BAR], (700 kPa).	psig		0.10	0.20	0.30	0.10	0.10	
	[BAR] (kPa)		[.007] (0.7)	[.014] (1.4)	[.021] (2.1)	[.007] (0.7)	[.007] (0.7)	
Ambient Temperature		-40°F to 200°F (-40°C to 93.3°C)						
Materials of Construction	Body & Housing	Aluminum						
	Trim	Zinc Plated Steel, Brass						
	Diaphragm	Nitrile on Dacron						

TYPICAL APPLICATION

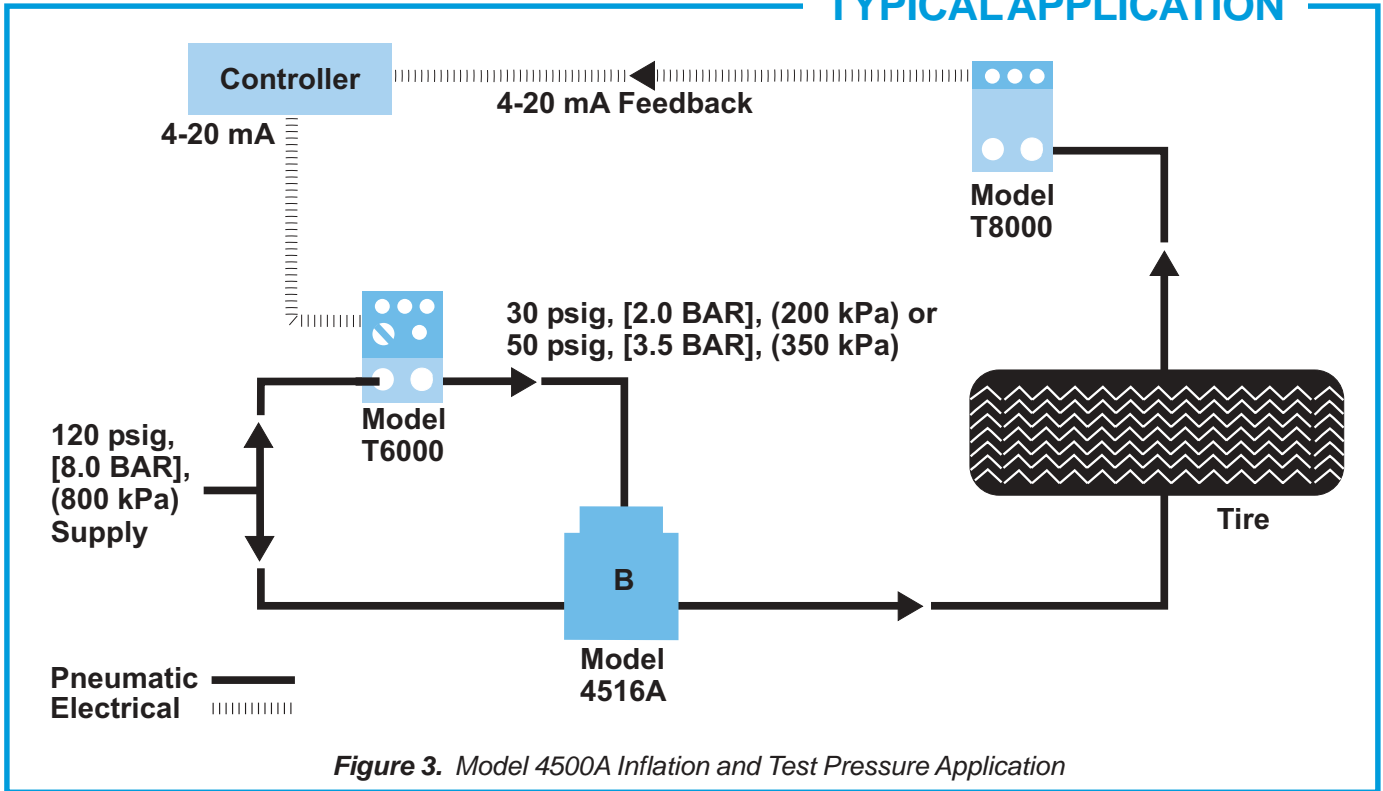

TYPICAL APPLICATION

The Model 4500A controls inflation and test pressures of a tire testing machine. An electronic controller transmits a 4-20 mA signal to a TA6000-405 transducer. The transducer sends an output signal to a Model 4516A Booster. The booster provides a set pressure to set the tire on the bead. The booster also reduces and maintains the pressure during testing. The T8000 senses the tire pressure and sends a 4-20mA signal to the Controller to close the loop. For more information, see Figure 3.

INSTALLATION

For installation instructions, see the *Model 4500A Pneumatic Volume Booster IOM, IS-2004500A*.

ORDERING INFORMATION

Catalog Number	45	<input type="checkbox"/>	<input type="checkbox"/>	A	<input type="checkbox"/>
Ratio					
1:1			(1)		
1:2			(2)		
1:3			(3)		
2:1			(4)		
3:1			(5)		
Pipe Size					
3/8 NPT			(3)		
1/2 NPT			(4)		
3/4 NPT			(6)		
Options					
Tapped Exhaust					(E)
By-pass Valve ¹					(I)
Feedback					(P)
BSPT (Tapered)					(U)
BSPP (Parallel) ²					(H)

¹ For 1:1 Ratio Only.

² BSPP Threads in Inlet & Outlet. Others BSPT.



FM NO. 25571

CS-2004500A
Litho in USA
Rev. B 11/02