

LM1583

3A, 23V, 385KHz Step-Down Converter

DESCRIPTION

The LM1583 is a step-down regulator with a built-in internal Power MOSFET. It achieves 3A of continuous output current over a wide input supply range with excellent load and line regulation.

Current mode operation provides fast transient response and eases loop stabilization.

Fault condition protection includes cycle-by-cycle current limiting and thermal shutdown. An adjustable soft-start reduces the stress on the input source at startup. In shutdown mode the regulator draws 20 μ A of supply current.

The LM1583 requires a minimum number of external components, providing a compact solution.

FEATURES

- 3A Output Current
- Programmable Soft-Start
- 100m Ω Internal Power MOSFET Switch
- Stable with Low ESR Output Ceramic Capacitors
- Up to 95% Efficiency
- 20 μ A Shutdown Mode
- Fixed 385KHz Frequency
- Thermal Shutdown
- Cycle-by-Cycle Over Current Protection
- Wide 4.75V to 23V Operating Input Range
- Output Adjustable from 1.22V to 21V
- Under-Voltage Lockout

APPLICATIONS

- Distributed Power Systems
- Battery Chargers
- Pre-Regulator for Linear Regulators

TOP VIEW
SOIC8/PDIP8

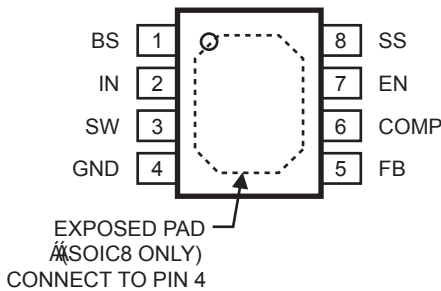

ORDERING INFORMATION

Part Number*	Package	Top Marking	Free Air Temperature (T _A)
LM1583M	SOIC8	LM1583M	-40°C to +85°C
LM1583T	SOIC8	LM1583T	-40°C to +85°C
LM1583P	PDIP8	LM1583P	-40°C to +85°C

TYPICAL APPLICATION

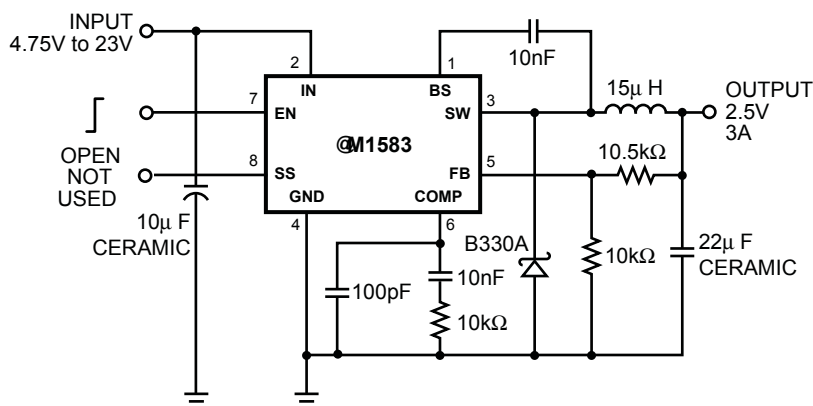

Efficiency Curve

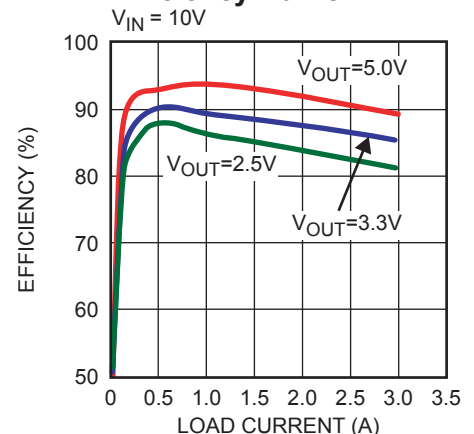

Absolute Maximum Ratings (Note 1)

Supply Voltage V_{IN}	-0.3V to 28V
Switch Voltage V_{SW}	-1V to $V_{IN}+0.3V$
Boost Voltage V_{BS}	$V_{SW}-0.3V$ to $V_{SW}+6V$
All Other Pins	-0.3V to 6V
Junction Temperature	150°C
Lead Temperature	260°C
Storage Temperature	-65°C to 150°C

Recommended Operating Conditions (Note 2)

Input Voltage V_{IN}	4.75V to 23V
Ambient Operating Temperature	-40°C to +85°C

Package Thermal Characteristics (Note 3)

(SOIC8)	
Thermal Resistance, θ_{JA}	105°C/W
Thermal Resistance, θ_{JA} (w/ Exposed Pad)	50°C/W
Thermal Resistance, θ_{JC} (w/ Exposed Pad)	10°C/W
(PDIP8)	
Thermal Resistance θ_{JA}	95°C/W
Thermal Resistance θ_{JC}	55°C/W

Electrical Characteristics (Unless otherwise specified $V_{IN}=12V$, $T_A=25^\circ C$)

Parameters	Condition	Min	Typ	Max	Units
Shutdown Supply Current	$V_{EN} = 0V$		20	31	μA
Supply current	$V_{EN} = 2.6V$; $V_{FB} = 1.4V$		1.0	1.2	mA
Feedback Voltage	$4.75V \leq V_{IN} \leq 23V$; $V_{COMP} < 2V$	1.194	1.222	1.250	V
Error Amplifier Voltage Gain			400		V/V
Error Amplifier Transconductance	$\Delta I_{COMP} = \pm 10 \mu A$	500	800	1120	$\mu A/V$
High Side Switch On Resistance			100		m Ω
Low Side Switch On Resistance			10		Ω
High Side Switch Leakage Current	$V_{EN}=0V$; $V_{SW}=0V$		0	10	μA
Current Limit			5.5		A
Current Sense to COMP Transconductance			3.8		A/V
Oscillation Frequency		335	385	435	KHz
Short Circuit Oscillation Frequency	$V_{FB} = 0V$	25	40	55	KHz
Maximum Duty Cycle	$V_{FB} = 1.0V$		90		%
Minimum Duty Cycle	$V_{FB} = 1.5V$			0	%
EN Threshold Voltage		0.9	1.2	1.5	V
Enable Pull Up Current	$V_{EN} = 0V$	1.1	1.8	2.5	μA
Under Voltage Lockout Threshold	V_{IN} Rising	2.37	2.54	2.71	V
Under Voltage Lockout Threshold Hysteresis			210		mV
Soft Start Period	$C_{SS} = 0.1\mu F$		10		ms
Thermal Shutdown			160		$^\circ C$

Note 1. Exceeding these ratings may damage the device.

Note 2. The device is not guaranteed to function outside its operating rating.

Note 3. Measured on approximately 1" square of 1 oz. Copper with exposed pad area of 6.8mm² (10.5mils²)

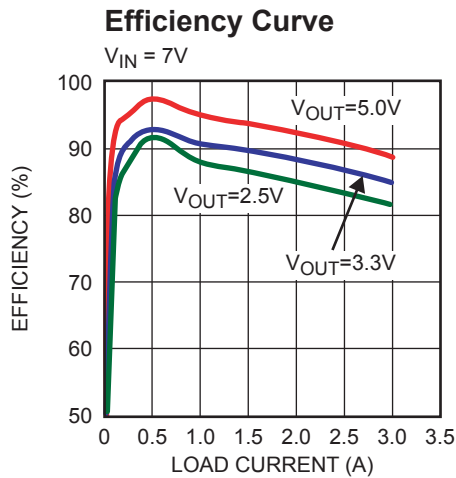
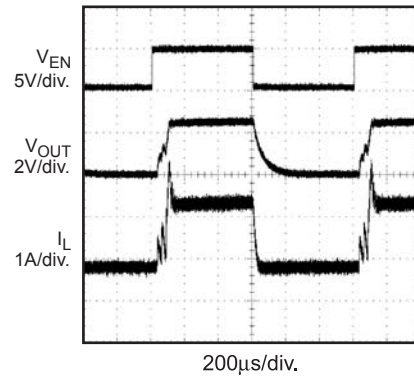
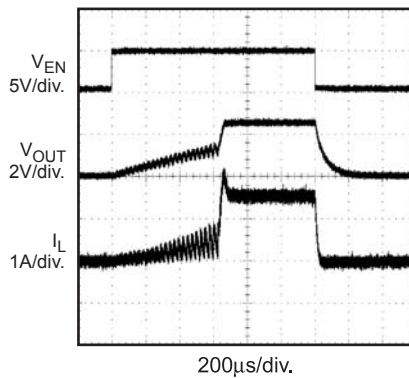
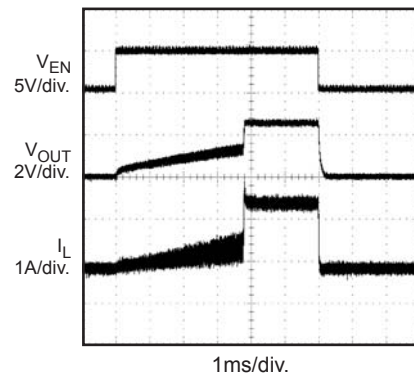
TYPICAL PERFORMANCE CHARACTERISTICS

Soft-Start
 C_{SS} Open, $V_{IN} = 10V$, $V_{OUT} = 3.3V$,
 1.5A Resistive Load

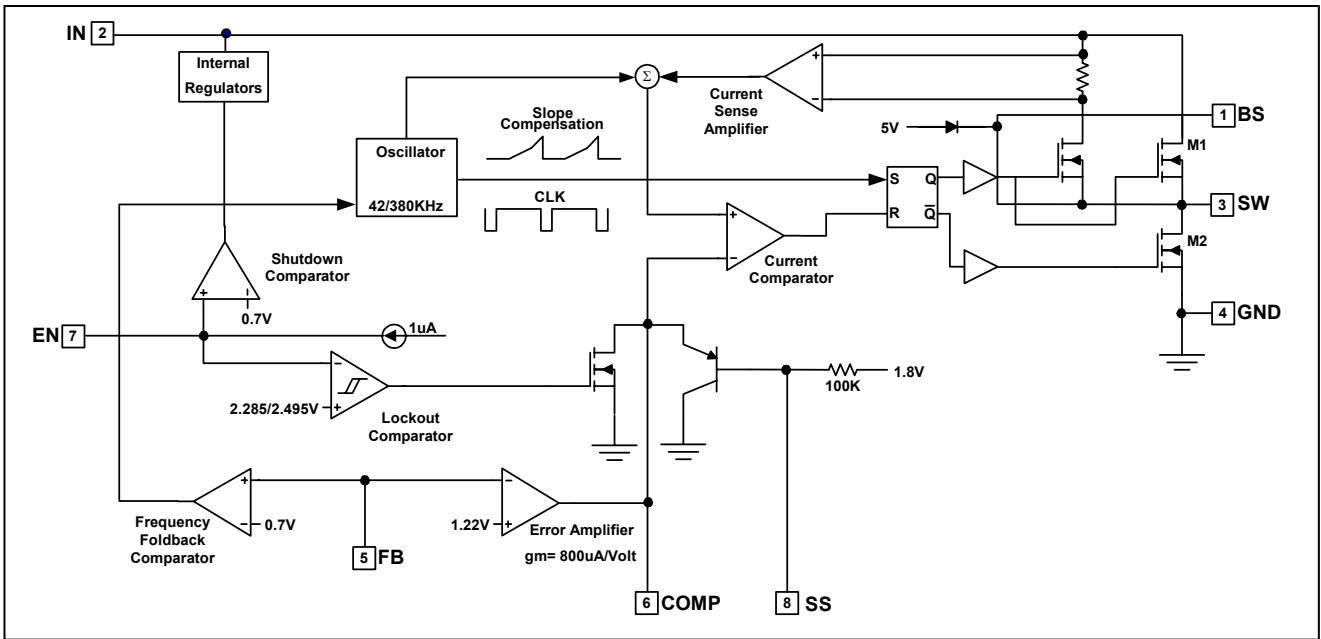
Soft-Start
 $C_{SS} = 0.01\mu F$, $V_{IN} = 10V$, $V_{OUT} = 3.3V$,
 1.5A Resistive Load

Soft-Start
 $C_{SS} = 0.1\mu F$, $V_{IN} = 10V$, $V_{OUT} = 3.3V$,
 1.5A Resistive Load

Table 1: Pin Designators

#	Name	Description
1	BS	High-Side Gate Drive Boost Input. BS supplies the drive for the high-side n-channel MOSFET switch. Connect a 4.7nF or greater capacitor from SW to BS to power the high side switch.
2	IN	Power Input. IN supplies the power to the IC, as well as the step-down converter switches. Drive IN with a 4.75V to 23V power source. Bypass IN to GND with a suitably large capacitor to eliminate noise on the input to the IC. See <i>Input Capacitor</i>
3	SW	Power Switching Output. SW is the switching node that supplies power to the output. Connect the output LC filter from SW to the output load. Note that a capacitor is required from SW to BS to power the high-side switch.
4	GND	Ground. (Note: Connect the exposed pad on backside to Pin 4).
5	FB	Feedback Input. FB senses the output voltage to regulate that voltage. Drive FB with a resistive voltage divider from the output voltage. The feedback threshold is 1.222V. See <i>Setting the Output Voltage</i>
6	COMP	Compensation Node. COMP is used to compensate the regulation control loop. Connect a series RC network from COMP to GND to compensate the regulation control loop. In some cases, an additional capacitor from COMP to GND is required. See <i>Compensation</i>
7	EN	Enable Input. EN is a digital input that turns the regulator on or off. Drive EN high to turn on the regulator, drive it low to turn it off. For automatic startup, leave EN unconnected.
8	SS	Soft Start Control Input. SS controls the soft start period. Connect a capacitor from SS to GND to set the soft-start period. A 0.1µF capacitor sets the soft-start period to 10ms. To disable the soft-start feature, leave SS unconnected.

Figure 2: Functional Block

Functional Description

The LM1583 is a current-mode step-down regulator. It regulates input voltages from 4.75V to 23V down to an output voltage as low as 1.22V, and is able to supply up to 3A of load current.

The LM1583 uses current-mode control to regulate the output voltage. The output voltage is measured at FB through a resistive voltage divider and amplified through the internal error amplifier. The output current of the transconductance error amplifier is presented at COMP where a network compensates the regulation control system. The voltage at COMP is compared to the switch current measured internally to control the output voltage.

The converter uses an internal n-channel MOSFET switch to step-down the input voltage to the regulated output voltage. Since the MOSFET requires a gate voltage greater than the input voltage, a boost capacitor connected between SW and BS drives the gate. The capacitor is internally charged while SW is low.

An internal 10Ω switch from SW to GND is used to insure that SW is pulled to GND when SW is low to fully charge the BS capacitor.

Application Information

Setting the Output Voltage

The output voltage is set using a resistive voltage divider from the output voltage to FB (see Figure 3). The voltage divider divides the output voltage down by the ratio:

$$V_{FB} = V_{OUT} * R2 / (R1 + R2)$$

Thus the output voltage is:

$$V_{OUT} = 1.222 * (R1 + R2) / R2$$

R2 can be as high as 100KΩ, but a typical value is 10KΩ. Using that value, R1 is determined by:

$$R1 \sim 8.18 * (V_{OUT} - 1.222) \text{ (K}\Omega\text{)}$$

For example, for a 3.3V output voltage, R2 is 10KΩ, and R1 is 17KΩ.

Inductor

The inductor is required to supply constant current to the output load while being driven by the switched input voltage. A larger value inductor results in less ripple current that in turn results in lower output ripple voltage. However, the larger value inductor has a larger physical size, higher series resistance, and/or lower saturation current. Choose an inductor that does not saturate under the worst-case load conditions. A good rule for determining the inductance is to allow the peak-to-peak ripple current in the inductor to be approximately 30% of the maximum load current. Also, make sure that the peak inductor current (the load current plus half the peak-to-peak inductor ripple current) is below the TBDA minimum current limit. The inductance value can be calculated by the equation:

$$L = (V_{OUT}) * (V_{IN} - V_{OUT}) / V_{IN} * f * \Delta I$$

Where V_{OUT} is the output voltage, V_{IN} is the input voltage, f is the switching frequency, and ΔI is the peak-to-peak inductor ripple current. Table 2 lists a number of suitable inductors from various manufacturers.

Table 2: Inductor Selection Guide

Vendor/ Model	Core Type	Core Material	Package Dimensions (mm)		
			W	L	H
Sumida					
CR75	Open	Ferrite	7.0	7.8	5.5
CDH74	Open	Ferrite	7.3	8.0	5.2
CDRH5D28	Shielded	Ferrite	5.5	5.7	5.5
CDRH5D28	Shielded	Ferrite	5.5	5.7	5.5
CDRH6D28	Shielded	Ferrite	6.7	6.7	3.0
CDRH104R	Shielded	Ferrite	10.1	10.0	3.0
Toko					
D53LC Type A	Shielded	Ferrite	5.0	5.0	3.0
D75C	Shielded	Ferrite	7.6	7.6	5.1
D104C	Shielded	Ferrite	10.0	10.0	4.3
D10FL	Open	Ferrite	9.7	11.5	4.0
Coilcraft					
DO3308	Open	Ferrite	9.4	13.0	3.0
DO3316	Open	Ferrite	9.4	13.0	5.1

Input Capacitor

The input current to the step-down converter is discontinuous, and so a capacitor is required to supply the AC current to the step-down converter while maintaining the DC input voltage. A low ESR capacitor is required to keep the noise at the IC to a minimum. Ceramic capacitors are preferred, but tantalum or low-ESR electrolytic capacitors may also suffice.

The input capacitor value should be greater than 10 μ F. The capacitor can be electrolytic, tantalum or ceramic. However since it absorbs the input switching current it requires an adequate ripple current rating. Its RMS current rating should be greater than approximately 1/2 of the DC load current.

For insuring stable operation C2 should be placed as close to the IC as possible. Alternately a smaller high quality ceramic 0.1 μ F capacitor may be placed closer to the IC and a larger capacitor placed further away. If using this technique, it is recommended that the larger capacitor be a tantalum or electrolytic type. All ceramic capacitors should be placed close to the LM1583.

Output Capacitor

The output capacitor is required to maintain the DC output voltage. Low ESR capacitors are preferred to keep the output voltage ripple low. The characteristics of the output capacitor also affect the stability of the regulation control system. Ceramic, tantalum, or low ESR electrolytic capacitors are recommended. In the case of ceramic capacitors, the impedance at the switching frequency is dominated by the capacitance, and so the output voltage ripple is mostly independent of the ESR. The output voltage ripple is estimated to be:

$$V_{RIPPLE} \sim 1.4 * V_{IN} * (f_{LC}/f_{SW})^2$$

Where V_{RIPPLE} is the output ripple voltage, V_{IN} is the input voltage, f_{LC} is the resonant frequency of the LC filter, f_{SW} is the switching frequency. In the case of tantalum or low-ESR electrolytic capacitors, the ESR dominates the impedance at the switching frequency, and so the output ripple is calculated as:

$$V_{RIPPLE} \approx \Delta I * R_{ESR}$$

Where V_{RIPPLE} is the output voltage ripple, ΔI is the inductor ripple current, and R_{ESR} is the equivalent series resistance of the output capacitors.

Output Rectifier Diode

The output rectifier diode supplies the current to the inductor when the high-side switch is off. To reduce losses due to the diode forward voltage and recovery times, use a Schottky rectifier.

Table 3 provides the Schottky rectifier part numbers based on the maximum input voltage and current rating.

Table 3: Schottky Rectifier Selection Guide

V_{IN} (Max)	2A Load Current		3A Load Current	
	Part Number	Vendor	Part Number	Vendor
15V	30BQ15	4		
20V	B220	1	B320	1
	SK23	6	SK33	1, 6
	SR22	6	SS32	3
26V	20BQ030	4	B330	1
	B230	1	B340L	1
	SK23	6	MBRD330	4, 5
	SR23	3, 6	SK33	1, 6
	SS23	2, 3	SS33	2, 3

Table 4 lists some rectifier manufacturers.

Table 4: Schottky Diode Manufacturers

#	Vendor	Web Site
1	Diodes, Inc.	www.diodes.com
2	Fairchild Semiconductor	www.fairchildsemi.com
3	General Semiconductor	www.gensemi.com
4	International Rectifier	www.irf.com
5	On Semiconductor	www.onsemi.com
6	Pan Jit International	www.panjit.com.tw

Choose a rectifier whose maximum reverse voltage rating is greater than the maximum input voltage, and whose current rating is greater than the maximum load current.

Compensation

The system stability is controlled through the COMP pin. COMP is the output of the internal transconductance error amplifier. A series capacitor-resistor combination sets a pole-zero combination to control the characteristics of the control system.

The DC loop gain is:

$$A_{VDC} = (V_{FB} / V_{OUT}) * A_{VEA} * G_{CS} * R_{LOAD}$$

Where:

- V_{FB} is the feedback threshold voltage, 1.222V
- V_{OUT} is the desired output regulation voltage
- A_{VEA} is the transconductance error amplifier voltage gain, 400 V/V
- G_{CS} is the current sense gain, (roughly the output current divided by the voltage at COMP), 3.8 A/V
- R_{LOAD} is the load resistance (V_{OUT} / I_{OUT} where I_{OUT} is the output load current)

The system has 2 poles of importance, one is due to the compensation capacitor (C3), and the other is due to the output capacitor (C2). These are:

$$f_{P1} = G_{MEA} / (2\pi * A_{VEA} * C3)$$

Where P1 is the first pole, and G_{MEA} is the error amplifier transconductance (800 μ S).

and

$$f_{P2} = 1 / (2\pi * R_{LOAD} * C2)$$

The system has one zero of importance, due to the compensation capacitor (C3) and the compensation resistor (R3). The zero is:

$$f_{z1} = 1 / (2\pi * R3 * C3)$$

If large value capacitors with relatively high equivalent-series-resistance (ESR) are used, the zero due to the capacitance and ESR of the output capacitor can be compensated by a third pole set by R3 and C6. The pole is:

$$f_{p3} = 1 / (2\pi * R3 * C6)$$

The system crossover frequency (the frequency where the loop gain drops to 1, or 0dB) is important. A good rule of thumb is to set the crossover frequency to approximately 1/5 of the switching frequency. In this case, the switching frequency is 385KHz, so use a crossover frequency, f_c , of 40KHz. Lower crossover frequencies result in slower response and worse transient load recovery. Higher crossover frequencies can result in instability.

Table 5: Compensation Values for Typical Output Voltage/Capacitor Combinations

V _{OUT}	C5	R3	C3	C4
2.5V	22µF Ceramic	3.9KΩ	3.9nF	None
3.3V	22µF Ceramic	4.7KΩ	3.3nF	None
5V	22µF Ceramic	7.5KΩ	2.2nF	None
12V	22µF Ceramic	10KΩ	2.7nF	None
2.5V	47µF SP-Cap	8.2KΩ	1.8nF	None
3.3V	47µF SP-Cap	10KΩ	1.8nF	None
5V	47µF SP-Cap	10KΩ	2.7nF	None
12V	47µF SP-Cap	10KΩ	5.6nF	None
2.5V	560µF/6.3V (30mΩ ESR)	10KΩ	15nF	1.5nF
3.3V	560µF/6.3V (30mΩ ESR)	10KΩ	18nF	1.5nF
5V	470µF/10V (30mΩ ESR)	10KΩ	27nF	None
12V	220µF/25V (30mΩ ESR)	10KΩ	27nF	None

Choosing the Compensation Components

The values of the compensation components given in Table 5 yield a stable control loop for the output voltage and capacitor given. To optimize the compensation components for conditions not listed in Table 5, use the following procedure:

Choose the compensation resistor to set the desired crossover frequency (See Figure 3). Determine the value by the following equation:

$$R3 = 2\pi * C_{OUT} * V_{OUT} * f_c / (G_{EA} * G_{CS} * V_{FB})$$

Putting in the know constants and setting the crossover frequency to the desired 40kHz:

$$R3 \approx 6.8 \times 10^7 C_{OUT} * V_{OUT}$$

The value of R3 is limited to 10KΩ to prevent output overshoot at startup, so if the value calculated for R3 is greater than 10KΩ, use 10KΩ. In this case, the actual crossover frequency is less than the desired 40kHz, and is calculated by:

$$f_c = R3 * G_{EA} * G_{CS} * V_{FB} / (2\pi * C_{OUT} * V_{OUT})$$

or

$$f_c \approx 5.9 / C_{OUT} * V_{OUT}$$

Choose the compensation capacitor to set the zero to 1/4 of the crossover frequency. Determine the value by the following equation:

$$C3 = 2 / \pi * R3 * f_c \approx 1.59 \times 10^{-5} / R3$$

if R3 is less than 10KΩ, or if R3 = 10KΩ use the following equation:

$$C3 = 4C_{OUT} * V_{OUT} / (R3^2 * G_{EA} * G_{CS} * V_{FB})$$

$$C3 \approx 1.08 \times 10^{-5} C_{OUT} V_{OUT}$$

Determine if the second compensation capacitor, C6 is required. It is required if the ESR zero of the output capacitor happens at less than four times the crossover frequency. Or:

$$8\pi * C_{OUT} * R_{ESR} * f_c \geq 1$$

where R_{ESR} is the equivalent series resistance of the output capacitor.

If this is the case, then add the second compensation resistor. Determine the value by the equation:

$$C6 = C_{OUT} * R_{ESR(max)} / R3$$

Where $R_{ESR(MAX)}$ is the maximum ESR of the output capacitor.

Example:

$$V_{OUT} = 5V$$

$$C_{OUT} = 22\mu F \text{ Ceramic (ESR} = 10m\Omega)$$

$$R3 \approx 6.8 \times 10^7 (22 \times 10^{-6}) (5) = 7480\Omega. \text{ Use the nearest standard value of } 7.5K\Omega.$$

$$C3 \approx 1.59 \times 10^{-5} / 7.5K\Omega = 2.12nF. \text{ Use the nearest standard value of } 2.2nF.$$

$$2\pi C_{OUT} R_{ESR} f_c = .055 \text{ which is less than } 1, \text{ therefore no second compensation capacitor is required.}$$

Figure 3: LM1583 with 22µF, 10V Ceramic Output Capacitor

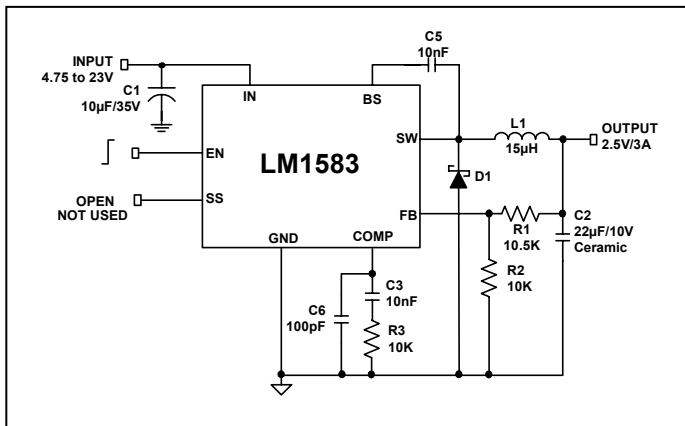
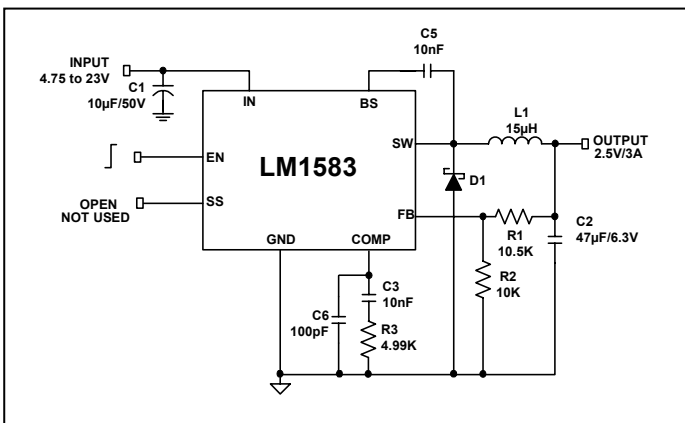

Figure 4: LM1583 with 47µF, 6.3V Special Polymer Output Capacitor



Packaging

SOIC8 or SOIC89 (Exposed Pad)

(With or without Exposed Pad)

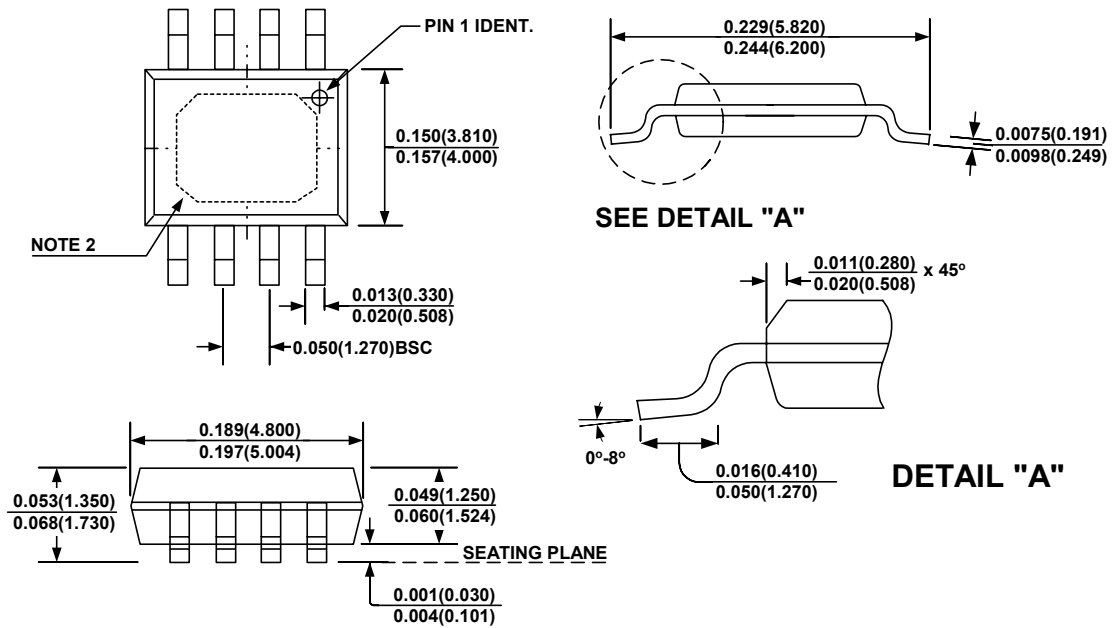

NOTE:

- 1) Control dimension is in inches. Dimension in bracket is millimeters.
- 2) Exposed Pad Option Only (N-Package) ; 2.55+/- 0.25mm x 3.38 +/- 0.44mm.
Recommended Solder Board Area: 2.80mm x 3.82mm = 10.7mm² (16.6mil²)

PDIP8

