

上海季冉实业有限公司
Shanghai Jiran Industry Co., Ltd

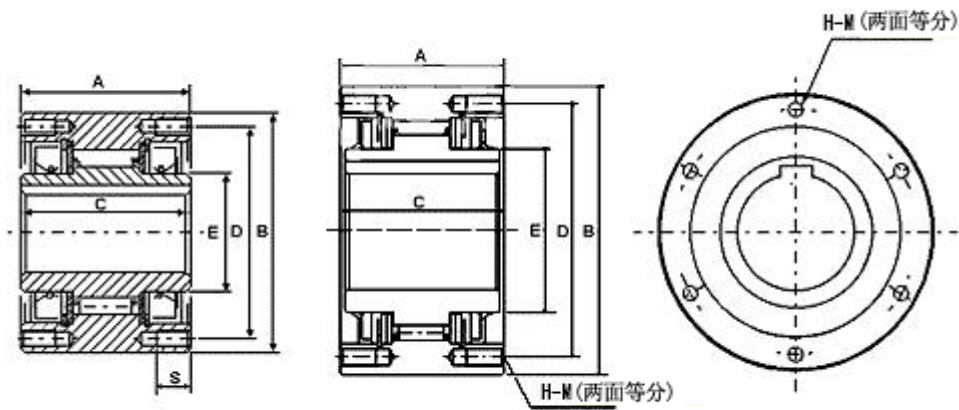

Construct BS30 -50 BS65 - 135



Construct BS160 - 220

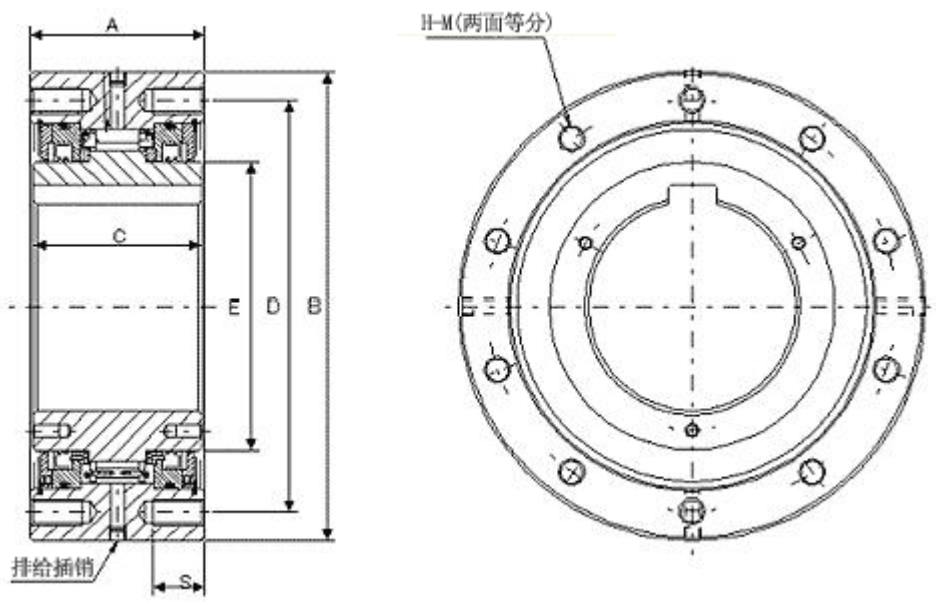

上海季冉实业有限公司
Shanghai Jiran Industry Co., Ltd

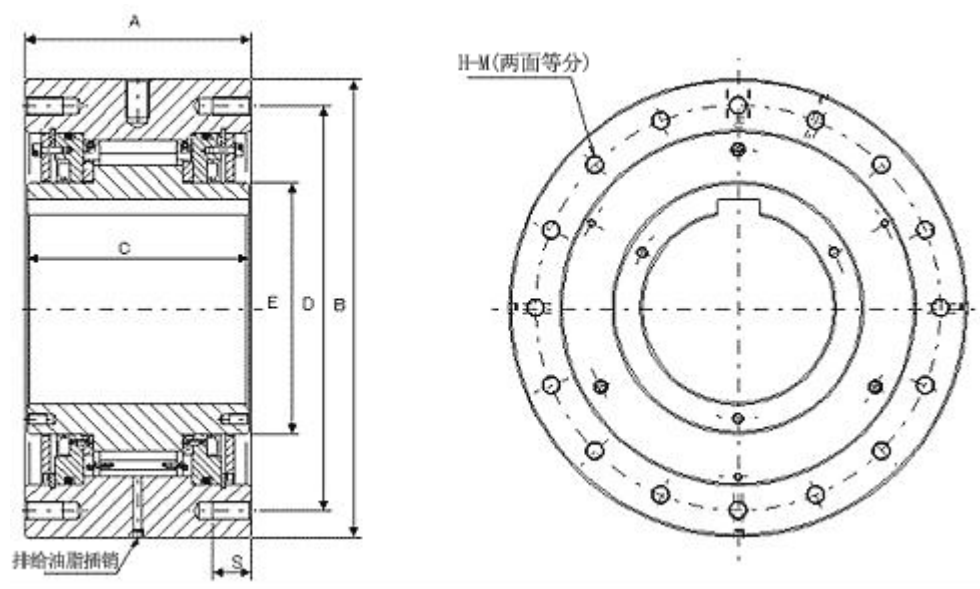

型号	外轮宽	内轮宽	外径	内轮轮毂径	安装丝锥			油脂 螺纹 尺寸	油量 kg	质量 kg	
	A	C			P	C	D				D
BS 30	64	64	90	45	80			4-M6x1.0	-----	2.3	
BS 50	67	67	125	70	110			4-M8x1.25	-----	4.7	
BS 65	90	85	160	90	140			6-M10x1.5	-----	13.0	
BS 75	90	85	170	100	150			6-M10x1.5	-----	14.7	
BS 85	115	110	210	115	185			6-M12x1.75	-----	27.2	
BS 95	115	110	230	130	200			6-M14x2.0	-----	32.2	
BS110	115	110	270	150	220			6-M16x2.0	-----	38.6	
BS135	135	130	320	180	280			8-M16x2.0	-----	76.1	
BS160	135	130	360	220	315			10-M20x2.5	PT1/4	0.12	98.1
BS200	150	145	430	265	380			8-M22x2.5	PT1/4	0.14	167
BS220	235	230	500	290	420			16-M20x2.5	PT1/4	0.8	301
BS250	295	290	600	330	530			16-M24x3.0	PT1/4	1.1	580
BS270	295	290	650	370	575			16-M24x3.0	PT1/4	1.2	620
BS300	295	290	780	470	690			16-M30x3.5	PT1/4	1.3	952
BS335	305	320	850	495	750			16-M36x4.0	PT1/4	1.4	1,140

上海季冉实业有限公司

Shanghai Jiran Industry Co., Ltd

BS350	320	360	930	535	815	70	16-M36x4.0	PT1/4	1.5	1,600
BS425	440	450	1030	635	940	70	18-M36x4.0	油规格	油规格	2,450
BS450	450	480	1,090	645	990	80	18-M42x4.5	油规格	油规格	2,820

■ 传递能力表及轴孔径

型号	允许最大 扭矩	轴孔径 加工范围	标准轴孔径(键槽已加工:注 1)		最高内轮 空转 旋转速度	空转 摩擦 扭矩
	N·m		旧 JIS キー(注 2)	新 JIS キー(注 3)	r/min	N·m
BS 30	294	20~30	30	30	350	0.59
BS 50	784	30~50	45·50	45·50	300	0.98
BS 65	1,570	40~65	40·45·50·55·60·65	40·45·50·55·60·65	340	3.92
BS 75	2,450	50~75	60·65·70·75	60·65·70·75	300	5.88
BS 85	5,890	60~85	70·75·80·85	70·75·80·85	300	7.84
BS 95	7,840	70~95	80·85·90·95	80·85·90·95	250	9.8
BS110	10,800	80~110	85·95·100·105·110	85·90·100·105·110	250	14.7
BS135	15,700	90~135	----	----	200	19.6
BS160	24,500	100~160	----	----	100	34.3
BS200	37,200	100~200	----	----	100	44.1
BS220	49,000	150~220	----	----	80	73.5
BS250	88,200	180~250	----	----	50	93.1
BS270	122,500	200~270	----	----	50	98
BS300	176,400	230~300	----	----	50	108
BS335	264,600	250~335	----	----	50	137
BS350	313,600	250~350	----	----	50	157
BS425	509,600	325~425	----	----	50	216
BS450	686,000	350~450	----	----	50	245

注) 1. 标准库存轴孔加工成品的轴孔公差为 H7。

2. 旧 JIS 平行键 2 种(JIS B1301-1959)。型号显示图例 BS50-50E[E=旧 JIS 规格]

新 JIS 平行键普通型(JIS B1301-1996)(JIS B1301-1976)。

3. 型号显示图例 BS50-50J[J=新 JIS 规格]

标准轴孔径以外发货时, 请与我们联系

4. 轴孔径、键槽尺寸、公差。

5. 粗体字品种为库存品, 细体字产品需订购。

BACK STOP CAM CLUTCH BS-HS series

High Speed and High Performance

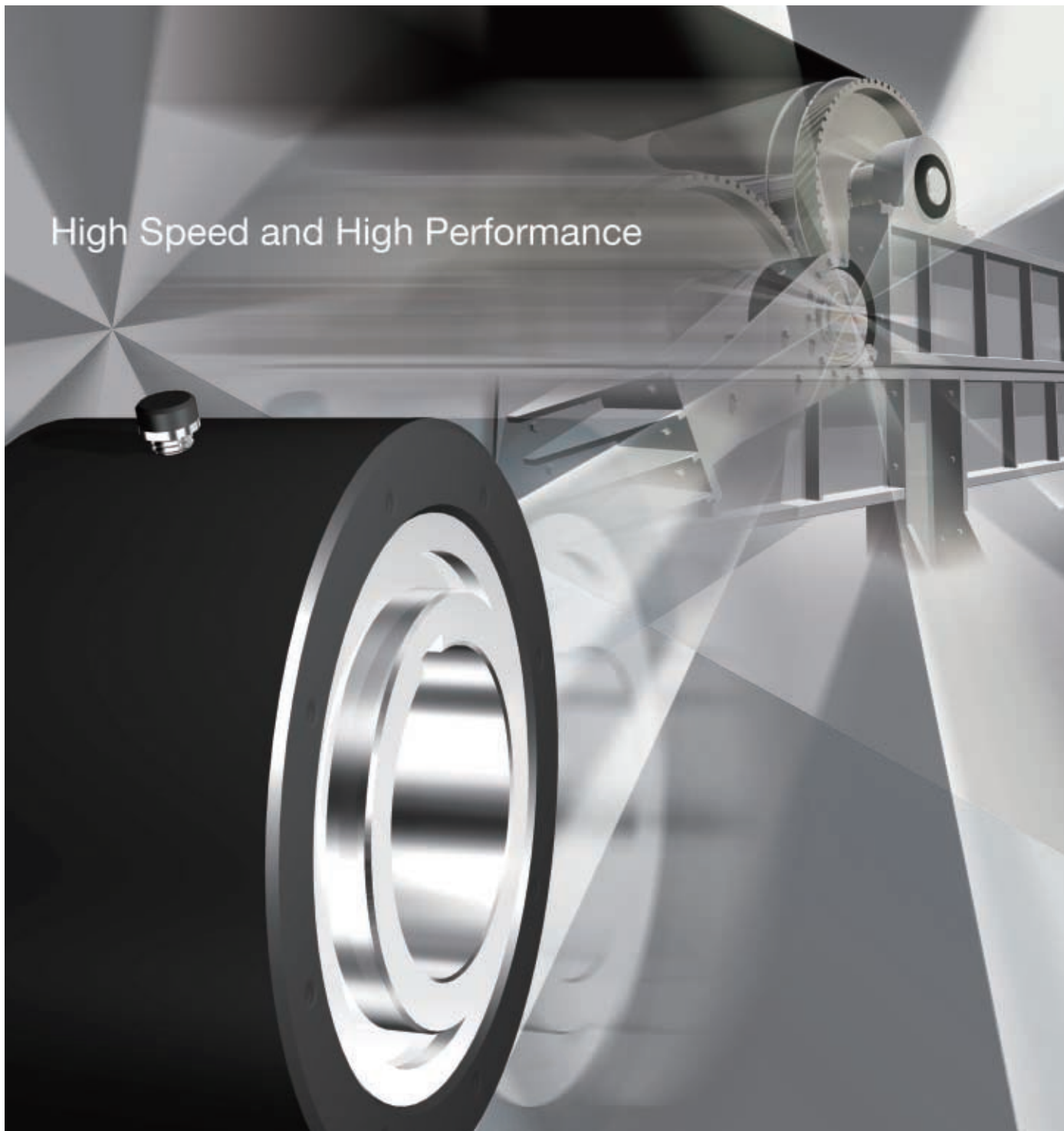

New BS-HS series offer many advantages

High Speed, High performance, High Reliability

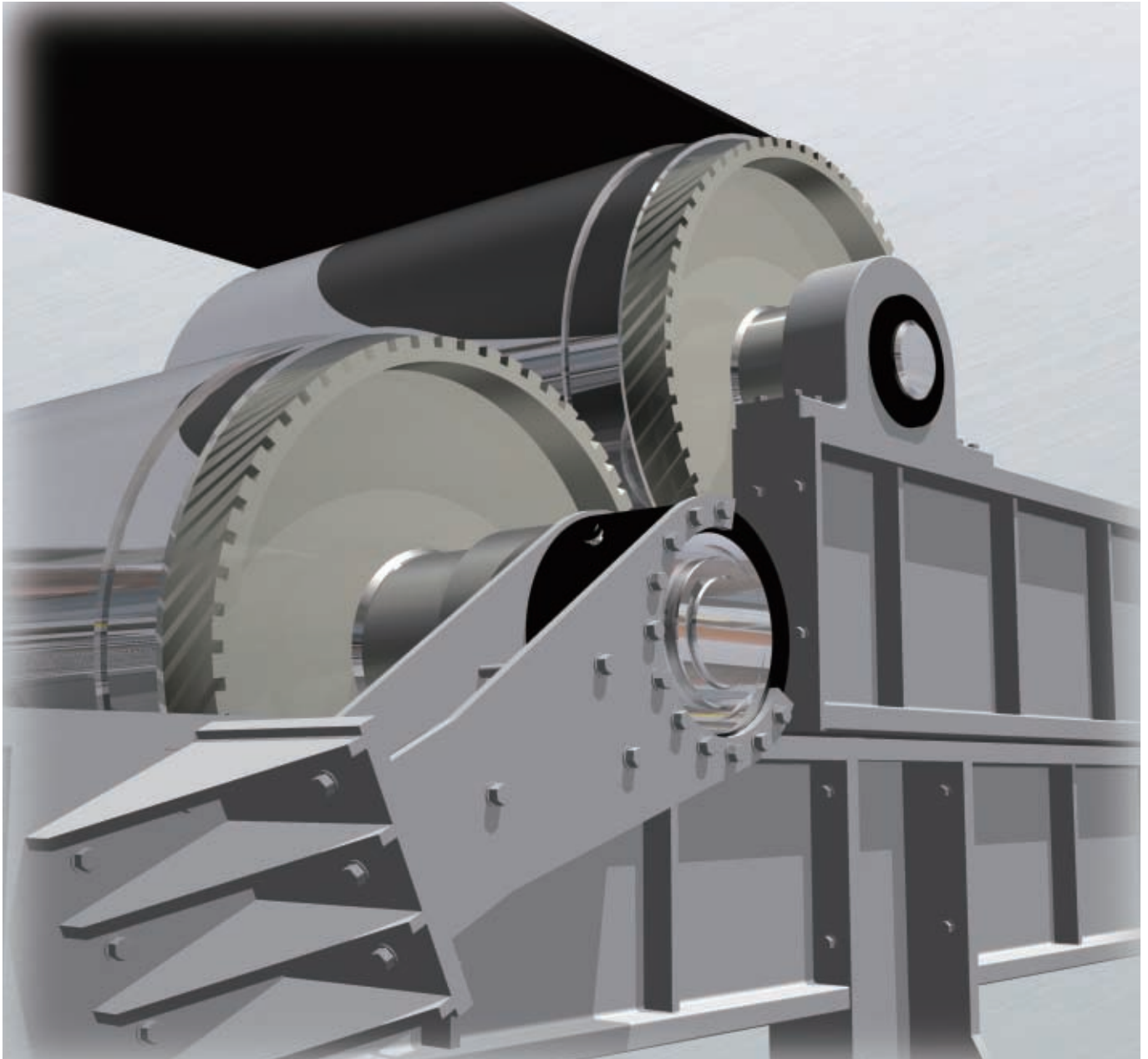

Typical applications

- Belt conveyors for mining, mineral, metals, timber, pulp, wood chip, power stations etc. –
- Bucket elevators for cement, grain etc.
- Large drift conveyors
- Screw pumps

Stop Cam Clutches

not found in conventional models

Design Features

Higher torque/speed capacity

New camcage and bearing supported design will provide higher torque/speed capacity compared with conventional models. This can often permit use of a smaller clutch...providing further cost savings.

In addition, we are providing the double camcage model with higher torque capacity.

Please contact Tsubaki Emerson.

Anti-rollover cam design

Precise formed cams having unique design shape are "anti rollover type", which assure superior durability against heavy shock load in back stopping.

Longer clutch life

Clutch component parts are made of selected alloy steel and effectively heat-treated. This provides long wear resistance and long life performance.

Low maintenance

Only minimum maintenance for lubricant is required, since special heat-resistant grease is packed in. This makes maintenance easier and remarkably reduces maintenance cost.

Dust-proof construction

Combination double lip oil seal and dust protective plate keep grease in and dust out.

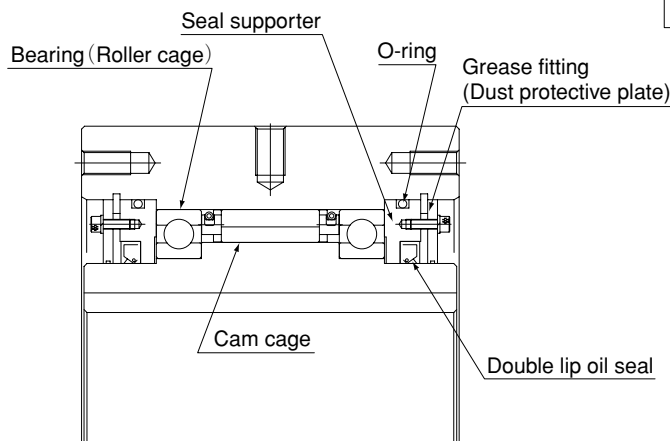

Anti-rollover cam

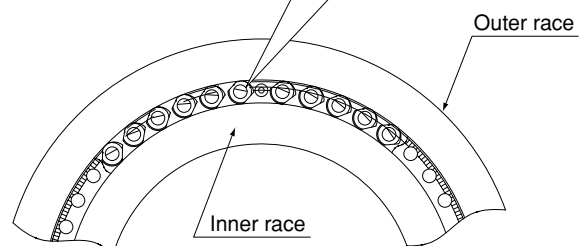
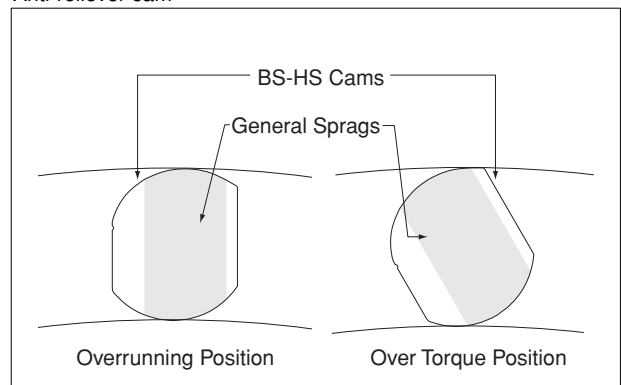

BS-HS SERIES CAM CLUTCH

Models BS160HS to BS450HS

BS160HS to BS270

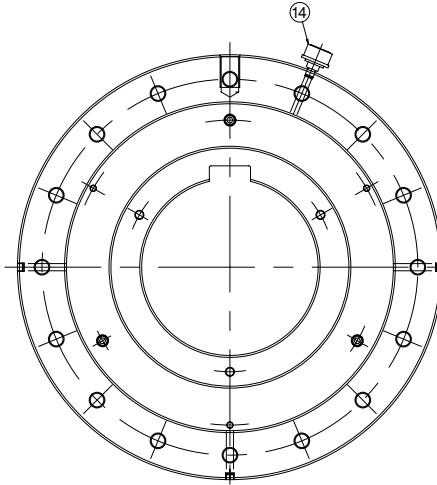
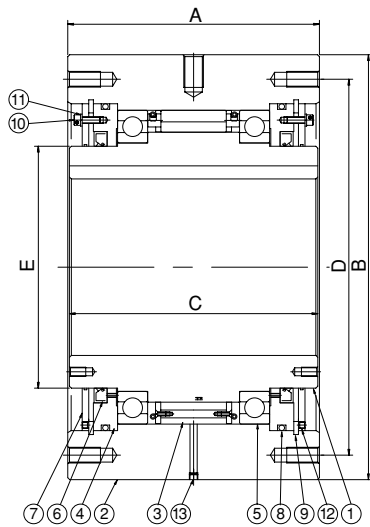

- ① Inner race
- ② Outer race
- ③ Cam cage
- ④ Seal supporter
- ⑤ Bearing
- ⑥ Oil seal
- ⑦ Grease fitting
- ⑧ O-ring
- ⑨ Snap ring
- ⑩ Socket bolt
- ⑪ Seal washer
- ⑫ Set screw
- ⑬ Socket plug
- ⑭ Air breather

BS300HS to BS350HS

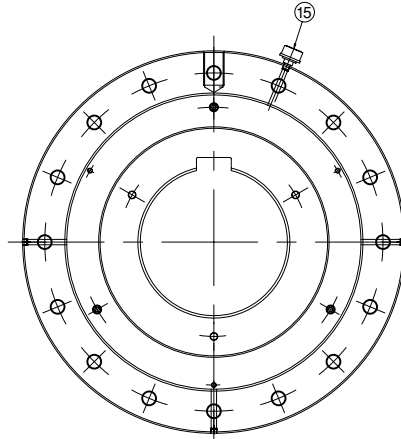
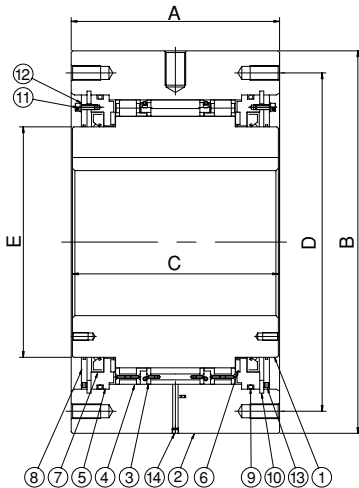

- ① Inner race
- ② Outer race
- ③ Cam cage
- ④ Roller cage
- ⑤ Seal supporter
- ⑥ Thrust bearing
- ⑦ Oil seal
- ⑧ Grease fitting
- ⑨ O-ring
- ⑩ Snap ring
- ⑪ Socket bolt
- ⑫ Seal washer
- ⑬ Set screw
- ⑭ Socket plug
- ⑮ Air breather

BS425HS to BS450HS

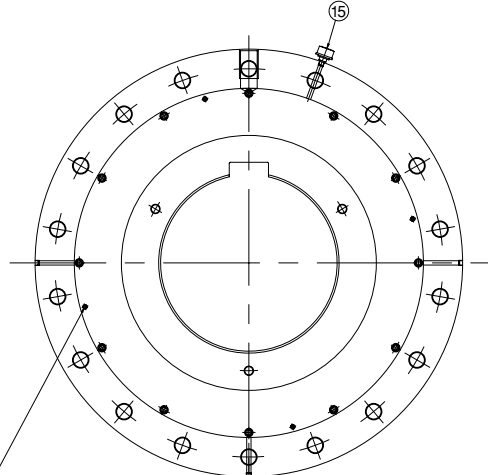
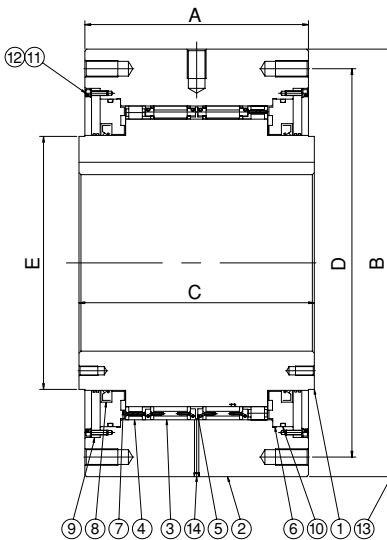

- ① Inner race
- ② Outer race
- ③ Cam cage
- ④ Roller cage
- ⑤ Spacer ring
- ⑥ Seal supporter
- ⑦ Thrust bearing
- ⑧ Oil seal
- ⑨ Grease fitting
- ⑩ O-ring
- ⑪ Socket bolt
- ⑫ Seal washer
- ⑬ Set screw
- ⑭ Socket plug
- ⑮ Air breather

Dimensions and Capacities

Model	Max. Torque N-m{kgf-m}	Bore Dia. Range (mm)	Max. Overrunning Speed Inner Race (r/min.)	Normal Overrunning Drag Torque N-m{kgf-m}	A	C	B	E	PCD D	S	H-M No. of Tapped Holes ×Size×Pitch	Q'ty of Grease (kg)	Weight (kg)
BS160HS	39,200{4,000}	100~160	350	34.3{3.5}	180	175	360	220	315	40	10×M20×P2.5	0.41	120
BS200HS	61,700{6,300}	100~200	250	44.1{4.5}	205	200	430	260	380	40	8×M22×P2.5	0.55	200
BS220HS	102,000{10,400}	150~220	200	73.5{7.5}	330	325	500	290	420	40	16×M20×P2.5	1.5	390
BS250HS	147,000{15,000}	175~250	170	93.1{9.5}	370	365	600	330	530	50	16×M24×P3.0	3.7	760
BS270HS	204,000{20,800}	200~270	160	98.0{10}	385	380	650	370	575	50	16×M24×P3.0	4.4	850
BS300HS	294,000{30,000}	230~300	150	108{11}	425	420	780	470	690	60	16×M30×P3.5	6.7	1,400
BS350HS	392,000{40,000}	250~350	110	157{16}	440	480	930	535	815	70	16×M36×P4.0	7.7	2,300
BS425HS	735,000{75,000}	325~425	85	216{22}	570	580	1,030	635	940	70	18×M36×P4.0	10	3,300
BS450HS	980,000{100,000}	350~450	80	245{25}	570	600	1,090	645	990	80	18×M42×P4.5	11	3,700

Installation and Usage

- For prevention of rotation in the reverse direction on conveyors or pumps.
- Lubrication method and dust prevention features:
Change the grease once every 6 months~12months.
Combination double lip oil seal and dust protective plate keep grease in and dust out.
- Before installation, verify that the direction of rotation of the inner race of the BS-HS Cam Clutch (shown by the arrow on the inner race) is the same as the direction of rotation of the conveyor.
- Securely install the torque arm to the BS-HS Cam Clutch using bolts of strength 10.9 or higher. Make sure that the contact between the surface of the torque arm and the side of the outer race is level and free of dust.
- Recommended shaft tolerance is h7 or h8.
- When inserting the BS-HS Cam Clutch on the shaft, apply pressure only on the inner race. Do not tap the inner race directly with a hammer or exert any force upon the outer race, dust seal, or dust plate.
- Always use a parallel key for installation onto the shaft and then fix the BS-HS Cam Clutch to the shaft with the end plate. Never use a tapered key.
- When installing cam clutches, place one of the four oil plugs in the direct bottom location. This will allow for easy drainage of the grease for cleaning.
- While the shaft is rotating, the end of the torque arm will swing to some extent in the direction of rotation. Support the torque arm end only in the direction of rotation, but be sure to allow it a certain amount of free swing. If the torque arm end is fixed securely (see installation diagram), the inside of the clutch becomes twisted, and this can result in damage to the components.
- For models BS160HS to BS200HS, a single torque arm on one side is sufficient, but for models BS220HS to BS450HS, use two torque arms, one on each side. Install the torque arms evenly so the force is transmitted through the center of the clutch.
- Torque arms for the BS Cam Clutch are options. Please inquiry to Tsubaki Emerson the dimension of torque arms.
- See "Lubrication and Maintenance" on page 6.

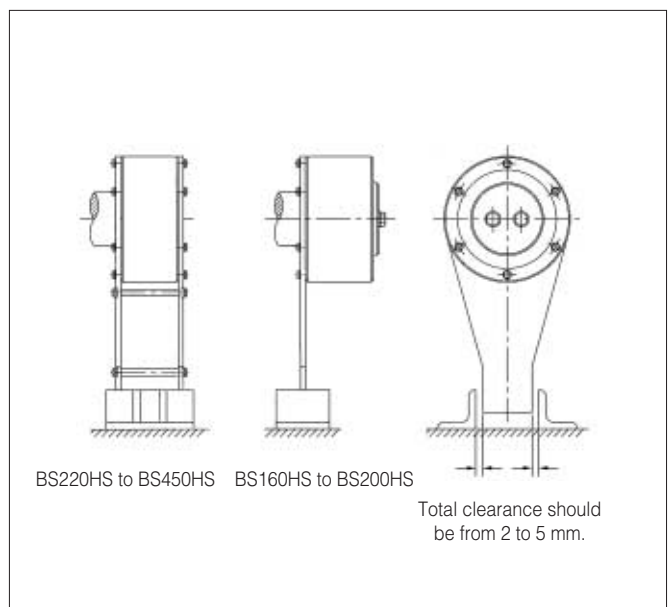
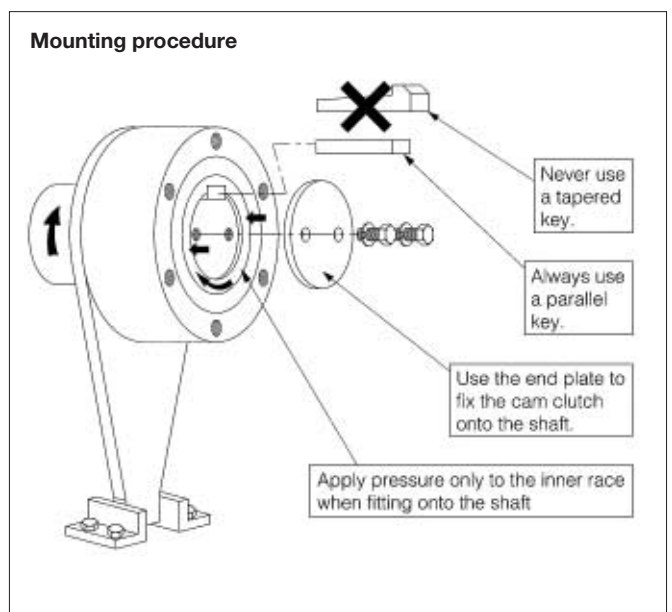

■ INFORMATION FOR SELECTION

For Belt Conveyors

Selection Procedure:

(1) Calculate the power to move an empty belt and idlers: (P_1)

$$P_1 = 0.06 \times f \times W \times V \times \frac{\ell + \ell_0}{367} \text{ (kW)}$$

(2) Calculate the power to move a loaded belt horizontally: (P_2)

$$P_2 = f \times Qt \times \frac{\ell + \ell_0}{367} \text{ (kW)}$$

(3) Calculate the power to move the load vertically: (P_3)

$$P_3 = \frac{h \times Qt}{367} \text{ (kW)}$$

(4) Calculate the back stop power: (P_r)

$$P_r = P_3 - 0.7(P_1 + P_2) \text{ (kW)}$$

(5) Calculate the back stop torque: (T)

$$T = \frac{9550 \times P_r}{N} \times SF \text{ (N·m)}$$

(6) Select the proper clutch which satisfies the calculated backstop torque.

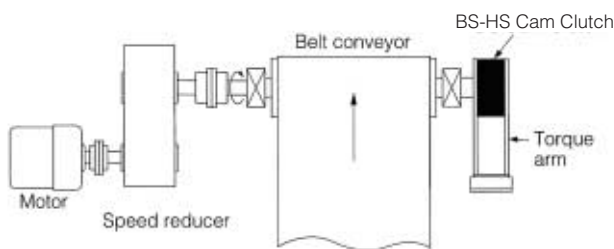

Note:

f = Friction coefficient of rollers
= 0.03 (normally used)

W = Weight of moving parts of the conveyor in the unloaded condition (kg/m)

Use the values from the table below.

Width of Belt (mm)	400	450	500	600	750	900
Estimated Weight: W	22.4	28	30	35.5	53	63
Width of Belt (mm)	1050	1200	1400	1600	1800	2000
Estimated Weight: W	80	90	112	125	150	160

V = Velocity of conveyor (m/min)

Qt = Max. possible load (tonnes/hour)

h = Total lift (m)

ℓ = Horizontal distance between head pulley and tail pulley (m)

ℓ_0 = Modification coefficient for ℓ
= 49 m (normally used)

N = Shaft speed (r/min) on which the clutch is mounted.

SF = Service factor

Select service factor from table below:

SF	Service condition
1.5	Backstopping: Several times a day
2.0	Backstopping: More than several times a day

For Bucket Elevators

Selection Procedure:

$$(1) T = \frac{9.8 \times (L + D) \times Qt \times D \times 1000}{120 \times V} \times SF \text{ (N·m)}$$

(2) Select the proper clutch which satisfies the calculated backstop torque (T).

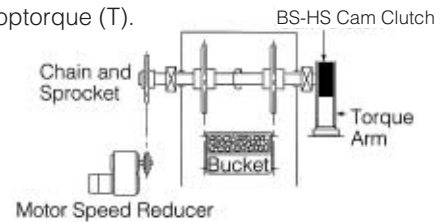

Note:

L = Total lift (m)

D = Pitch circle dia. of head sprocket (m)

Qt = Possible maximum load (tons/hour)

V = Velocity of conveyor (m/min)

SF = Service factor

Use the values from the table below.

SF	Service condition
1.5	Several times a day
2.0	More than several times a day

Note:

For the conveyor types other than those in the above examples, calculate the backstop torque accordingly.

Always allow for the maximum possible load in your calculations, since backstopping often occurs when the conveyor is loaded above its normal loading capacity.

Motor Stall Torque Method

Another method commonly used to select the proper backstop clutch size for conveyors is to use the motor name plate ratings plus the motor's ability to produce excess torque. Depending on the motor size, it may develop over 300% of rated torque. After stalling an overloaded conveyor can overload the backstop. For proper selection of the backstop, all facets of the mechanical system should be considered to ensure that the backstop is not the weakest link in the conveyor drive. If the motor breakdown torque is not known, refer to the motor manufacturer.

Selection is based on the following formula:

$$\text{Motor stall torque } T = \frac{\text{Motor name plate kW} \times 9550}{\text{Shaft speed } N \text{ (r/min)}} \times \frac{S}{100} \leq T_{\max}$$

S = Stall torque percentage

T_{\max} = Cam Clutch maximum torque at the 500,000 times point of the fatigue capacity graph (N·m)

T_{\max} = Catalogue rated torque x 1.8

or

$$\text{Motor stall torque } T = \frac{\text{Motor name plate kW} \times 9550}{\text{Shaft speed } N \text{ (r/min)}} \times SF \leq \text{catalogue max torque}$$

Depending on motor stall torque, apply the following service factors:

Stall torque	SF
Up to 180%	1.0
Up to 240%	1.3
Up to 300%	1.6

Select the Cam Clutch which satisfies the calculated torque T .

Lubrication and Maintenance

Lubricant (Grease-lubricated)

Grease is packed in the clutch before shipment.

Lubrication type : Emerlube M Manufactured by Kyodo Yushi Available from Tsubaki distributors

We are providing oil lubricated type. Please contact Tsubaki Emerson.

Maintenance

Change the grease and clean the inside of the Cam Clutch once every 6 months~12months.

See quantity of grease for each model on P4.

Note : Do not use grease that contains EP additives.

Life of Cam Clutches

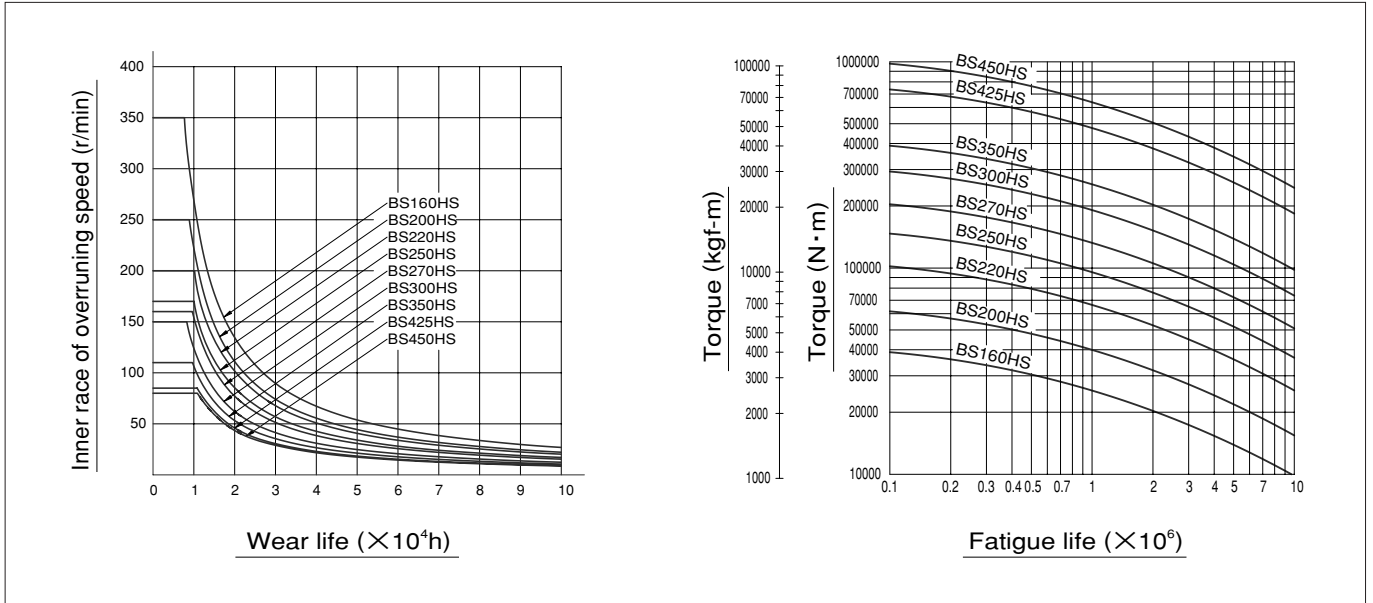

Special design versions available

Please contact Tsubaki Emerson in detail.

Double camcage model (BS160WHS~BS350WHS)

In BS425HS and BS450HS, double cam cage is
standard specification.

MA model

