

Sapphire QS-256/80 AAA

256-Channel
Inkjet Printhead

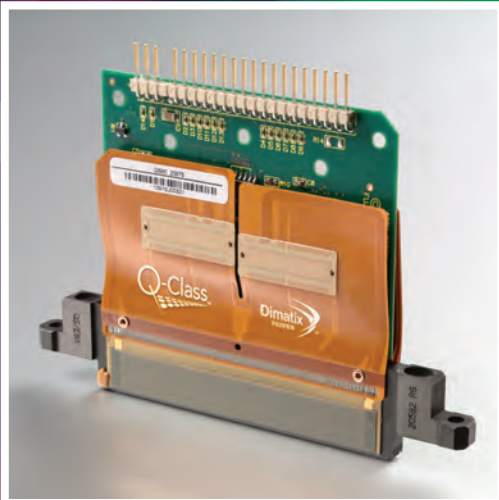

Sapphire QS-256/80 AAA

Features:

- 80 picoliter nominal drop size
- 256 individually addressable, inline nozzles
- Incorporates VersaDrop™ binary and grayscale jetting modes
- Excellent channel-to-channel uniformity
- High frequency continuous operation
- Precise alignment features facilitate drop-in replacement
- Lightweight with thin profile
- Supports UV-curable, solvent, and aqueous-based inks
- Integral temperature sensor
- Dual-ported with minimal wetted surface area
- OEM accessible non-volatile memory area for tracking purposes
- Easy to integrate

The Performa™ Sapphire QS-256/80 AAA printhead delivers best-in-class jetting accuracy combined with versatile grayscale operation. Its lightweight, thin-profile design and configurability plus support for a broad range of ink formulations makes this printhead model particularly suited to scanning printer architectures and applications.

Dimatix continues building upon its long history of excellent dot placement accuracy, channel-to-channel uniformity, low cross talk, and high-frequency/high-productivity with the Q-Class Sapphire printhead family.

The Sapphire QS-256/80 AAA printhead features 256 independent channels, arranged in a single row of nozzles at 100 dots-per-inch spacing. It is designed to eject adjustable 80 to 200 picoliter drops in binary jetting mode or a 80-picoliter fundamental drop in grayscale mode. This is done at a nominal 8-meter per second drop velocity when jetting fluids in the 10 to 14 centipoise range.

Dimatix' breakthrough VersaDrop™ jetting technology is featured within the Sapphire QS-256/80 AAA printhead. It allows unparalleled flexible modes of operation including adjustable binary drop size and grayscale capability at unprecedented throughput rates.

The rugged, field proven material set selected for the Sapphire QS-256/80 AAA printhead deliver long service life and consistent output.

Using tailored waveforms and a durable, inert silicon nozzle plate to provide best-in-class drop placement accuracy, a wide range of ink formulations are accommodated including UV-curable, organic solvent and aqueous-based inks and associated maintenance fluids.

Precision registration points have been added to the printhead to provide absolute reference to the nozzles to within a few microns. This makes it possible to nest printheads together for high packing densities.

Shared physical features and identical interfaces as other Q-Class products allow the Sapphire QS-256/80 AAA to be intermingled with the same or complementary printhead models to create a multitude of single and multiple-color configurations.

Each 256-channel Sapphire printhead is offered with an integral temperature sensor and a factory configurable, dual-ported fluid interface comprised of O-ring face mounts or barbed fittings to facilitate fast flushing or recirculation of inks.

Printhead operational temperature can be up to 90° C. The driver chip is double buffered to support the Sapphire QS-256/80 AAA high-speed jetting capability.



www.dimatix.com

Parameter

Sapphire QS-256/80 AAA

| | |
|--|---------------------------------------|
| Number of addressable jets | 256 |
| Print width | 64.77 mm [2.550 in.] |
| Nozzle spacing | 254 microns [0.010 in.] (100 dpi) |
| Typical jet straightness, 1 sigma* | 1.5 mrad [0.085°] |
| Typical drop velocity variability, 1 sigma* | 5% |
| Ink operating temperature range | up to 90° C [194° F] |
| Fluid viscosity range (at jetting temperature) | 8 - 20 cP (10 - 14 cP recommended) |
| Compatible jetting fluids | UV-curable, organic solvents, aqueous |

BINARY OPERATION:

| | |
|--------------------------|---------------------|
| Adjustment for drop size | 80 - 200 picoliters |
| Productivity | |

| Drop Size | Maximum Frequency |
|-----------|-------------------|
| 80 pl | 20 kHz |
| 200 pl | 8 kHz |

GRAYSCALE OPERATION:

| | |
|------------------------------------|-------------------------------|
| Number of levels | up to 4 |
| Fundamental drop size | 80 picoliters |
| Productivity | |
| OEM accessible non-volatile memory | Two 256-bit pages, write once |

| Largest Drop Size | Maximum Frequency |
|-------------------|-------------------|
| 200 pl | 8 kHz |

*at constant frequency

Physical Characteristics

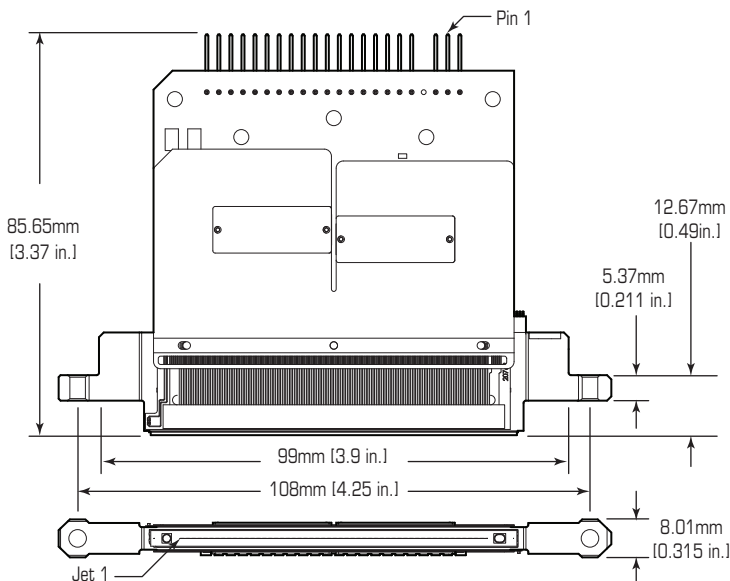

Jetting Characteristics

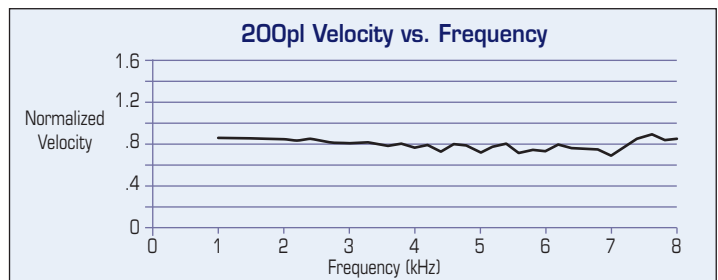
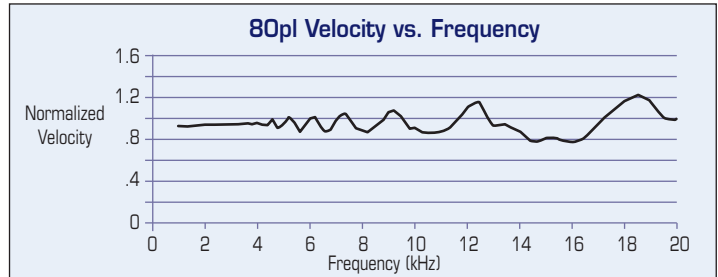

Product data presented above are for guideline purposes only. For design and engineering work using this product, please contact Dimatix Technical Support for the appropriate Product Manual containing full Product Specifications.



Corporate Office:
FUJIFILM Dimatix, Inc.
2230 Martin Avenue
Santa Clara, CA 95050
USA

Tel: (408) 565-9150
Fax: (408) 565-9151
Email: info@dimatix.com

New Hampshire Facility:
FUJIFILM Dimatix, Inc.
109 Etna Road
Lebanon, NH 03766
USA

Tel: (603) 443-5300
Fax: (603) 448-9870
Email: info@dimatix.com

Japan Office:
Advanced Marking Business Division
FUJIFILM Corporation
Midtown West, 7-3, Akasaka 9-Chome
Minato-ku, Tokyo 107-0002
Japan

Tel: +81 3 6271 1091
Fax: +81 3 6271 1165
E-mail: front.ambd@fujifilm.co.jp

European Office:
Tel: +44 7739 863 505
Fax: +44 870 167 4328
Email: euro@dimatix.com

Korean Office:
Tel: +82 2 6242 6012
Fax: +82 2 6247 6012
Email: korea@dimatix.com

China Office:
Email: china@dimatix.com