

HMWTECH CO.,LTD

Low noise linear module

W Series

Linear Modules



Specification	Max Load	Guide Width	Pitch	Torque	Positional Repeatability
W40-03	3 KG	40MM	75MM	≤ 3 N.M	≤ 0.05 MM
W40-10	10 KG	40MM	75MM	≤ 3 N.M	≤ 0.05 MM
W45-15	15 KG	45MM	80MM	≤ 4.5 N.M	≤ 0.05 MM
W50-25	25 KG	50MM	95MM	≤ 6.5 N.M	≤ 0.05 MM
W60-35	35 KG	60MM	95MM	≤ 8.5 N.M	≤ 0.05 MM
W45A-05	5 KG	45MM	75MM	≤ 3 N.M	≤ 0.05 MM
W35	3KG	35MM	63MM	≤ 3 N.M	≤ 0.05 MM
W100	30 KG	100MM	125MM	≤ 8.5 N.M	≤ 0.05 MM

WH Series

Linear Modules

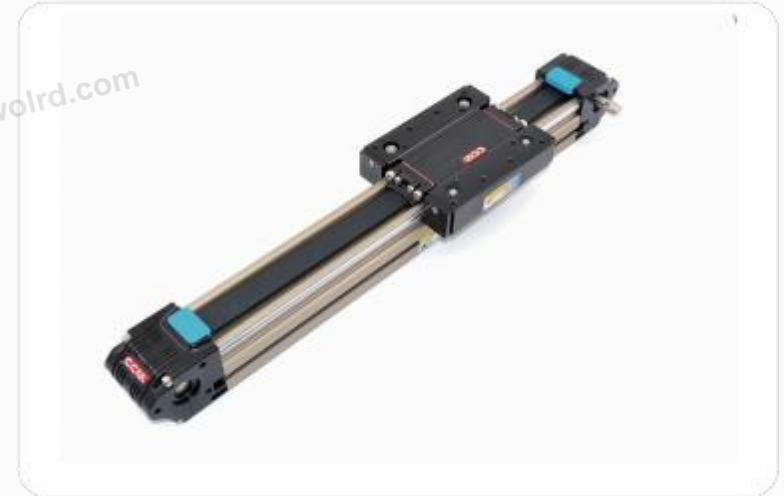

Specification	Max Load	Guide Width	Pitch	Torque	Positional Repeatability
WH35	3 KG	35 MM	63 MM	≤ 1 N.M	≤ 0.1 MM
WH100	30 KG	100 MM	125 MM	≤ 4.5 N.M	≤ 0.1 MM

Website: <https://www.himcnc.com>

Get-a-Quote email: info@harmonyworld.com

H Series

Linear Modules



Specification	Max Load	Guide Width	Pitch	Torque	Positional Repeatability
H45-20	20 KG	45 MM	80 MM	≤ 3 N.M	≤ 0.05 MM
H60-40	40 KG	60 MM	95 MM	≤ 8.5 N.M	≤ 0.05 MM
H80-50	50 KG	80 MM	190 MM	≤ 13.5 N.M	≤ 0.05 MM

L Series

Synchronized Belt Extended Slider Module



Specification	Max Load	Guide Width	Pitch	Torque	Positional Repeatability
L45-15	15 KG	45 MM	80MM	≤ 3 N.M	≤ 0.05 MM
L50-25	25 KG	50 MM	95MM	≤ 6.5 N.M	≤ 0.05 MM
L60-35	35 KG	60 MM	110MM	≤ 8.5 N.M	≤ 0.05 MM
L80-60	60 KG	80 MM	190MM	≤ 13.5N.M	≤ 0.05 MM

Z Series

Self-propelled series



Specification	Max Load	Guide Width	Pitch	Torque	Positional Repeatability
Z45-15	15 KG	45 MM	110 MM	≤ 3.0N.M	≤ 0.05 MM
Z50-20	20 KG	50 MM	110 MM	≤ 6.5N.M	≤ 0.05 MM
Z60-30	30 KG	60 MM	110 MM	≤ 6.5N.M	≤ 0.05 MM
Z80-50	50 KG	80 MM	190 MM	≤ 13.5N.M	≤ 0.05 MM

Q Series



Specification	length	Rated Stroke	Pitch	Linear Accuracy	Rated Load	torque
Q45	360 MM	100 MM	80 MM	0.05 MM	15 KG	≤3.5 N.M
	460 MM	200 MM	80 MM	0.05 MM	15 KG	≤3.5 N.M
	80 MM	0.05 MM	15 KG	≤3.5 N.M
	1960 MM	1700 MM	80 MM	0.05 MM	15 KG	≤3.5 N.M

Customizable itinerary: every 100mm increment, 100-1700mm

Specification	length	Rated Stroke	Pitch	Linear Accuracy	Rated Load	torque
Q60	400 MM	100 MM	95 MM	0.05 MM	35 KG	≤ 8.5 N.M
	500 MM	200 MM	95 MM	0.05 MM	35 KG	≤ 8.5 N.M
	95 MM	0.05 MM	35 KG	≤ 8.5 N.M
	2000 MM	1700 MM	95 MM	0.05 MM	35 KG	≤ 8.5 N.M

SW35 SW Series

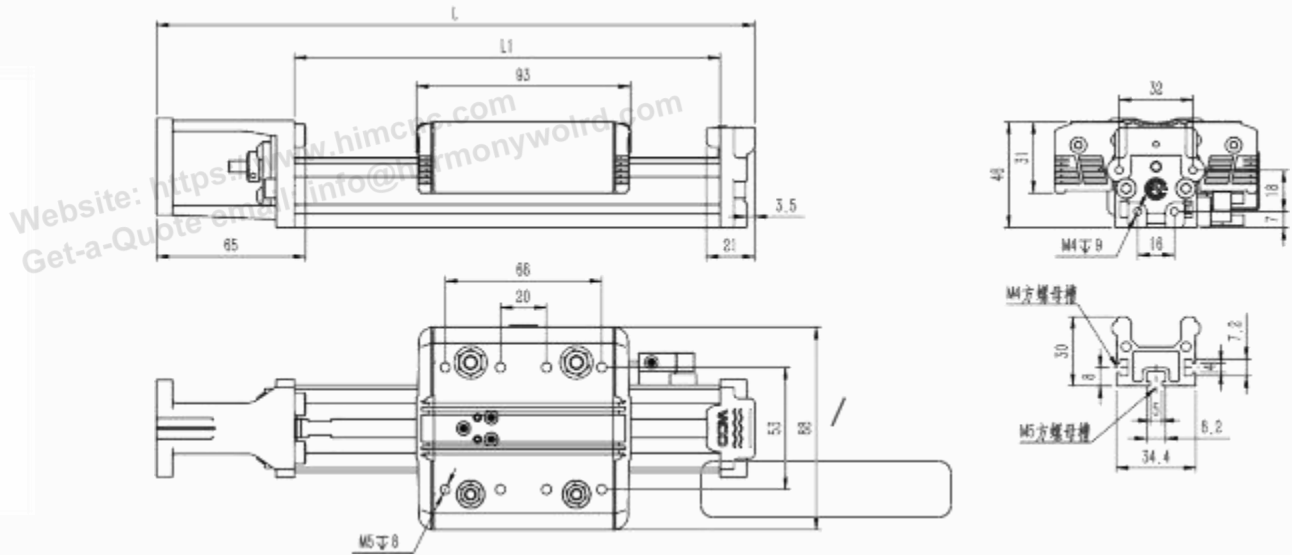
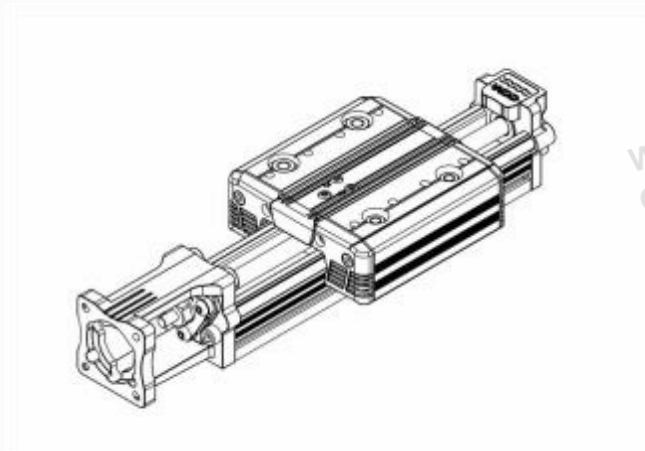

Specification	length		Rated Stroke	Actual Stroke	Pitch	Linear Accuracy	Rated Load	Applicable Load	Torque	Applicable Motor
	L	L1								
SW35-50	260 MM	185 MM	50 MM	81 MM	2.5 MM	0.02 MM	5 KG	0-3 KG	≤ 1 N.M	Nema17 Stepper Motor Nema23 Stepper Motor 100W Servo Motor
SW35-100	310 MM	235 MM	100 MM	131 MM	2.5 MM	0.02 MM	5 KG	0-3 KG	≤ 1 N.M	
SW35-150	360 MM	285 MM	150 MM	181 MM	2.5 MM	0.02 MM	5 KG	0-3 KG	≤ 1 N.M	
SW35-200	410 MM	335 MM	200 MM	231 MM	2.5 MM	0.02 MM	5 KG	0-3 KG	≤ 1 N.M	
SW35-250	460 MM	385 MM	250 MM	281 MM	2.5 MM	0.02 MM	5 KG	0-3 KG	≤ 1 N.M	
SW35-300	510 MM	435 MM	300 MM	331 MM	2.5 MM	0.02 MM	5 KG	0-3 KG	≤ 1 N.M	

SH35 SH Series

Sliding module

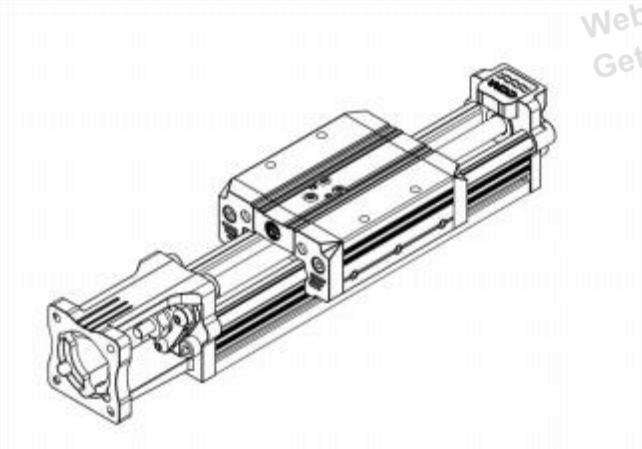

Website: <https://www.himcnc.com>
 Get-a-Quote email: info@harmonywolrd.com

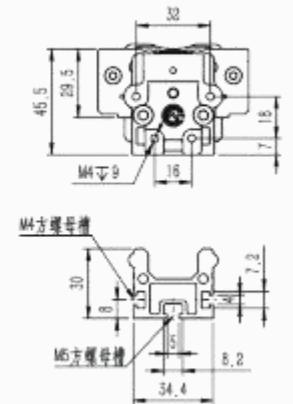
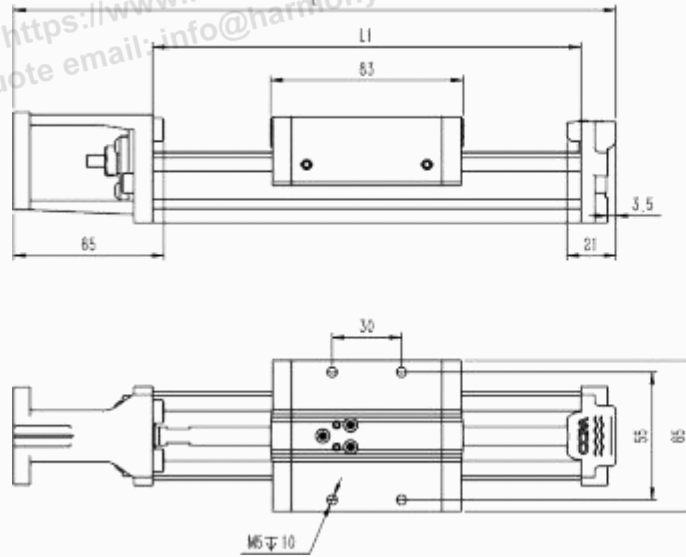

Specification	length		Rated Stroke	Actual Stroke	Pitch	Linear Accuracy	Rated Load	Applicable Load	Torque	Applicable Motor
	L	L1								
SH35-50	260 MM	185 MM	50 MM	91 MM	2.5 MM	0.02 MM	5 KG	0-3 KG	≤ 1 N.M	Nema17 Stepper Motor Nema23 Stepper Motor 100W Servo Motor
SH35-100	310 MM	235 MM	100 MM	141 MM	2.5 MM	0.02 MM	5 KG	0-3 KG	≤ 1 N.M	
SH35-150	360 MM	285 MM	150 MM	191 MM	2.5 MM	0.02 MM	5 KG	0-3 KG	≤ 1 N.M	
SH35-200	410 MM	335 MM	200 MM	241 MM	2.5 MM	0.02 MM	5 KG	0-3 KG	≤ 1 N.M	
SH35-250	460 MM	385 MM	250 MM	291 MM	2.5 MM	0.02 MM	5 KG	0-3 KG	≤ 1 N.M	
SH35-300	510 MM	435 MM	300 MM	341 MM	2.5 MM	0.02 MM	5 KG	0-3 KG	≤ 1 N.M	

TX 40 Push rod

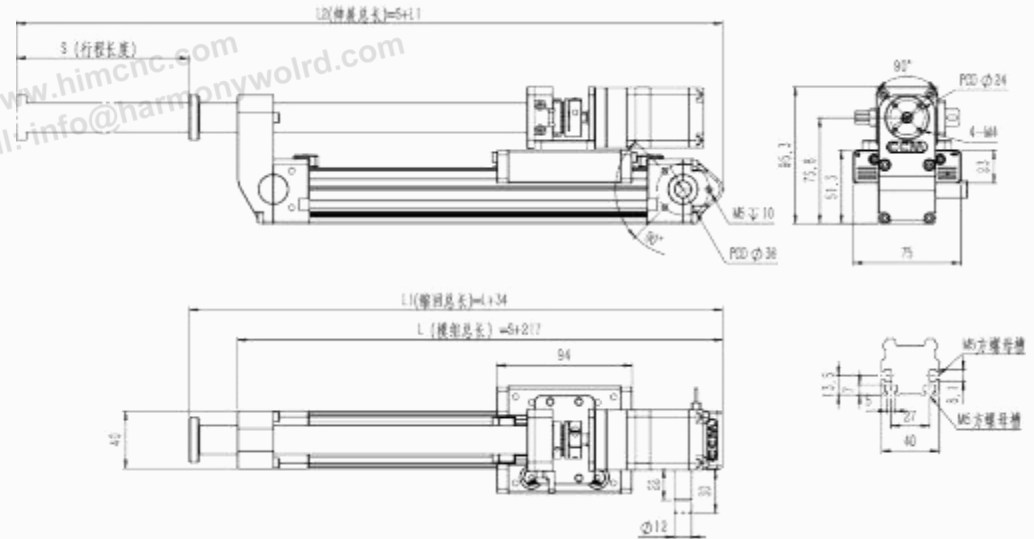

Specification	length	weight	Rated Stroke	Pitch	Linear Accuracy	Rated Load	Applicable Load	Torque	Applicable Motor
TX40-70	320 MM	2.29 KG	70 MM	75 MM	0.05 MM	5 KG	0-3 KG	≤3.5 N.M	Nema23 Stepper Motor 60 Servo Motor
TX40-120	370 MM	2.43 KG	120 MM	75 MM	0.05 MM	5 KG	0-3 KG	≤3.5 N.M	
TX40-170	420 MM	2.57 KG	170 MM	75 MM	0.05 MM	5 KG	0-3 KG	≤3.5 N.M	
TX40-220	470 MM	2.71 KG	220 MM	75 MM	0.05 MM	5 KG	0-3 KG	≤3.5 N.M	
TX40-270	520 MM	2.85 KG	270 MM	75 MM	0.05 MM	5 KG	0-3 KG	≤3.5 N.M	
TX40-320	570 MM	3 KG	320 MM	75 MM	0.05 MM	5 KG	0-3 KG	≤3.5 N.M	

TX 40 pull-push rod

Cylinder

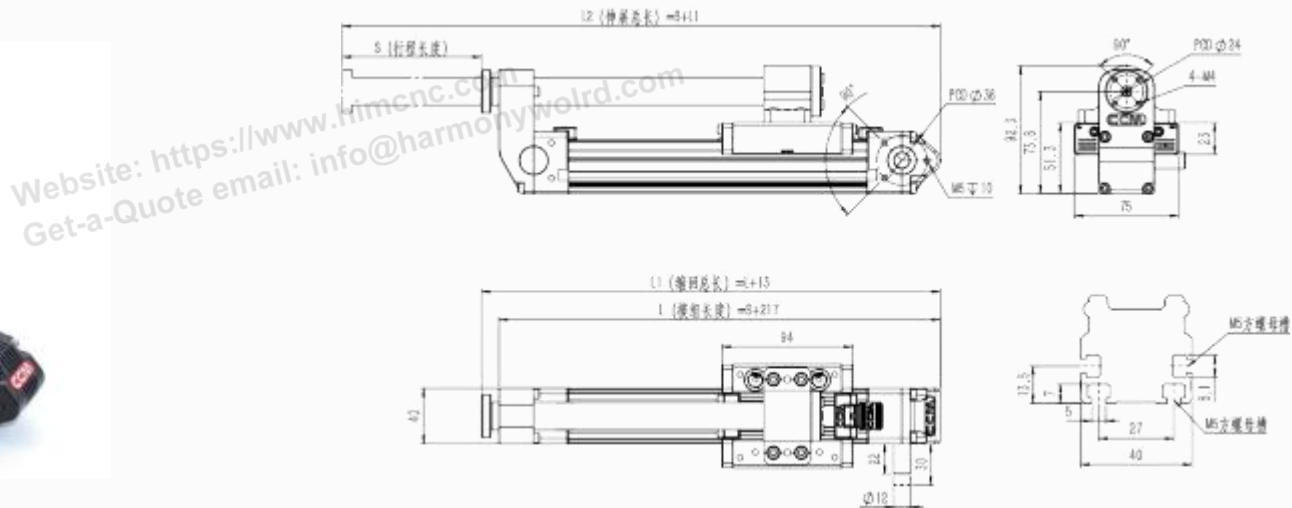

Specification	length	weight	Rated Stroke	Pitch	Linear Accuracy	Rated Load	Applicable Load	Torque	Applicable Motor
T40-50	282 MM	1.71 KG	50 MM	75 MM	0.05 MM	5 KG	0-3 KG	≤3.5 N.M	Nema23 Stepper Motor 60 Servo Motor
T40-100	332 MM	1.85 KG	100 MM	75 MM	0.05 MM	5 KG	0-3 KG	≤3.5 N.M	
T40-150	382 MM	2 KG	150 MM	75 MM	0.05 MM	5 KG	0-3 KG	≤3.5 N.M	
T40-200	432 MM	2.14 KG	200 MM	75 MM	0.05 MM	5 KG	0-3 KG	≤3.5 N.M	
T40-250	482 MM	2.28 KG	250 MM	75 MM	0.05 MM	5 KG	0-3 KG	≤3.5 N.M	
T40-300	532 MM	2.42 KG	300 MM	75 MM	0.05 MM	5 KG	0-3 KG	≤3.5 N.M	

Naming Rules

HM - W40 - 10 - L1000 - DC - 1A - 60(D14)

1

2

3

4

5

6

- 1 Brand、 Model : CCM-W40-10 / W45-15 / W50-25 ...
- 2 Total length : L1000 (Total length 1000mm); GL1000 (Rail length 1000mm); S1000 (Stroke length 1000mm) Length relationship refers to "Module Length Indication" on the right.
- 3 Motor Connections : DC (Direct connection); DG (Connect by speed reducer set); More details, please see the illustration.
- 4 Shaft position : 1~8 (Shaft Position); A~D (Motor Position); More details, please see the illustration.
- 5 Dimension of Motor/Planetary Gearbox
- 6 Shaft Diameter of Motor/Planetary Gearbox

Note: If you need rail mount,sensor, motor, planetary gearbox and other accessory, please contact us to order.

A

Part Length Indication >>

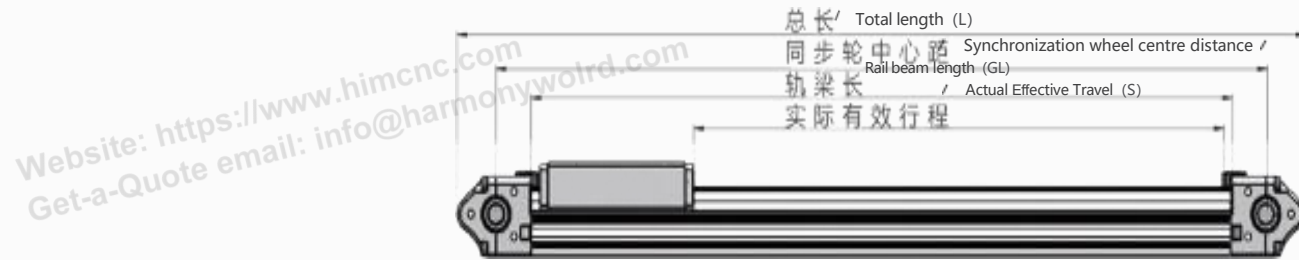

B

Motor Connections >>

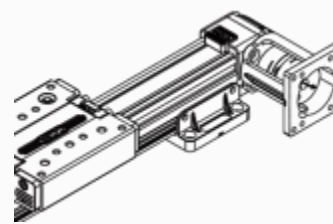

Motor Bracket

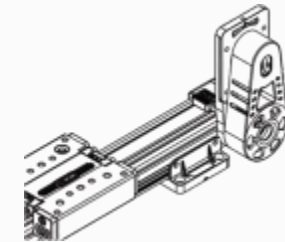

Speed Reducer Set

C

Motor Shaft position >>

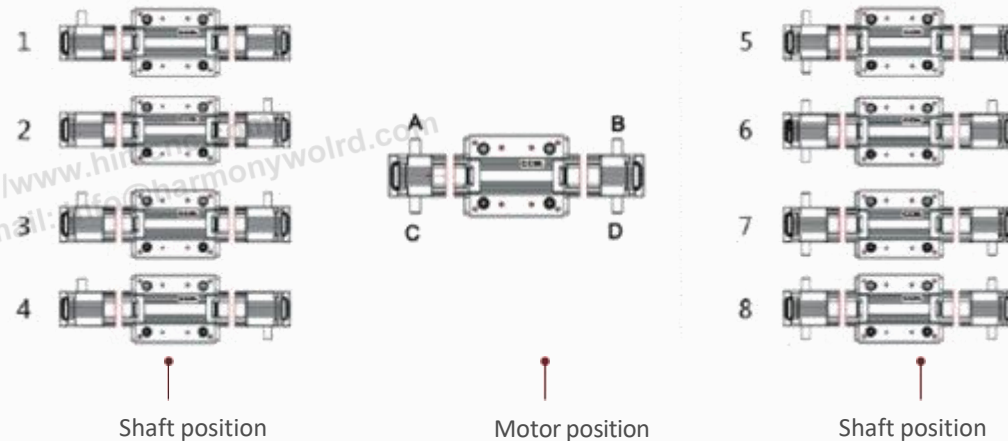

W40-03

W Series

■ Dimensions (Unit : mm)

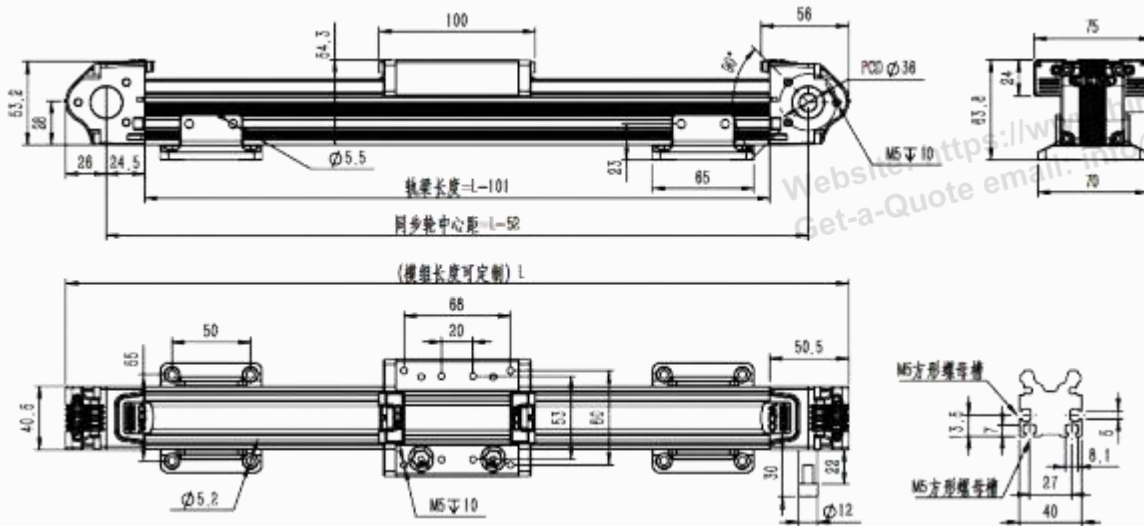

(Suggested length=Effective stroke+230MM)

- Model : W40-03
 - Guide Width : 40 MM
 - Max Load : 3 KG
 - Pitch : 75 MM
 - Straightness : 0.05 / 300 MM
 - Recommended speed : ≤ 1.5 M/s
 - Input Torque : ≤ 3 N.M
- Customized Length : Up to 4 meters *50MM, 1000MM, 1050MM、 1100MM...
 Length of 50mm increase and decrease, such as 1000mm, 1050mm, 1100mm...
 Belt Spec. : PU-3M-15(STD)
 Synchronous Wheel Spec. : HTD3M-25Z
 Applicable Motor and Mounting Way
 I. Stepper Motor: Nema 17 (Direct Connection) ; Nema 23 (DC/Speed Reducer Set)
 II. Servo Motor: 100W (Direct Connection) ; 200W/400W (DC/Speed Reducer Set)



Model	W40-03	
Carriage Parameter	Fx max (N)	100
	Fy max (N)	370
	Fz max (N)	429
	Mx max (N.M)	8.1
	My max (N.M)	9.6
	Mz max (N.M)	4.2
$(\text{Max Load}) = \frac{F_y}{F_{y\max}} + \frac{F_z}{F_{z\max}} + \frac{M_x}{M_{x\max}} + \frac{M_y}{M_{y\max}} + \frac{M_z}{M_{z\max}} \leq 1$		
The maximum load coefficient is the coefficient of the linear module's operating life of 10000KM, which is the final basis for linear module selection. (It needs to consider the force and torque generated by acceleration in single or multiple-axis)		

W40-10

W Series

■ Dimensions (Unit : mm)

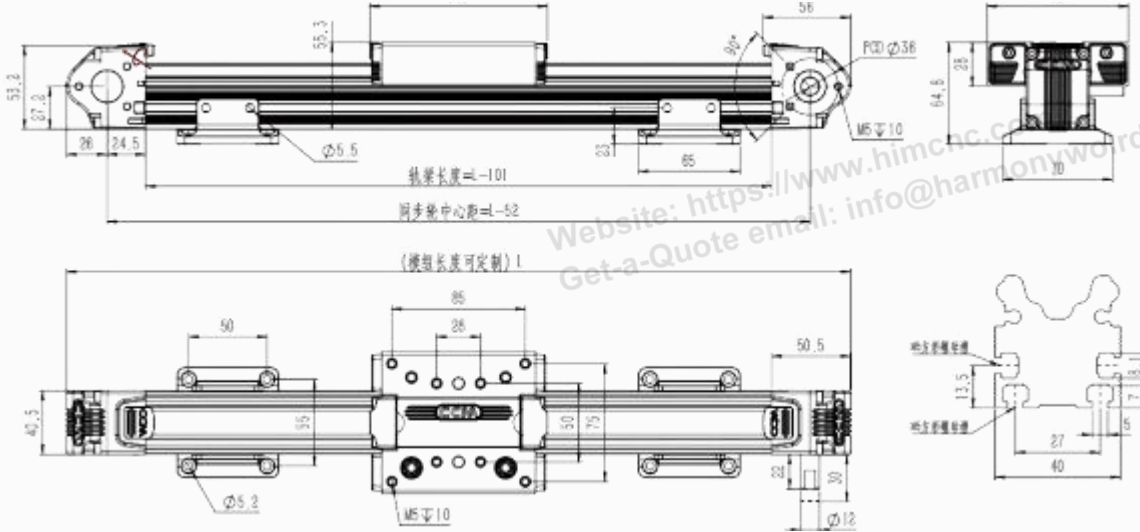

(Suggested length=Effective stroke+250MM)

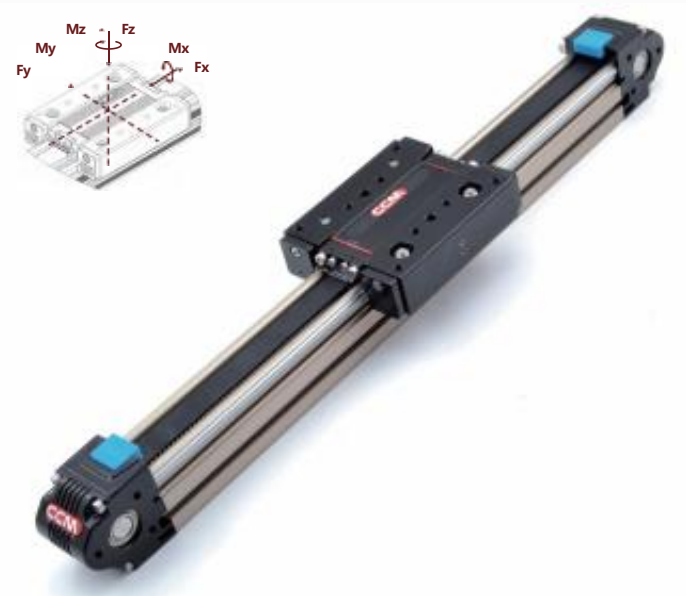

- Model : W40-10
- Guide Width : 40 MM
- Max Load : 10 KG
- Pitch : 75 MM
- Straightness : 0.05 / 300 MM
- Recommended speed : ≤ 1.5 M/s
- Input Torque : ≤ 3 N.M
- Customized Length : Up to 4 meters 50MM 100MM、1050MM、1100MM...
Length of 50mm increase and decrease, such as 1000mm, 1050mm, 1100mm...
- Belt Spec. : PU-3M-15(STD)
- Synchronous Wheel Spec. : HTD3M-25Z
- Applicable Motor and Mounting Way
 - I. Stepper Motor: Nema 17 (Direct Connection) ; Nema 23 (DC/Speed Reducer Set)
 - II. Servo Motor: 100W (Direct Connection) ; 200W/400W (DC/Speed Reducer Set)

Model		W40-10
Carriage Parameter	Fx max (N)	100
	Fy max (N)	655
	Fz max (N)	762
	Mx max (N.M)	14.5
	My max (N.M)	22.8
	Mz max (N.M)	9.8
$(\text{Max. Load}) = \frac{F_y}{F_{y\max}} + \frac{F_z}{F_{z\max}} + \frac{M_x}{M_{x\max}} + \frac{M_y}{M_{y\max}} + \frac{M_z}{M_{z\max}} \leq 1$		
• The maximum load coefficient is the coefficient of the linear module's operating life of 10000KM, which is the final basis for linear module selection. (It needs to consider the force and torque generated by acceleration in single or multiple-axis)		

W 45 - 15

W Series

■ Dimensions (Unit : mm)

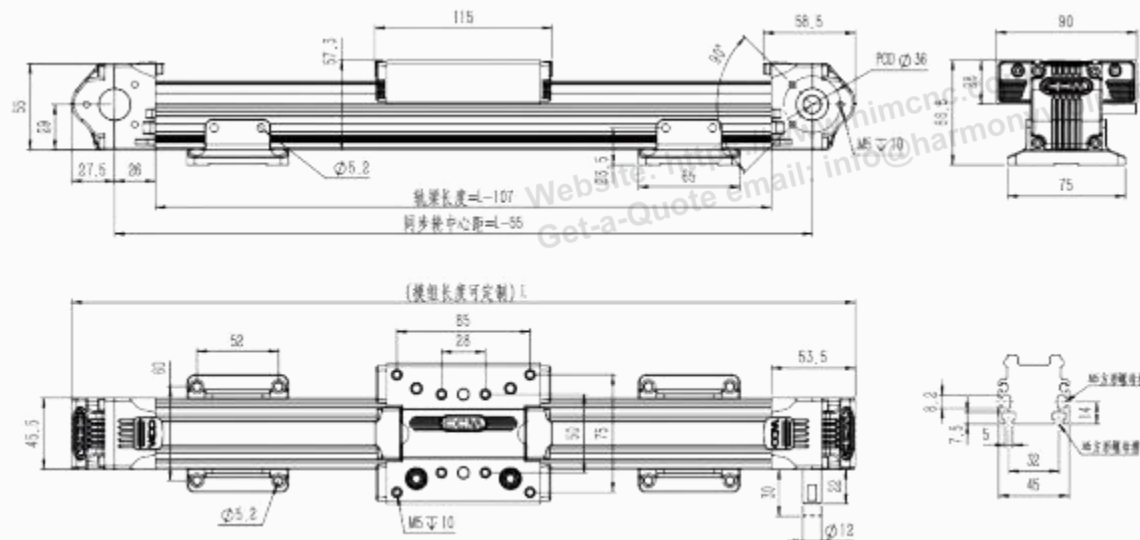

(Suggested length=Effective stroke+250MM)



- Model : W45-15
- Guide Width : 45 MM
- Max Load : 15 KG
- Pitch : 80 MM
- Straightness : 0.05 / 300 MM
- Recommended speed : ≤ 1.5 M/s
- Input Torque : ≤3 N.M
- Customized Length : Up to 6 meters * 50MM 1000MM、1050MM、1100MM...
Length of 50mm increase and decrease, such as 1000mm, 1050mm, 1100mm...
- Belt Spec. : PU-5M-15(/Stainless Steel)
- Synchronous Wheel Spec. : STD5M-16Z
- Applicable Motor and Mounting Way
I. Stepper Motor: Nema 17 (Direct Connection) ; Nema 23 (DC/Speed Reducer Set)

Model		W45 - 15
Carriage Parameter	Fx max (N)	200
	Fy max (N)	655
	Fz max (N)	762
	Mx max (N.M)	14.5
	My max (N.M)	22.8
	Mz max (N.M)	9.8
$(\text{Max. Load}) = \frac{F_y}{F_{y\max}} + \frac{F_z}{F_{z\max}} + \frac{M_x}{M_{x\max}} + \frac{M_y}{M_{y\max}} + \frac{M_z}{M_{z\max}} \leq 1$		
<p>*The maximum load coefficient is the coefficient of the linear module's operating life of 10000KM, which is the final basis for linear module selection. (It needs to consider the force and torque generated by acceleration in single or multiple-axis)</p>		

W50 - 25

W Series

■ Dimensions (Unit : mm)

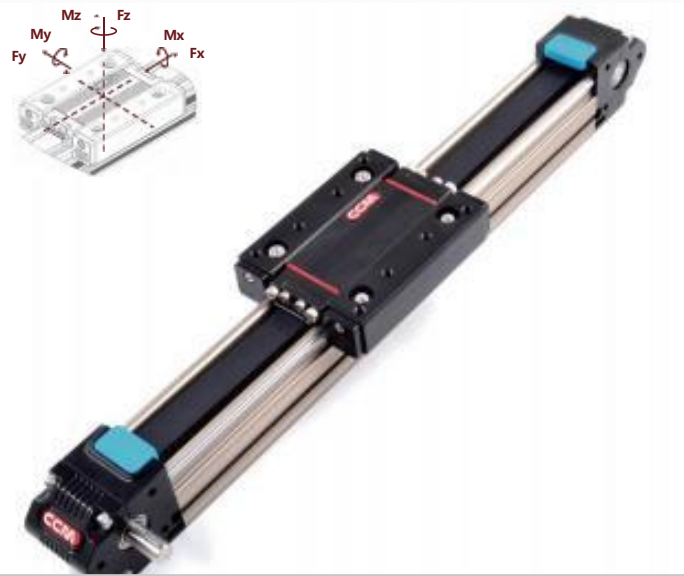
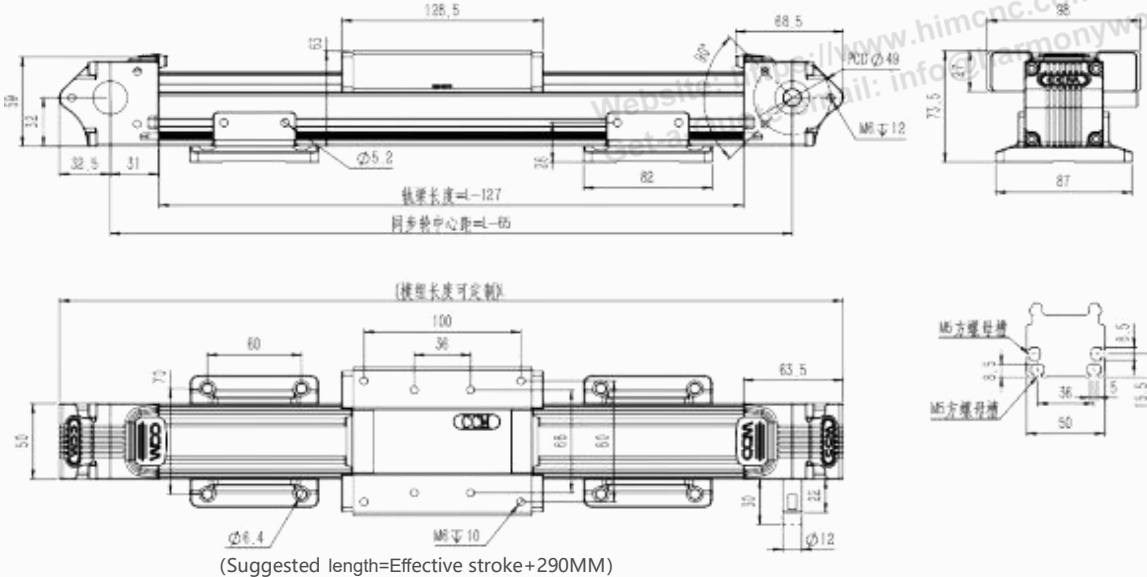

- Model : W50-25
- Guide Width : 50 MM
- Max Load : 25 KG
- Pitch : 95 MM
- Straightness : 0.05 / 300 MM
- Recommended speed : ≤ 2 M/s
- Input Torque : ≤ 6.5 N.M
- Customized Length : Up to 6 meters *50MM 1000MM、1050MM、1100MM...
Length of 50mm increase and decrease, such as 1000mm, 1050mm, 1100mm...
- Belt Spec : PU-5M-20(STD)
- Synchronous Wheel Spec. : STD5M-19Z
- Applicable Motor and Mounting Way
I. Stepper Motor: Nema 23 (Direct Connection/Speed Reducer Set)
; Nema 34 (DC/Speed Reducer Set)
II. Servo Motor: 750W (Direct Connection)
; 200W/400W (DC/Speed Reducer Set)

Model	W50-25	
Carriage Parameter	Fx max (N)	500
	Fy max (N)	655
	Fz max (N)	762
	Mx max (N.M)	17.5
	My max (N.M)	30.5
	Mz max (N.M)	13.1

$$(Max. Load) = \frac{Fy}{Fy_{max}} + \frac{Fz}{Fz_{max}} + \frac{Mx}{Mx_{max}} + \frac{My}{My_{max}} + \frac{Mz}{Mz_{max}} \leq 1$$

• The maximum load coefficient is the coefficient of the linear module's operating life of 10000KM, which is the final basis for linear module selection. (It needs to consider the force and torque generated by acceleration in single or multiple-axis)

W60 - 35

W Series

■ Dimensions (Unit : mm)

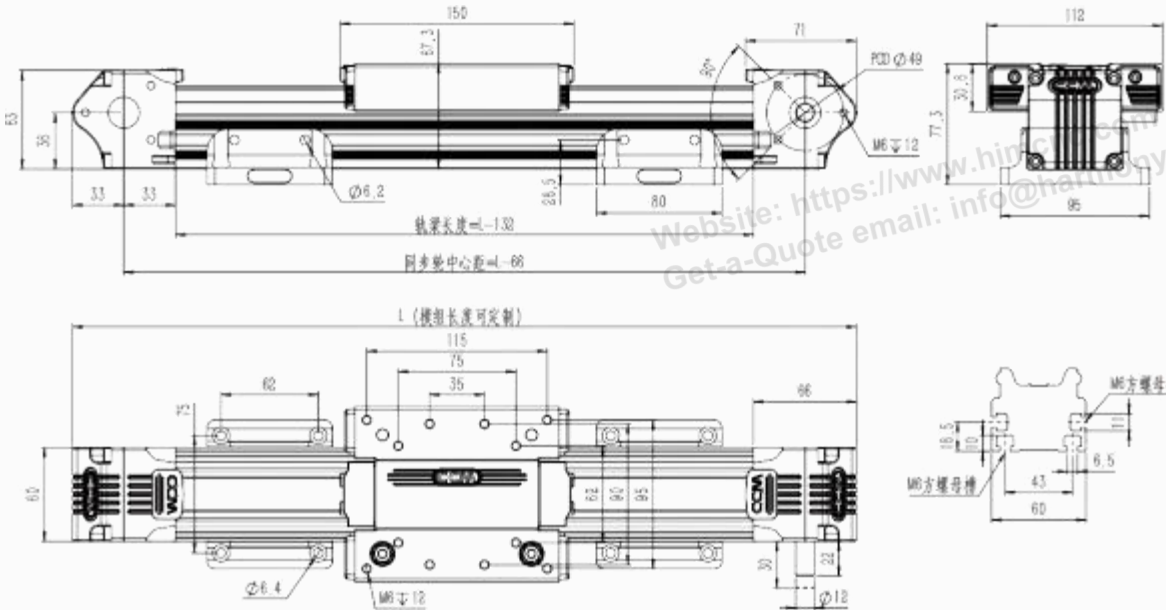

(Suggested length=Effective stroke+310MM)

- Model : W60-35
 - Guide Width : 60 MM
 - Max Load : 35 KG
 - Pitch : 95 MM
 - Straightness : 0.05 / 300 MM
 - Recommended speed : ≤ 2 M/s
 - Input Torque : ≤8.5 N.M
 - Customized Length : Up to 6 meters * 50MM 1000MM、1050MM、1100MM...
Length of 50mm increase and decrease, such as 1000mm, 1050mm, 1100mm...
 - Belt Spec. : PU-5M-20(STD)
 - Synchronous Wheel Spec. : STD5M-19Z
- Applicable Motor and Mounting Way
 I. Stepper motor: 57 steps (direct connection/wheel reduction); 86 steps (direct connection/wheel reduction)II. Servo Motor: 750W (Direct Connection) ; 200W/400W (DC/Speed Reducer Set)

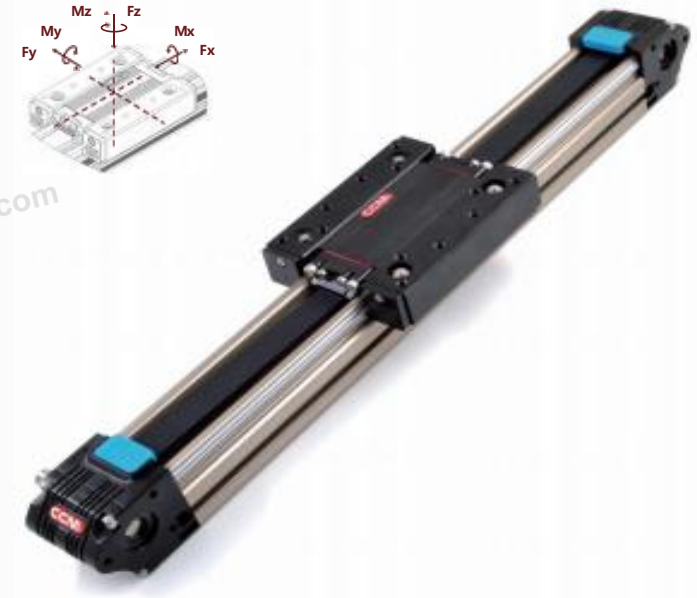
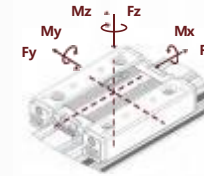

Model	W60 - 35	
Carriage Parameter	Fx max (N)	515
	Fy max (N)	1001
	Fz max (N)	1164
	Mx max (N.M)	32.6
	My max (N.M)	55.3
	Mz max (N.M)	23.8
$(\text{Max. Load}) = \frac{F_y}{F_{y\max}} + \frac{F_z}{F_{z\max}} + \frac{M_x}{M_{x\max}} + \frac{M_y}{M_{y\max}} + \frac{M_z}{M_{z\max}} \leq 1$		
• The maximum load coefficient is the coefficient of the linear module's operating life of 10000KM, which is the final basis for linear module selection. (It needs to consider the force and torque generated by acceleration in single or multiple-axis)		

W45A - 05

W Series

■ Dimensions (Unit : mm)

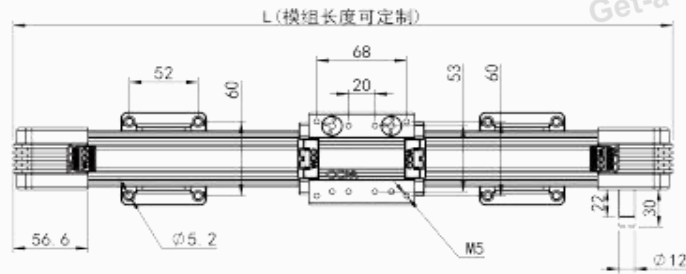
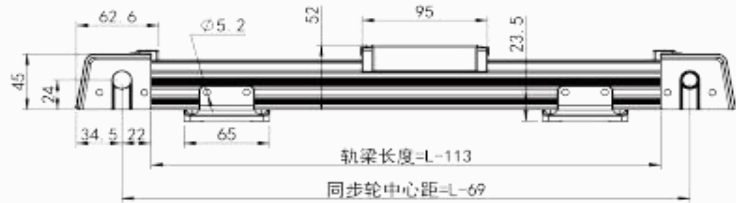

(Suggested length=Effective stroke+290MM)

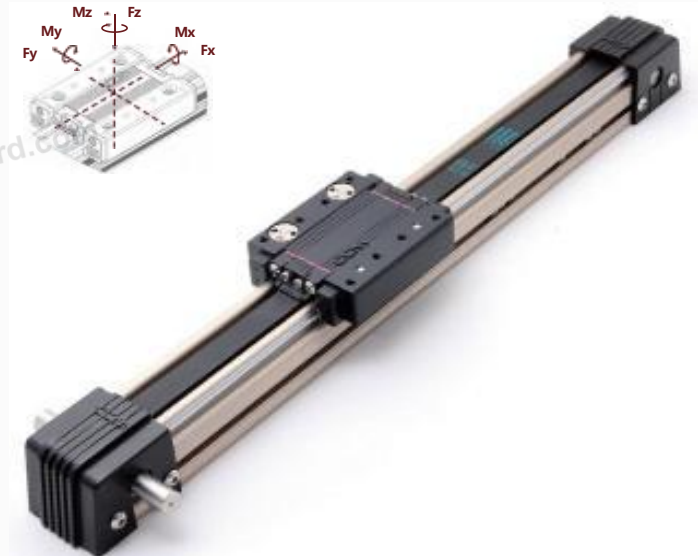
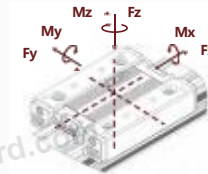
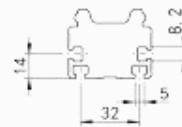
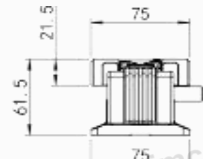

- Model : W45A-05
- Guide Width : 45 MM
- Max Load : 5 KG
- Pitch : 75 MM
- Straightness : 0.05 / 300 MM
- Recommended speed : ≤ 1 M/s
- Input Torque : ≤ 3 N.M
- Customized Length : Up to 4 meters *50MM, 1000MM、1050MM、1100MM...
Length of 50mm increase and decrease, such as 1000mm, 1050mm, 1100mm...
- Belt Spec. : PU-3M-15(STD)
- Synchronous Wheel Spec. : HTD3M-25Z
- Applicable Motor and Mounting Way
 - I. Stepper Motor: Nema 17 (Direct Connection) ; Nema 23 (DC/Speed Reducer Set)
 - II. Servo Motor: 100W (Direct Connection) ; 200W/400W (DC/Speed Reducer Set)

Model	W45A-05	
Carriage Parameter	Fx max (N)	100
	Fy max (N)	370
	Fz max (N)	429
	Mx max (N.M)	8.1
	My max (N.M)	9.6
	Mz max (N.M)	4.2
$(\text{Max. Load}) = \frac{F_y}{F_{y\max}} + \frac{F_z}{F_{z\max}} + \frac{M_x}{M_{x\max}} + \frac{M_y}{M_{y\max}} + \frac{M_z}{M_{z\max}} \leq 1$		
<p>• The maximum load coefficient is the coefficient of the linear module's operating life of 10000KM, which is the final basis for linear module selection. (It needs to consider the force and torque generated by acceleration in single or multiple-axis)</p>		

W35

W Series

■ Dimensions (Unit : mm)

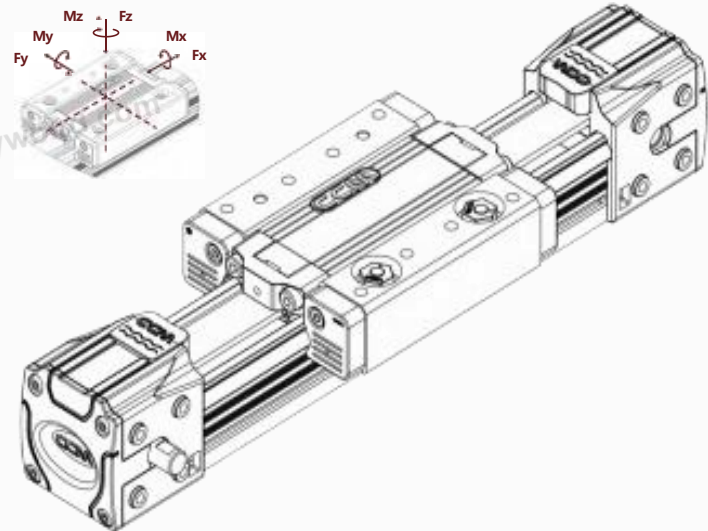
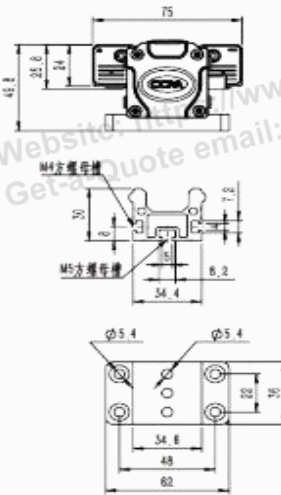
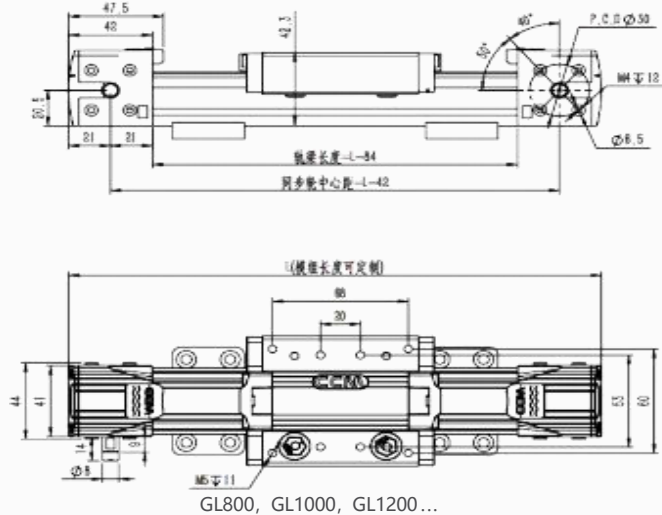

- Model : W35
- Guide Width : 35 MM
- Max Load : 3 KG
- Pitch : 63 MM
- Straightness : 0.03 / 300 MM
- Recommended speed : ≤ 0.8 M/s
- Input Torque : ≤0.8 N.M
- Customized Length : Up to 1.5 meters * 100MM
1000MM、1100MM、1200MM...
Length of 50mm increaseand decrease, such as 1000mm, 1050mm, 1100mm...
- Belt Spec. : PU-3M-15(/Stainless Steel)
- Synchronous Wheel Spec. : HTD3M-21Z
- Applicable Motor and Mounting Way
I. Stepper Motor: Nema 17 (Direct Connection) ; Nema 23 (DC)
II..Servo Motor: 100W (Direct Connection)

Model	W35	
Carriage Parameter	Fx max (N)	90
	Fy max (N)	180
	Fz max (N)	210
	Mx max (N.M)	4
	My max (N.M)	4.8
	Mz max (N.M)	2.1
$(\text{Max Load}) = \frac{Fy}{Fy_{\text{max}}} + \frac{Fz}{Fz_{\text{max}}} + \frac{Mx}{Mx_{\text{max}}} + \frac{My}{My_{\text{max}}} + \frac{Mz}{Mz_{\text{max}}} \leq 1$		
• The maximum load coefficient is the coefficient of the linear module's operating life of 10000KM,which is the final basis for linear moduleselection.(It needs to consider the force and torque generated by acceleration in single or multiple-axis)		

W100

W Series

■ Dimensions (Unit : mm)

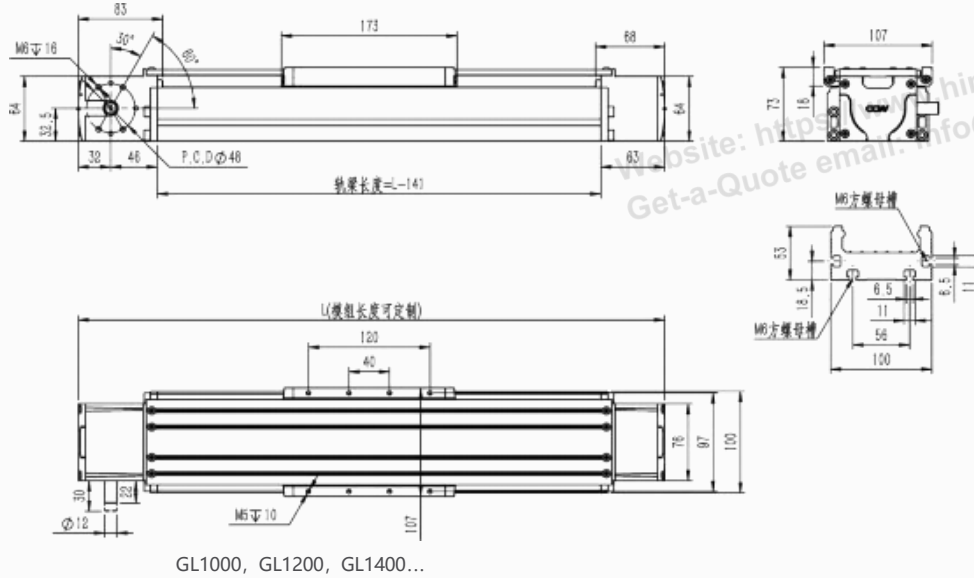

GL1000, GL1200, GL1400...

Model : W100

Guide Width : 100MM

Max Load : 30 KG

Pitch : 125 MM

Straightness : 0.05 / 300 MM

Recommended speed : 0.5~1.5 M/s

Input Torque : ≤ 4.5 N.M

■ Customized Length : Up to 6 meters * 100MM
1000MM、1100MM、1200MM...
Length of 50mm increase and decrease, such as
1000mm, 1050mm, 1100mm...

■ Belt Spec. : PU-5M-33(STD)

■ Synchronous Wheel Spec. : HTD-K5M-25Z

■ Applicable Motor and Mounting Way

I. Stepper Motor: Nema 23 (Direct Connection/Speed Reducer Set) ; Nema 34 (DC/Speed Reducer Set)

II.Servo Motor: 400W (or 200W/750W)



Model		W100
Carriage Parameter	Fx max (N)	650
	Fy max (N)	1000
	Fz max (N)	1000
	Mx max (N.M)	38
	My max (N.M)	50
	Mz max (N.M)	25
$(\text{Max. Load}) = \frac{F_y}{F_{y\max}} + \frac{F_z}{F_{z\max}} + \frac{M_x}{M_{x\max}} + \frac{M_y}{M_{y\max}} + \frac{M_z}{M_{z\max}} \leq 1$		
<p>•The maximum load coefficient is the coefficient of the linear module's operating life of 10000KM, which is the final basis for linear module selection. (It needs to consider the force and torque generated by acceleration in single or multiple-axis)</p>		

WH35

WH Series

■ Dimensions (Unit : mm)

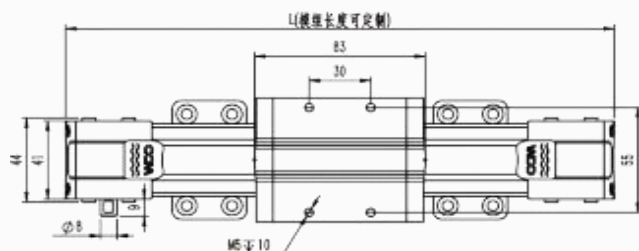
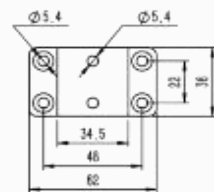
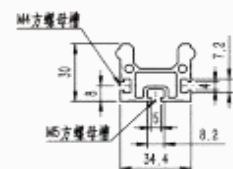
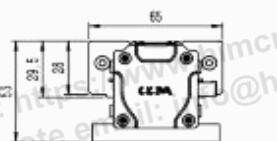
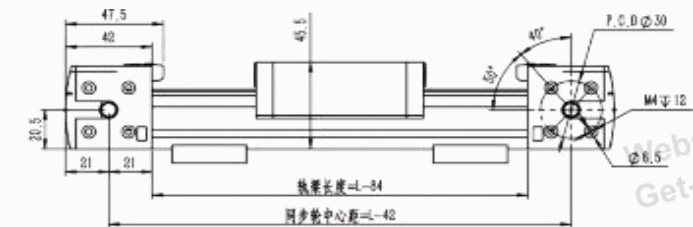

GL800, GL1000, GL1200....

- Model : WH35
- Guide Width : 35 MM
- Max Load : 3 KG
- Pitch : 63 MM
- Straightness : 0.03 / 300 MM
- Recommended speed : 0.3~1.2M/S
- Input Torque : ≤ 1 N.M
- Customized Length : Up to 1.5 meters * 100MM , 1000MM、1100MM、1200MM...
Length of 50mm increase and decrease, such as 1000mm, 1050mm, 1100mm...
- Belt Spec. : PU-3M-15 (Stainless Steel)
- Synchronous Wheel Spec. : HTD3M-21Z
- Applicable Motor and Mounting Way
 - I. Stepper Motor: Nema 17 (Direct Connection) ; Nema 23 (DC)
 - II. Servo Motor: 100W (Direct Connection)

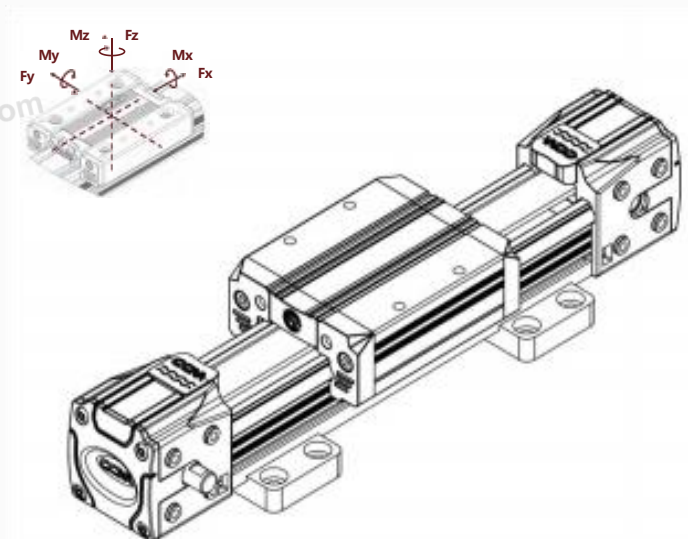

Model	WH35	
Carriage Parameter	Fx max (N)	90
	Fy max (N)	250
	Fz max (N)	210
	Mx max (N.M)	8.1
	My max (N.M)	9.6
	Mz max (N.M)	4.2
$(\text{Max Load}) = \frac{Fy}{Fy_{\text{max}}} + \frac{Fz}{Fz_{\text{max}}} + \frac{Mx}{Mx_{\text{max}}} + \frac{My}{My_{\text{max}}} + \frac{Mz}{Mz_{\text{max}}} \leq 1$ <p>The maximum load coefficient is the coefficient of the linear module's operating life of 10000KM, which is the final basis for linear module selection. (It needs to consider the force and torque generated by acceleration in single or multiple-axis)</p>		

WH100

WH Series

■ Dimensions (Unit : mm)

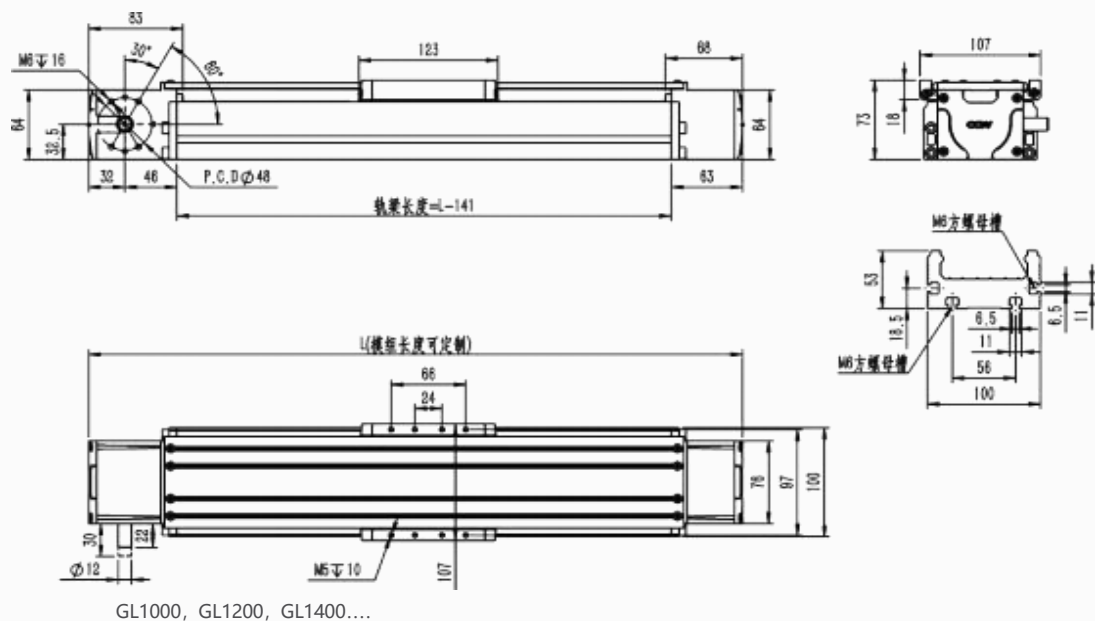

- Model : WH100
- Guide Width : 100 MM
- Max Load : 30 KG
- Pitch : 125 MM
- Straightness : 0.05 / 300 MM
- Recommended speed : 0.5~1.5M/S
- Input Torque : ≤4.5 N.M
- Customized Length : Up to 6 meters *100MM
1000MM、1100MM、1200MM...
Length of 50mm increase and decrease, such as
1000mm, 1050mm, 1100mm...
- Belt Spec. : PU-K5M-33
- Synchronous Wheel Spec. : HTD-K5M-25Z
- Applicable Motor and Mounting Way
 - I. Stepper Motor: Nema 23 (Direct Connection/Speed Reducer Set) ; Nema 34 (DC/Speed Reducer Set)
 - II. Servo Motor: 400W (or 200W/750W)

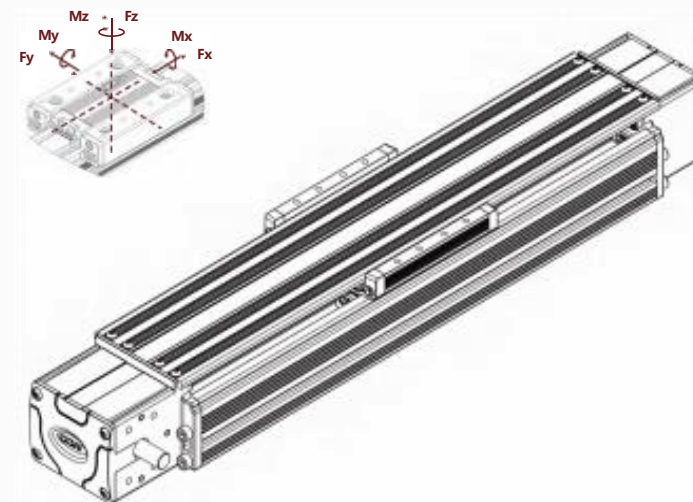

Model	WH100
Fx max (N)	650
Fy max (N)	500
Fz max (N)	500
Mx max (N.M)	38
My max (N.M)	50
Mz max (N.M)	30

$$(\text{Max. Load}) = \frac{F_y}{F_{y\max}} + \frac{F_z}{F_{z\max}} + \frac{M_x}{M_{x\max}} + \frac{M_y}{M_{y\max}} + \frac{M_z}{M_{z\max}} \leq 1$$

• The maximum load coefficient is the coefficient of the linear module's operating life of 10000KM, which is the final basis for linear module selection. (It needs to consider the force and torque generated by acceleration in single or multiple-axis)

H45 - 20

H Series

■ Dimensions (Unit : mm)

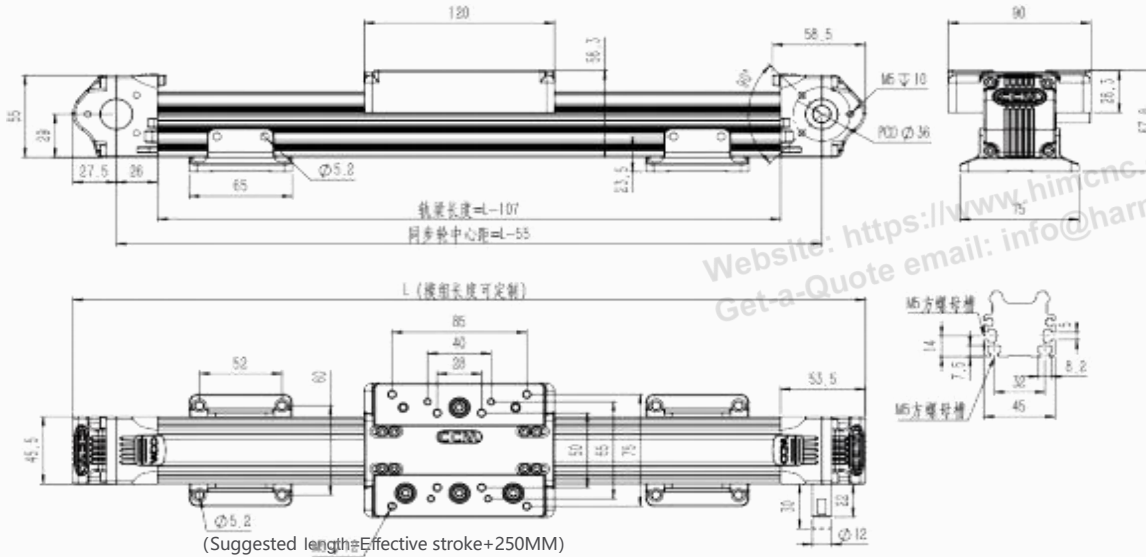

Model		H45 - 20
Carriage Parameter	Fx max (N)	200
	Fy max (N)	983
	Fz max (N)	1142
	Mx max (N.M)	21.7
	My max (N.M)	54.3
	Mz max (N.M)	23.3

$$(\text{Max. Load}) = \frac{Fy}{Fy_{\text{max}}} + \frac{Fz}{Fz_{\text{max}}} + \frac{Mx}{Mx_{\text{max}}} + \frac{My}{My_{\text{max}}} + \frac{Mz}{Mz_{\text{max}}} \leq 1$$

The maximum load coefficient is the coefficient of the linear module's operating life of 10000KM, which is the final basis for linear module selection. (It needs to consider the force and torque generated by acceleration in single or multiple-axis)

- Model : H45-20
- Guide Width : 45 MM
- Max Load : 20KG
- Pitch : 80 MM
- Straightness : 0.05 / 300 MM
- Recommended speed : ≤ 1.5 M/s
- Input Torque : ≤ 3 N.M
- Customized Length : Up to 4 meters *50MM, 1000MM、 1050MM、 1100MM...
Length of 50mm increase and decrease, such as 1000mm, 1050mm, 1100mm...
- Belt Spec. : PU-5M-15(Stainless Steel)
- Synchronous Wheel Spec. : STD5M-16Z
- Applicable Motor and Mounting Way
 - I. Stepper Motor: Nema 17 (Direct Connection) ; Nema 23 (DC/Speed Reducer Set)
 - II. Servo Motor: 100W (Direct Connection) ; 200W/400W (DC/Speed Reducer Set)

H60 - 40

H Series

■ Dimensions (Unit : mm)

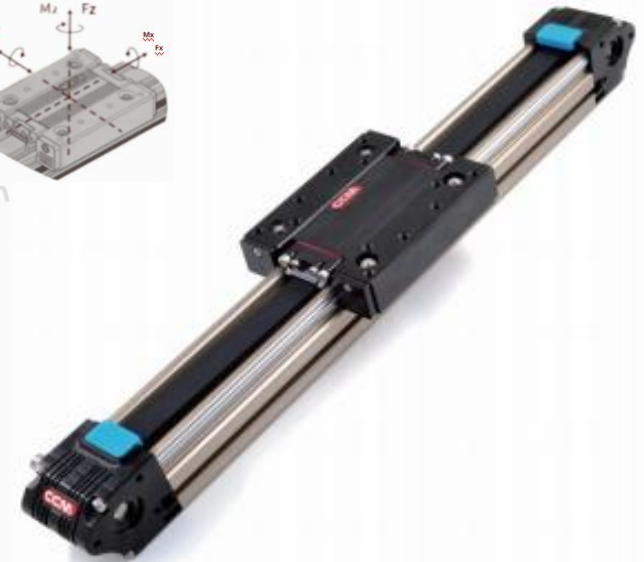
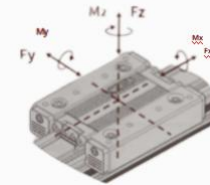
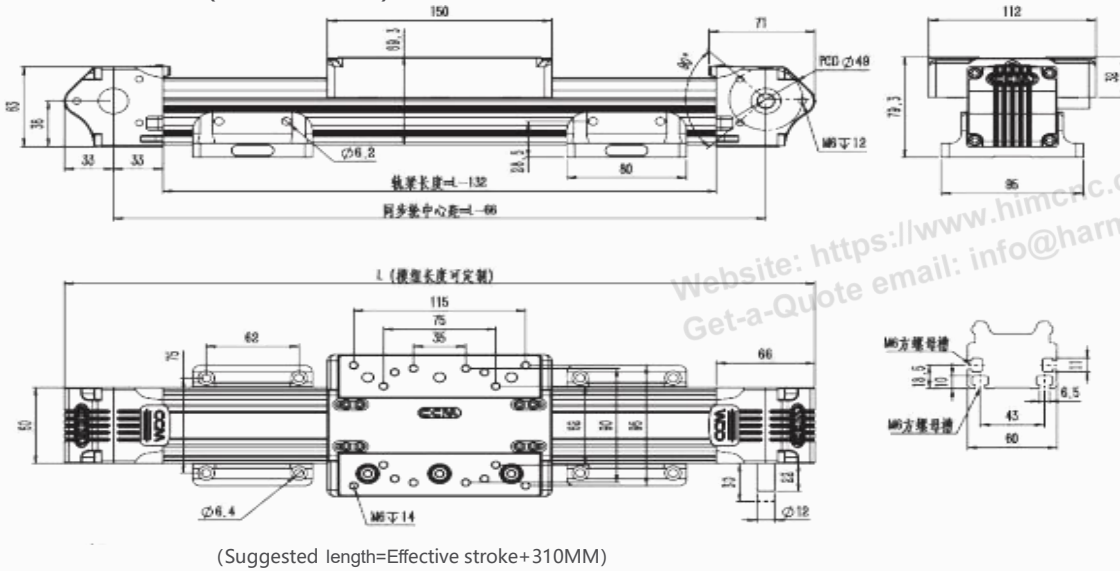

- Model : H60-40
- Guide Width : 60 MM
- Max Load : 40 KG
- Pitch : 95 MM
- Straightness : 0.05 / 300 MM
- Recommended speed : ≤ 2 M/s
- Input Torque : ≤ 8.5 N.M
- Customized Length : Up to 6 meters * 50MM
1000MM, 1050MM, 1100MM...
Length of 50mm increase and decrease, such as
1000mm, 1050mm, 1100mm...
- Belt Spec. : PU-5M-20(STD)
- Synchronous Wheel Spec. : STD5M-19Z
- Applicable Motor and Mounting Way
 - I. Stepper Motor: Nema 23 (Direct Connection/Speed Reducer Set) ; Nema 34 (DC/Speed Reducer Set)
 - II. Servo Motor: 750W (Direct Connection) ; 200W/400W (DC/Speed Reducer Set)

Model	H60 - 40	
Carriage Parameter	$F_x F_{x\max}$ (N(N))	500
	$F_y F_{y\max}$ (N(N))	1502
	$F_z F_{z\max}$ (N(N))	1746
	$M_x \max$ (N.M)	48.9
	$M_y \max$ (N.M)	124
	$M_z \max$ (N.M)	53.3
$\{ \text{Max. Load} \} = \frac{F_y}{F_{y\max}} + \frac{F_z}{F_{z\max}} + \frac{M_x}{M_{x\max}} + \frac{M_y}{M_{y\max}} + \frac{M_z}{M_{z\max}} \leq 1$ <p>The maximum load coefficient is the coefficient of the linear module's operating life of 10000KM, which is the final basis for linear module selection. (It needs to consider the force and torque generated by acceleration in single or multiple-axis)</p>		

H80 - 50

H Series

Dimensions (Unit : mm)

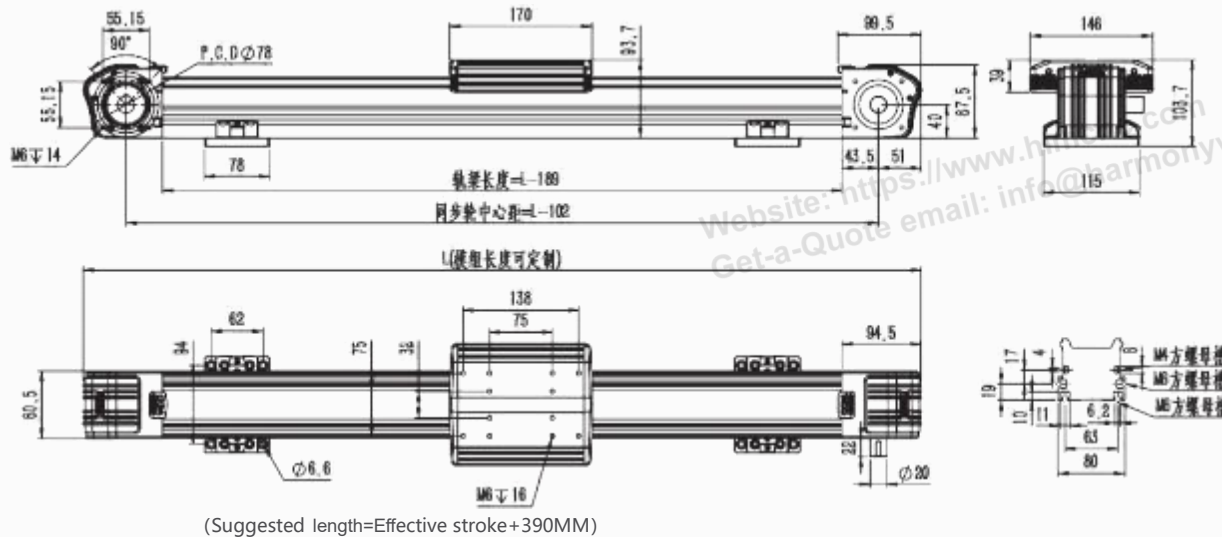

- Model : H80-50
- Guide Width : 80 MM
- Max Load : 50 KG
- Pitch : 190 MM
- Straightness : 0.05 / 300 MM
- Recommended speed : ≤ 2 M/s
- Input Torque : ≤13.5 N.M
- Customized Length : Up to 6 meters
* 50MM 1000MM、1050MM、1100MM...
Length of 50mm increase and decrease, such as
1000mm, 1050mm, 1100mm...
- Belt Spec. : PU-5M-33 (STD)
- Synchronous Wheel Spec. : STD5M-38Z
- Applicable Motor and Mounting Way
 - I. Stepper Motor: Nema 34 / Nema 42 (Direct Connection)
 - II. Servo Motor: 400W / 750W / 1000W / 1500W (Direct Connection)

Model	H80 - 50	
Carriage Parameter	Fx max (N)	700
	Fy max (N)	1442
	Fz max (N)	1677
	Mx max (N.M)	63.7
	My max (N.M)	88.9
	Mz max (N.M)	38.2
$(\text{Max. Load}) = \frac{Fy}{Fy_{\text{max}}} + \frac{Fz}{Fz_{\text{max}}} + \frac{Mx}{Mx_{\text{max}}} + \frac{My}{My_{\text{max}}} + \frac{Mz}{Mz_{\text{max}}} \leq 1$		
*The maximum load coefficient is the coefficient of the linear module's operating life of 10000KM, which is the final basis for linear module selection. (It needs to consider the force and torque generated by acceleration in single or multiple-axis)		

L45 - 15

L Series

■ Dimensions (Unit : mm)

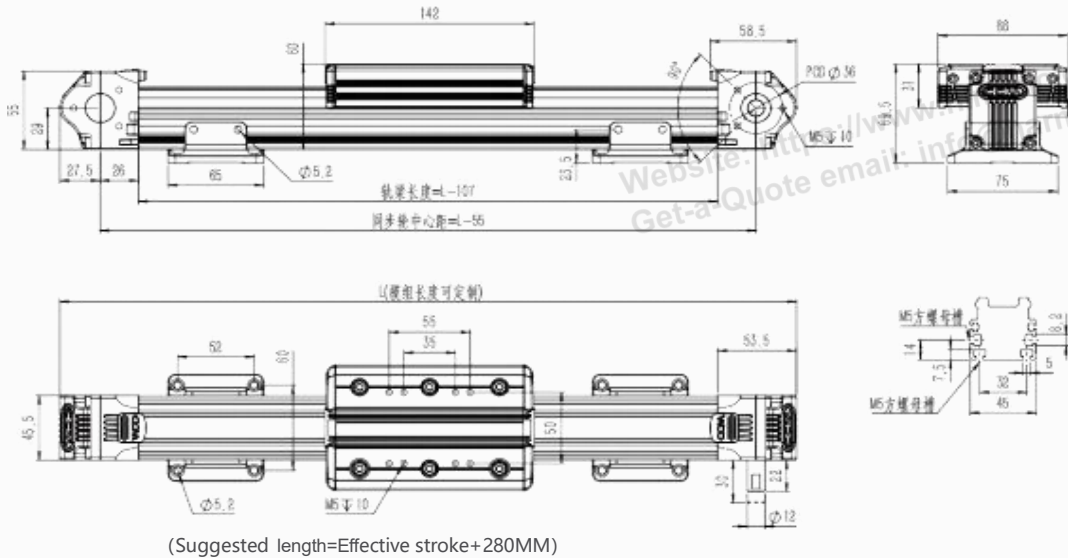

- Model : L45-15
- Guide Width : 45 MM
- Max Load : 15 KG
- Pitch : 80 MM
- Straightness : 0.05 / 300 MM
- Recommended speed : ≤ 1.5 M/s
- Input Torque : ≤ 3 N.M
- Customized Length : Up to 4 meters * 50MM , 1000MM、1050MM、1100MM...
Length of 50mm increase and decrease, such as 1000mm, 1050mm, 1100mm...
- Belt Spec. : PU-5M-15(Stainless Steel)
- Synchronous Wheel Spec. : STD5M-16Z
- Applicable Motor and Mounting Way
I. Stepper Motor: Nema 17 (Direct Connection) ; Nema

Model	L45 - 15	
Carriage Parameter	Fx max (N)	200
	Fy max (N)	983
	Fz max (N)	1142
	Mx max (N.M)	21.7
	My max (N.M)	54.3
	Mz max (N.M)	23.3
$\text{(Max.Load)} = \frac{F_y}{F_{y\max}} + \frac{F_z}{F_{z\max}} + \frac{M_x}{M_{x\max}} + \frac{M_y}{M_{y\max}} + \frac{M_z}{M_{z\max}} \leq 1$		
• The maximum load coefficient is the coefficient of the linear module's operating life of 10000KM, which is the final basis for linear module selection. (It needs to consider the force and torque generated by acceleration in single or multiple-axis)		

L50 - 25

L Series

■ Dimensions (Unit : mm)

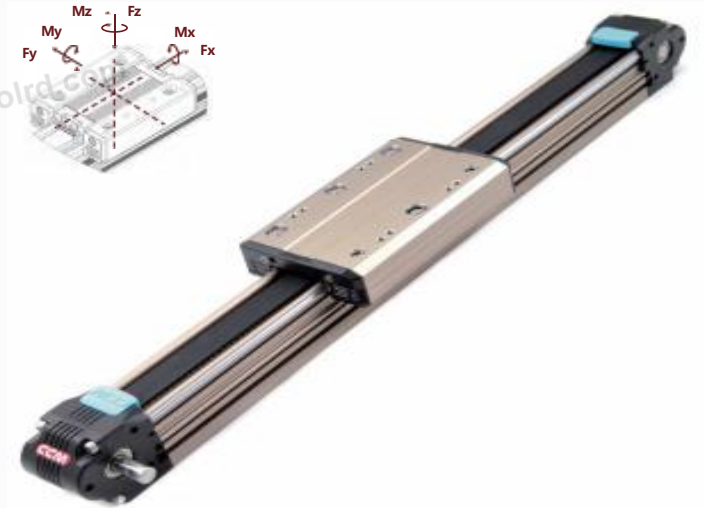
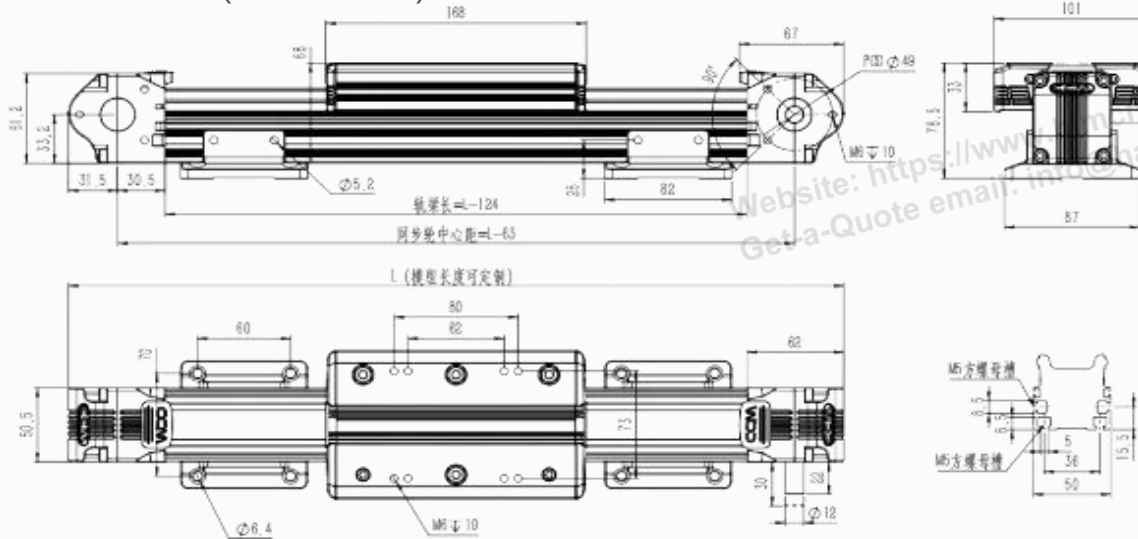

- Model : L50-25
- Guide Width : 50 MM
- Max Load : 25 KG
- Pitch : 95 MM
- Straightness : 0.05 / 300 MM
- Recommended speed : ≤ 2 M/s
- Input Torque : ≤6.5 N.M
- Customized Length : Up to 6 meters * 50MM
1000MM、1050MM、1100MM...
Length of 50mm increaseand decrease, such as
1000mm, 1050mm, 1100mm...
- Belt Spec. : PU-5M-20(STD)
- Synchronous Wheel Spec. : STD5M-19Z
- Applicable Motor and Mounting Way
 - I. Stepper Motor: Nema 23 (Direct Connection/Speed Reducer Set) ; Nema 34 (DC/Speed Reducer Set)
 - II. Servo Motor: 750W (Direct Connection) ; 200W/400W (DC/Speed Reducer Set)

Model	L50 - 25	
Carriage Parameter	Fx max (N)	500
	Fy max (N)	1502
	Fz max (N)	1746
	Mx max (N.M)	26.3
	My max (N.M)	68.5
	Mz max (N.M)	29.5
$(\text{Max. Load}) = \frac{Fy}{Fy_{\max}} + \frac{Fz}{Fz_{\max}} + \frac{Mx}{Mx_{\max}} + \frac{My}{My_{\max}} + \frac{Mz}{Mz_{\max}} \leq 1$		
• The maximum load coefficient is the coefficient of the linear module's operating life of 10000KM, which is the final basis for linear module selection. (It needs to consider the force and torque generated by acceleration in single or multiple-axis)		

L60 - 35

L Series

■ Dimensions (Unit : mm)

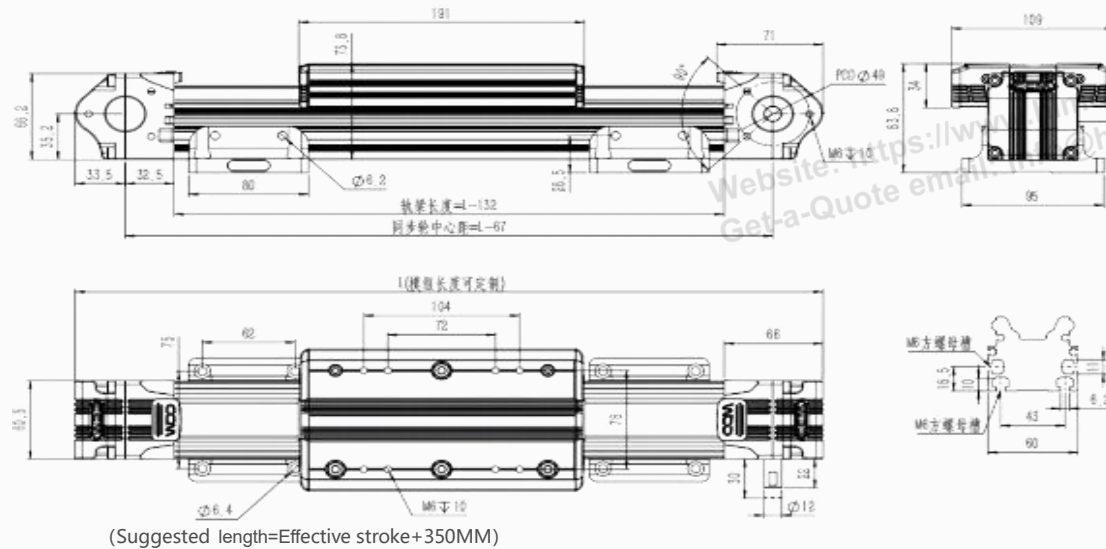

- Model : L60-35
- Guide Width : 60 MM
- Max Load : 35 KG
- Pitch : 110 MM
- Straightness : 0.05 / 300 MM
- Recommended speed : ≤ 2 M/s
- Input Torque : ≤8.5 N.M
- Customized Length : Up to 6 meters *
50MM 1000MM、1050MM、1100MM...
Length of 50mm increaseand decrease, such as
1000mm, 1050mm, 1100mm...
- Belt Spec. : PU-5M-20(STD)
- Synchronous Wheel Spec. : STD5M-22Z
- Applicable Motor and Mounting Way
 - I. Stepper Motor: Nema 23 (Direct Connection/Speed Reducer Set) ; Nema 34 (DC/Speed Reducer Set)
 - II. Servo Motor: 750W (Direct Connection) ; 200W/400W (DC/Speed Reducer Set)

Model		L60 - 35
Carriage Parameter	Fx max (N)	500
	Fy max (N)	1502
	Fz max (N)	1746
	Mx max (N.M)	48.9
	My max (N.M)	124
	Mz max (N.M)	53.3
$\frac{Fy}{Fy_{max}} + \frac{Fz}{Fz_{max}} + \frac{Mx}{Mx_{max}} + \frac{My}{My_{max}} + \frac{Mz}{Mz_{max}} \leq 1$		
• The maximum load coefficient is the coefficient of the linear module's operating life of 10000KM,which is the final basis for linear moduleselection.(It needs to consider the force and torque generated by acceleration in single or multiple-axis)		

L80 - 60

L Series

■ Dimensions (Unit : mm)

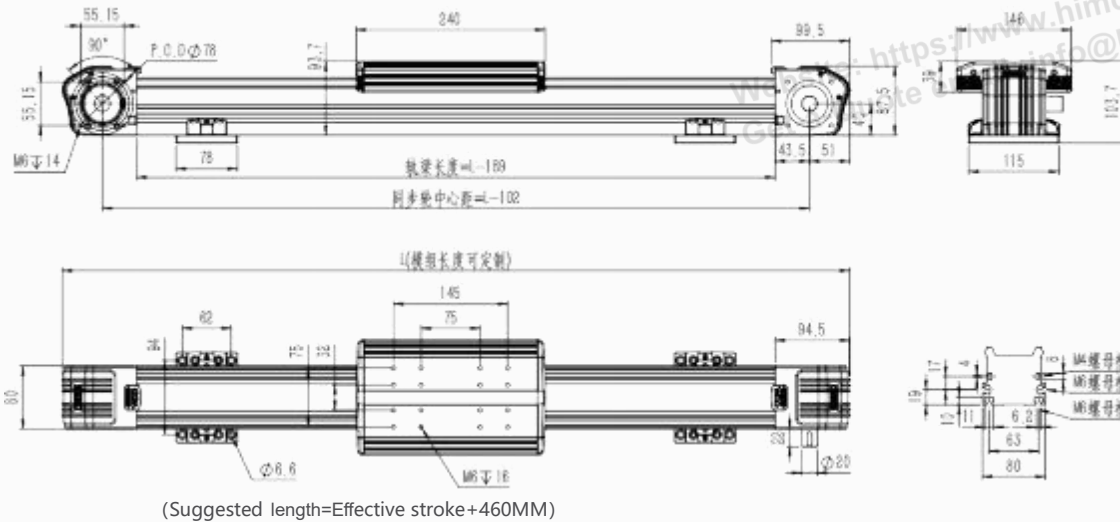

- Model : L80-60
- Guide Width : 80 MM
- Max Load : 60 KG
- Pitch : 190 MM
- Straightness : 0.05 / 300 MM
- Recommended speed : ≤ 2 M/s
- Input Torque : ≤13.5 N.M
- Customized Length : Up to 6 meters
* 50MM 1000MM、1050MM、1100MM...
Length of 50mm increase and decrease, such as 1000mm, 1050mm, 1100mm...
- Belt Spec. : PU-5M-33 (STD)
- Synchronous Wheel Spec. : STD5M-38Z
- Applicable Motor and Mounting Way
I. Stepper Motor: Nema 34 / Nema 42 (Direct Connection)
II. Servo Motor: 400W / 750W / 1000W / 1500W (Direct Connection)

Model		L80 - 60
Carriage Parameter	Fx max (N)	700
	Fy max (N)	2163
	Fz max (N)	2515
	Mx max (N.M)	95.6
	My max (N.M)	228.9
	Mz max (N.M)	98.4
$(\text{Max. Load}) = \frac{F_y}{F_{y\max}} + \frac{F_z}{F_{z\max}} + \frac{M_x}{M_{x\max}} + \frac{M_y}{M_{y\max}} + \frac{M_z}{M_{z\max}} \leq 1$		
• The maximum load coefficient is the coefficient of the linear module's operating life of 10000KM, which is the final basis for linear module selection. (It needs to consider the force and torque generated by acceleration in single or multiple-axis)		

Z45 - 15

Z Series

■ Dimensions (Unit : mm)

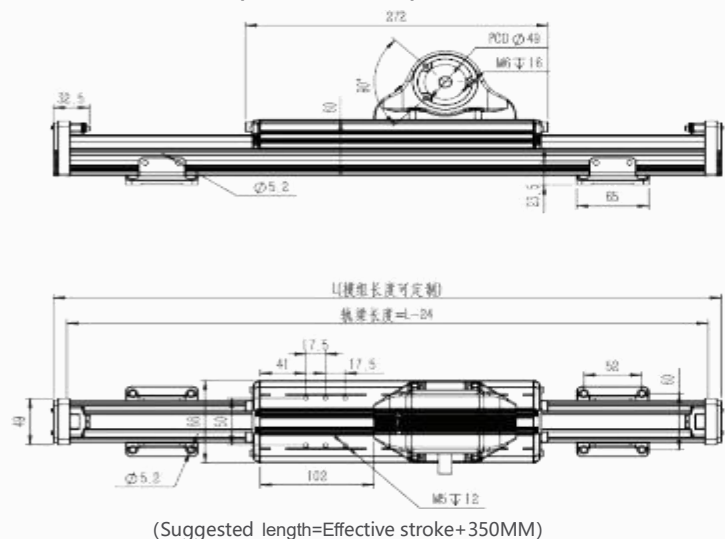

Website: www.himcnc.com
Get-a-Quote email: info@harmonywold.com

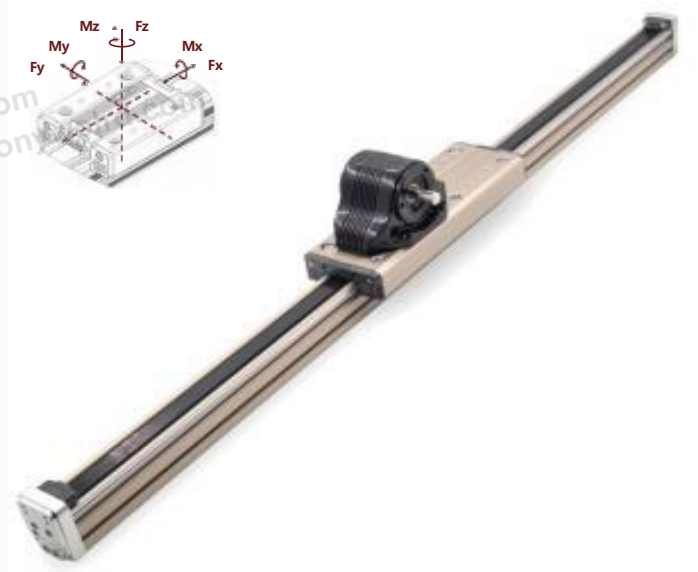
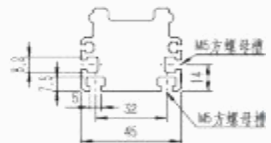

- Model : Z45-15
- Guide Width : 45 MM
- Max Load : 15 KG
- Pitch : 110 MM
- Straightness : 0.05 / 300 MM
- Recommended speed : ≤ 1.5 M/s
- Input Torque : ≤3 N.M

- Customized Length : Up to 6 meters * 50MM , 1000MM、1050MM、1100MM... Length of 50mm increase and decrease, such as 1000mm, 1050mm, 1100mm...
- Belt Spec. : PU-5M-15(STD)
- Synchronous Wheel Spec. : STD5M-22Z
- Applicable Motor and Mounting Way

- I. Stepper Motor: Nema 23 (Direct Connection/Speed Reducer Set) ; Nema 34 (DC/Speed Reducer Set)
- II. Servo Motor: 750W (Direct Connection) ; 200W/400W (DC/Speed Reducer Set)

Model		Z45 - 15
Carriage Parameter	Fx max (N)	200
	Fy max (N)	688
	Fz max (N)	800
	Mx max (N.M)	15.2
	My max (N.M)	85.2
	Mz max (N.M)	36.6
$(\text{Max. Load}) = \frac{Fy}{Fy_{\text{max}}} + \frac{Fz}{Fz_{\text{max}}} + \frac{Mx}{Mx_{\text{max}}} + \frac{My}{My_{\text{max}}} + \frac{Mz}{Mz_{\text{max}}} \leq 1$		
• The maximum load coefficient is the coefficient of the linear module's operating life of 10000KM, which is the final basis for linear module selection. (It needs to consider the force and torque generated by acceleration in single or multiple-axis)		

Z50 - 25

Z Series

■ Dimensions (Unit : mm)

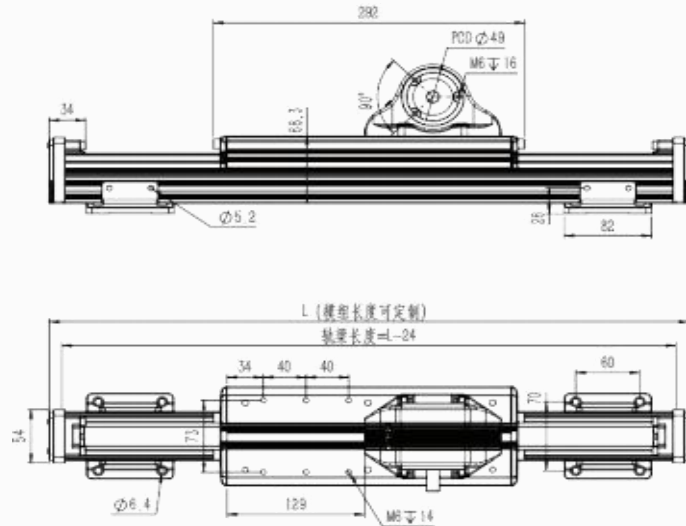

(Suggested length=Effective stroke+380MM)

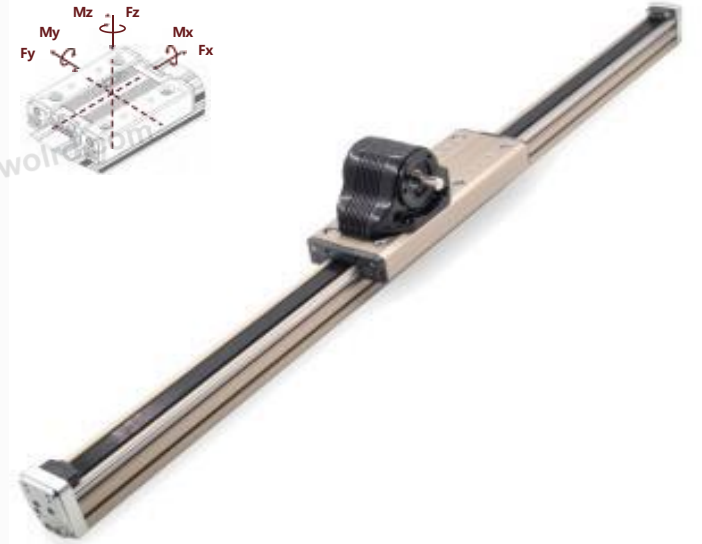
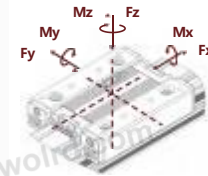
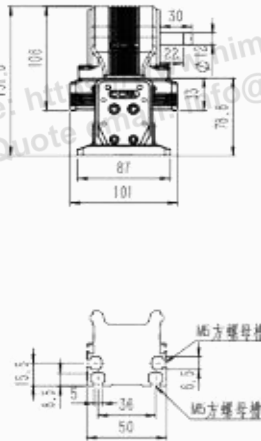

- Model : Z50-25
- Guide Width : 50 MM
- Max Load : 25 KG
- Pitch : 110 MM
- Straightness : 0.05 / 300 MM
- Recommended speed : ≤ 2 M/s
- Input Torque : ≤6.5 N.M
- Customized Length : Up to 6 meters * 50MM
1000MM、1050MM、1100MM...
Length of 50mm increase and decrease, such as 1000mm, 1050mm, 1100mm...
- Belt Spec. : PU-5M-20(STD)
- Synchronous Wheel Spec. : STD5M-22Z
- Applicable Motor and Mounting Way
 - I. Stepper Motor: Nema 23 (Direct Connection/Speed Reducer Set) ; Nema 34 (DC/Speed Reducer Set)
 - ii. II. Servo Motor: 750W (Direct Connection) ; 200W/400W (DC/Speed Reducer Set)

Model		Z50 - 25
Carriage Parameter	Fx max (N)	500
	Fy max (N)	1051
	Fz max (N)	1222
	Mx max (N.M)	18.4
	My max (N.M)	92.8
	Mz max (N.M)	39.9
$(\text{Max. Load}) = \frac{F_y}{F_{y\max}} + \frac{F_z}{F_{z\max}} + \frac{M_x}{M_{x\max}} + \frac{M_y}{M_{y\max}} + \frac{M_z}{M_{z\max}} \leq 1$		
• The maximum load coefficient is the coefficient of the linear module's operating life of 10000KM, which is the final basis for linear module selection. (It needs to consider the force and torque generated by acceleration in single or multiple-axis)		

Z60 - 35

Z Series

■ Dimensions (Unit : mm)

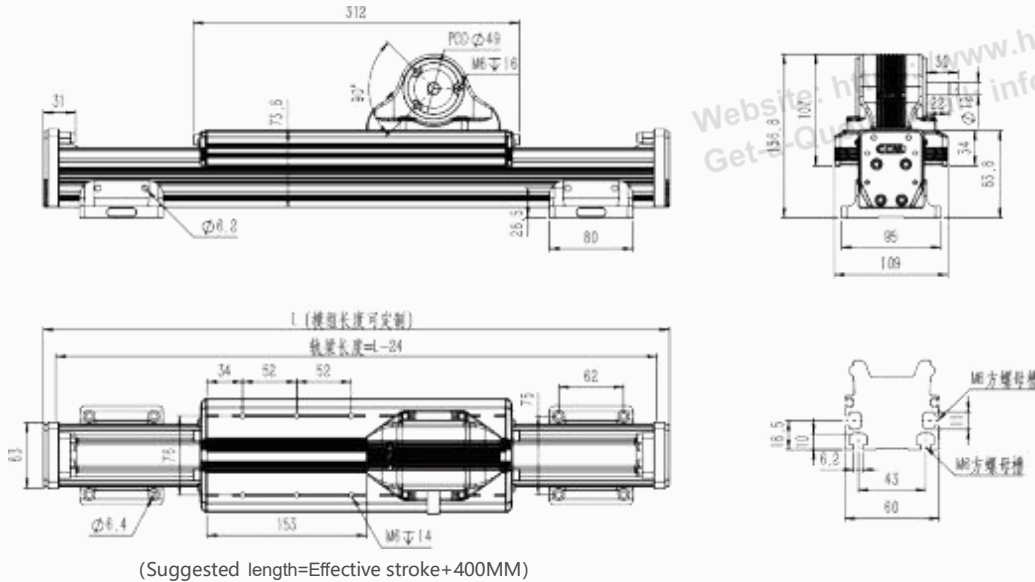

- Model : Z60-35
- Guide Width : 60 MM
- Max Load : 35 KG
- Pitch : 110 MM
- Straightness : 0.05 / 300 MM
- Recommended speed : ≤ 2 M/s
- Input Torque : ≤ 6.5 N.M
- Customized Length : Up to 6 meters * 50MM
1000MM、1050MM、1100MM...
Length of 50mm increase and decrease, such as
1000mm, 1050mm, 1100mm...
- Belt Spec. : PU-5M-20(STD)
- Synchronous Wheel Spec. : STD5M-22Z
- Applicable Motor and Mounting Way
 - I. Stepper Motor: Nema 23 (Direct Connection/Speed Reducer Set) ; Nema 34 (DC/Speed Reducer Set)
 - II. Servo Motor: 750W (Direct Connection) ; 200W/400W (DC/Speed Reducer Set)



Model		Z60 - 35
Carriage Parameter	Fx max (N)	500
	Fy max (N)	1051
	Fz max (N)	1222
	Mx max (N.M)	34.2
	My max (N.M)	153.4
	Mz max (N.M)	66
$(\text{Max. Load}) = \frac{F_y}{F_{y\max}} + \frac{F_z}{F_{z\max}} + \frac{M_x}{M_{x\max}} + \frac{M_y}{M_{y\max}} + \frac{M_z}{M_{z\max}} \leq 1$		
•The maximum load coefficient is the coefficient of the linear module's operating life of 10000KM, which is the final basis for linear module selection. (It needs to consider the force and torque generated by acceleration in single or multiple-axis)		

Z80 - 50

Z Series

■ Dimensions (Unit : mm)

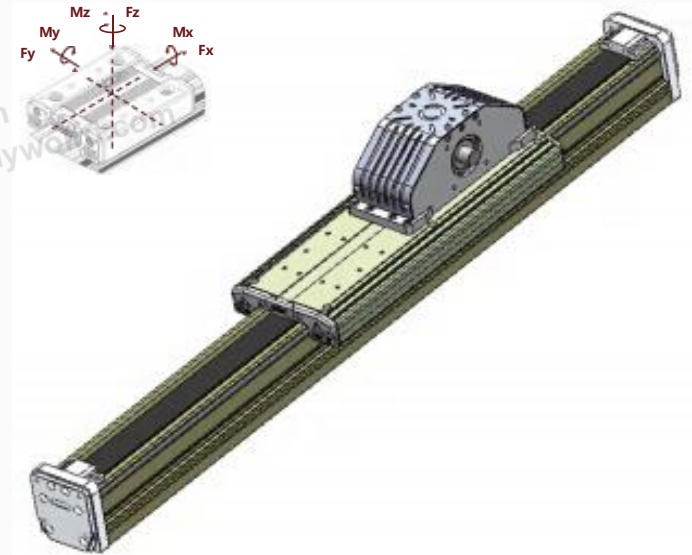
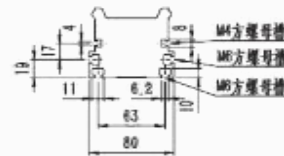
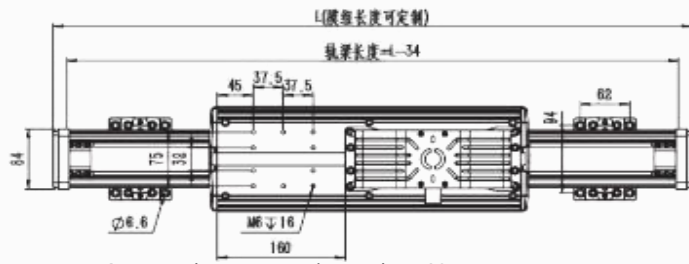
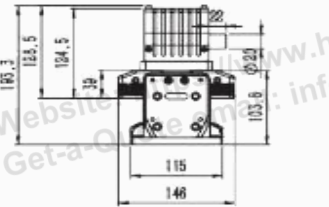
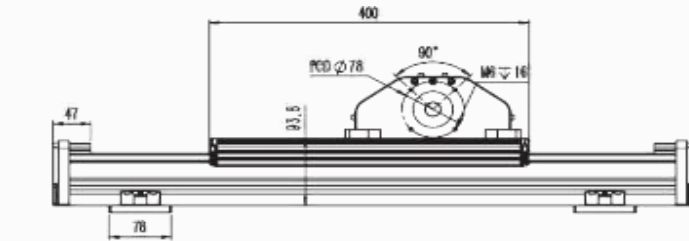

- Model : Z80-50
- Guide Width : 80 MM
- Max Load : 50 KG
- Pitch : 190 MM
- Straightness : 0.05 / 300 MM
- Recommended speed : ≤ 2 M/s
- Input Torque : ≤ 13.5 N.M
- Customized Length : Up to 6 meters
50MM 1000MM、1050MM、1100MM...
Length of 50mm increase and decrease, such as 1000mm, 1050mm, 1100mm...
- Belt Spec. : PU-5M-33 (STD)
- Synchronous Wheel Spec. : STD5M-38Z
- Applicable Motor and Mounting Way
I. : 86 / 110
Stepper Motor: Nema 34 / Nema 42 (Direct Connection)
II. 400W / 750W / 1000W / 1500W
Servo Motor: 400W / 750W / 1000W / 1500W (Direct Connection)

Model		Z80 - 50
Carriage Parameter	Fx max (N)	700
	Fy max (N)	1514
	Fz max (N)	1761
	Mx max (N.M)	66.9
	My max (N.M)	272.9
	Mz max (N.M)	117.3
$(\text{Max. Load}) = \frac{F_y}{F_{y\max}} + \frac{F_z}{F_{z\max}} + \frac{M_x}{M_{x\max}} + \frac{M_y}{M_{y\max}} + \frac{M_z}{M_{z\max}} \leq 1$		
•The maximum load coefficient is the coefficient of the linear module's operating life of 10000KM, which is the final basis for linear module selection. (It needs to consider the force and torque generated by acceleration in single or multiple-axis)		

Q45

Q Series

■ Dimensions (Unit : mm)

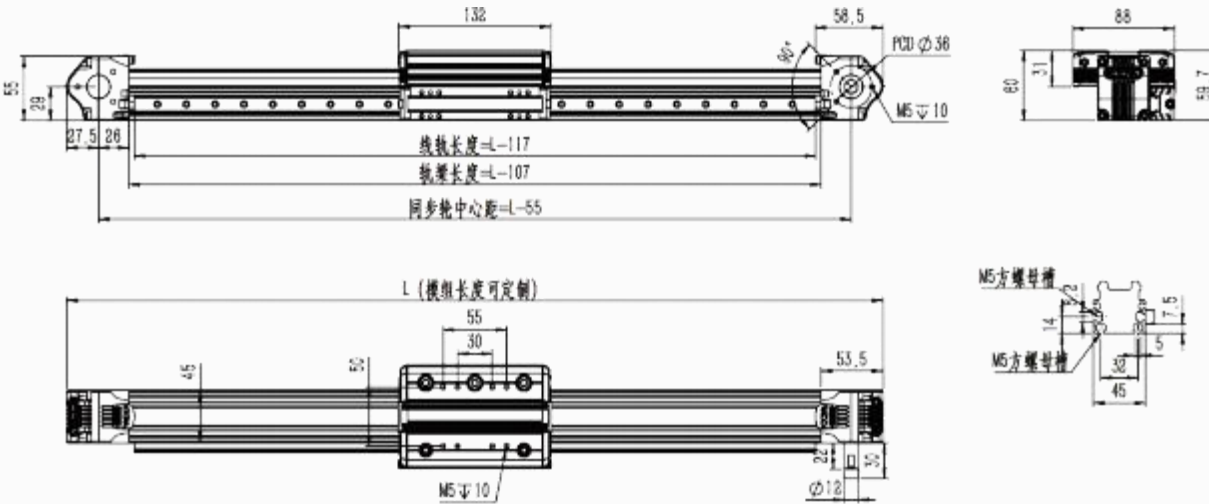

*Itinerary customization: S100, S200, S300, S1000....

- Model : Q45
- Guide Width : 45 MM
- Max Load : 15 KG
- Pitch : 80 MM
- Straightness : 0.05 / 300 MM
- Recommended speed : ≤ 1.5 M/s
- Input Torque : ≤ 3 N.M
- Customized Length : Up to 4 meters 100MM 1000MM、1100MM、1200MM...
Length of 50mm increase and decrease, such as 1000mm, 1050mm, 1100mm...
- Belt Spec. : PU-5M-15(Stainless Steel)
- Synchronous Wheel Spec. : STD5M-16Z
- Applicable Motor and Mounting Way
I. Stepper Motor: Nema 17 (Direct Connection) ; Nema 23 (DC/Speed Reducer Set)
II. Servo Motor: 100W (Direct Connection) ; 200W/400W (DC/Speed Reducer Set)

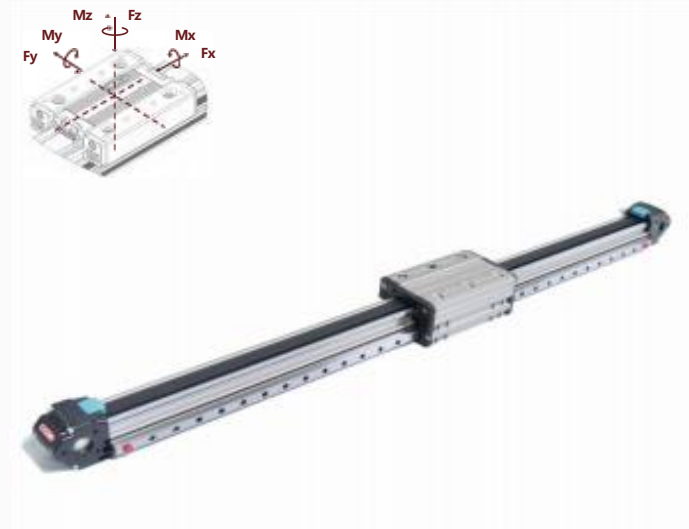

Model		Q45
Carriage Parameter	Fx max (N)	200
	Fy max (N)	983
	Fz max (N)	1142
	Mx max (N.M)	26.4
	My max (N.M)	64.3
	Mz max (N.M)	28.2
$(\text{Max. Load}) = \frac{F_y}{F_{y\max}} + \frac{F_z}{F_{z\max}} + \frac{M_x}{M_{x\max}} + \frac{M_y}{M_{y\max}} + \frac{M_z}{M_{z\max}} \leq 1$		
-The maximum load coefficient is the coefficient of the linear module's operating life of 10000KM, which is the final basis for linear module selection. (It needs to consider the force and torque generated by acceleration in single or multiple-axis)		

Q60

Q Series

■ Dimensions (Unit : mm)

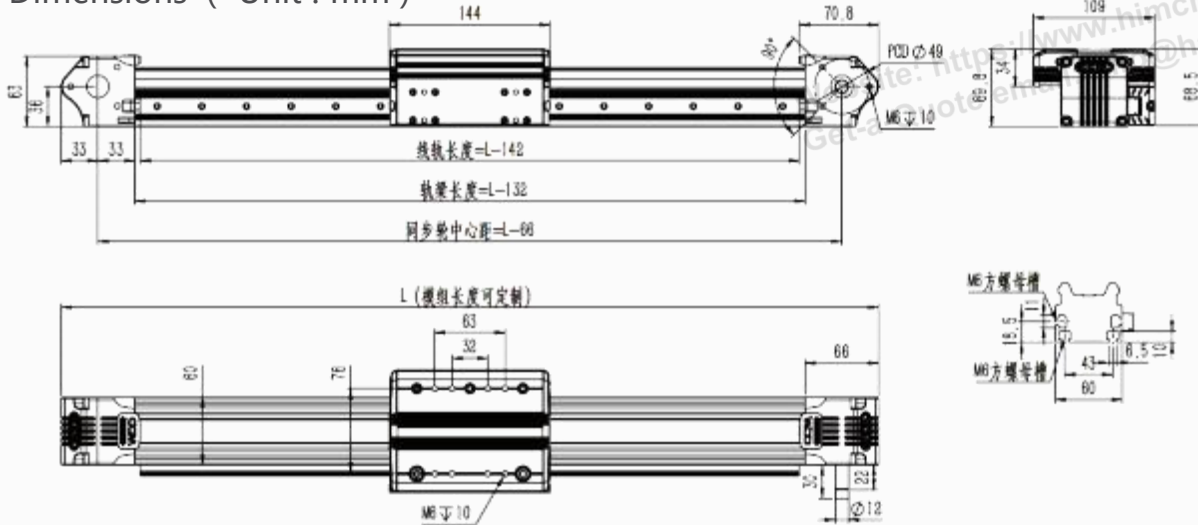

*Itinerary customization: S100, S200, S500, S1000..

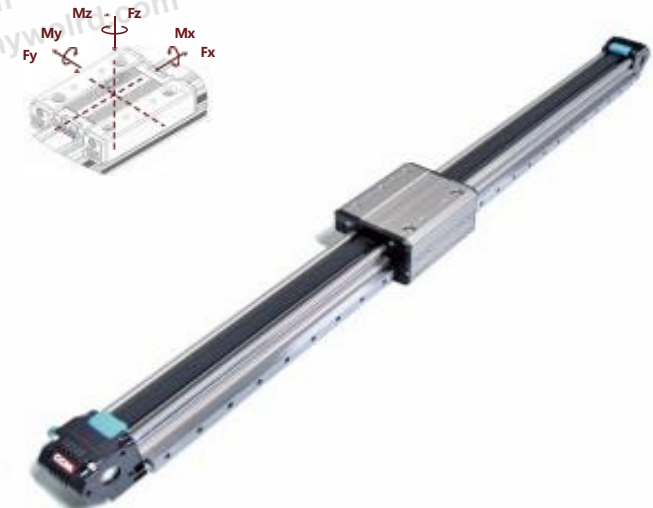

- Model : Q60
- Guide Width : 60 MM
- Max Load : 35 KG
- Pitch : 95 MM
- Straightness : 0.05 / 300 MM
- Recommended speed : ≤ 2 M/s
- Input Torque : ≤ 8.5 N.M
- Customized Length : Up to 4 meters 100MM 1000MM、1100MM、1200MM...
Length of 50mm increase and decrease, such as 1000mm, 1050mm, 1100mm...
- Belt Spec. : PU-5M-20(STD)
- Synchronous Wheel Spec. : STD5M-22Z
- Applicable Motor and Mounting Way
 - I. Stepper Motor: Nema 23 (Direct Connection/Speed Reducer Set) ; Nema 34 (DC/Speed Reducer Set)
 - II. Servo Motor: 750W (Direct Connection) ; 200W/400W (DC/Speed Reducer Set)

Model	Q60	
Carriage Parameter	Fx max (N)	500
	Fy max (N)	1502
	Fz max (N)	1746
	Mx max (N.M)	58.6
	My max (N.M)	148.8
	Mz max (N.M)	63.9
$(\text{Max. Load}) = \frac{Fy}{Fy_{\text{max}}} + \frac{Fz}{Fz_{\text{max}}} + \frac{Mx}{Mx_{\text{max}}} + \frac{My}{My_{\text{max}}} + \frac{Mz}{Mz_{\text{max}}} \leq 1$		
• The maximum load coefficient is the coefficient of the linear module's operating life of 10000KM, which is the final basis for linear module selection. (It needs to consider the force and torque generated by acceleration in single or multiple-axis)		

Auxiliary Parts

Website: <https://www.himcnc.com>
Get-a-Quote email: info@harmonywolrd.com

A Motor Brackets



B Speed Reducers

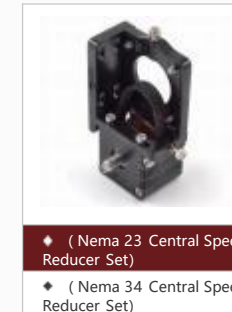
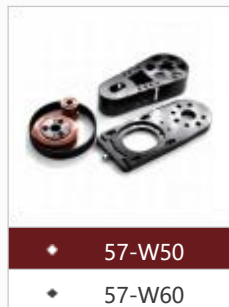

C Structural Attachments

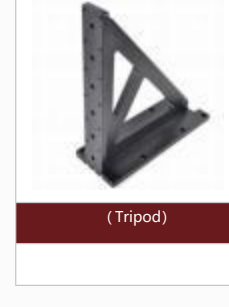
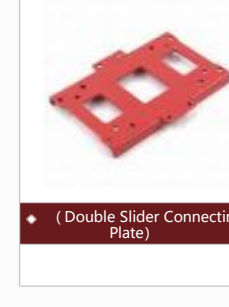
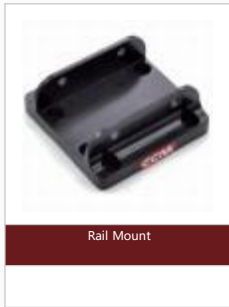

D Other Parts



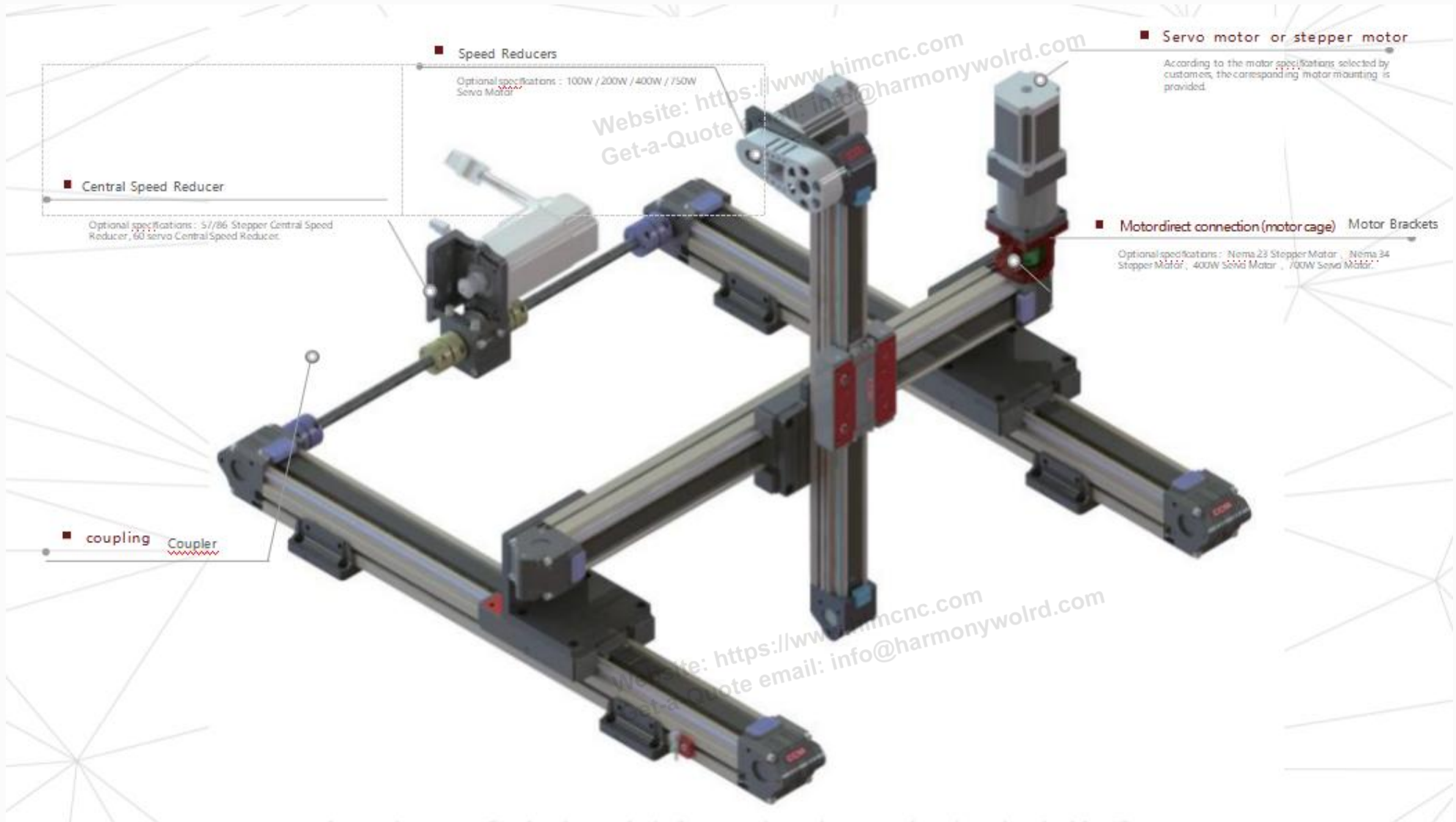

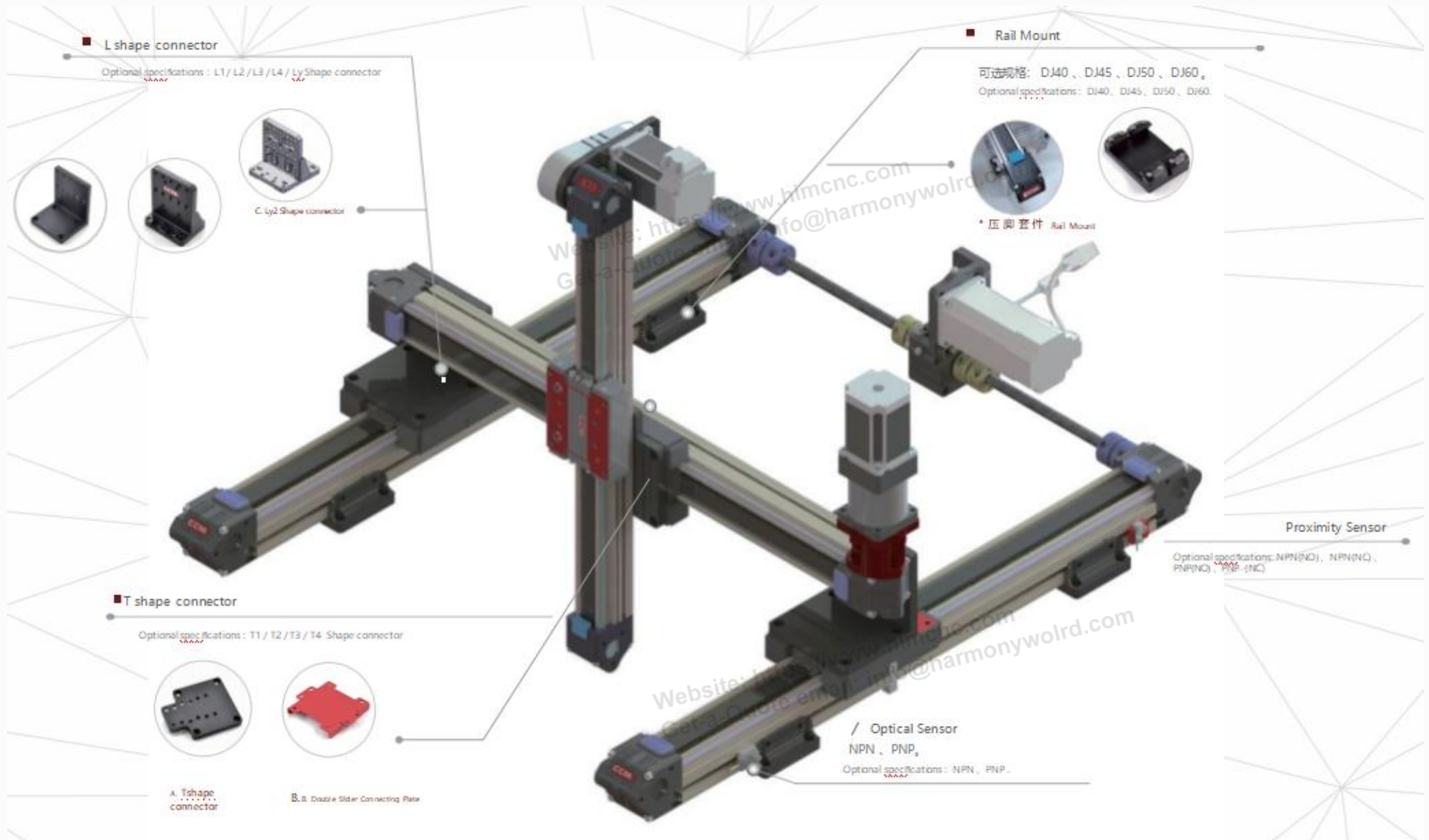

Common Structures

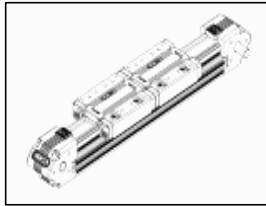

101 Single track double slider

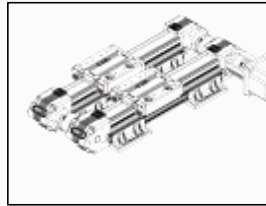

102 Double track parallel structure



1 03 Dual track synchronous structure



1 04 Double slider synchronous structure

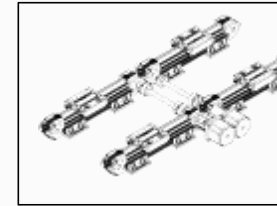

1 05 dual track multi drive structure

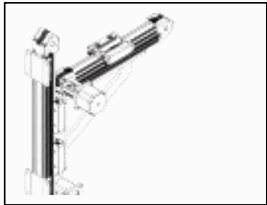

201 2D Cantilever Structure

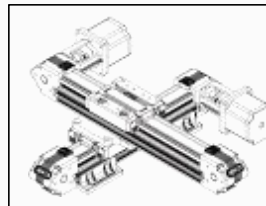

2 02 2D Cross Horizontal Structure

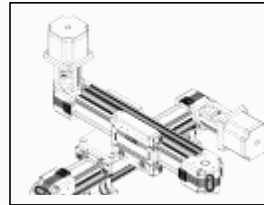

2 03 2D Cross Side Stand Structure

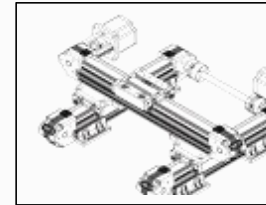

2 04 2D I-shaped structure

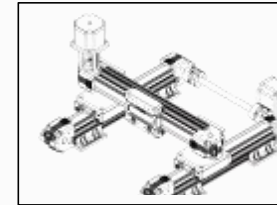

2 05 2D I-shaped side standing structure

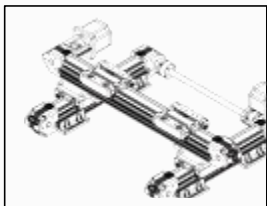

2 06 2D I-shaped double slider structure

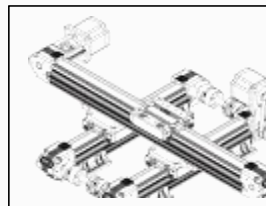

2 07 2D XYY Chinese style structure



2 08 2D XYY Chinese character side standing

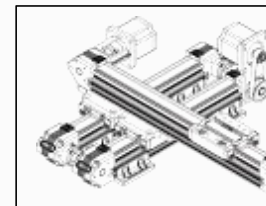

2 09 2D dry character structure

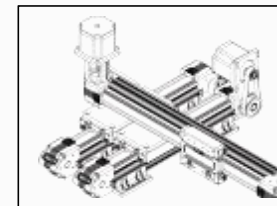

2 10 2D stem shaped side standing structure

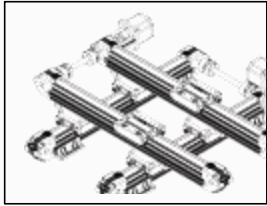

2 11 2D well shaped structure

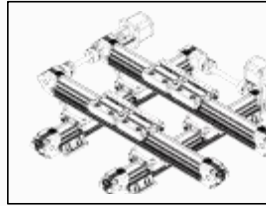

2 12 2D well shaped double slider structure

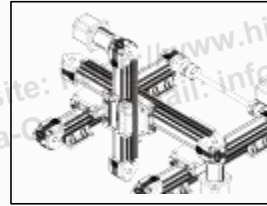

3 01 3D XYZ side standing structure

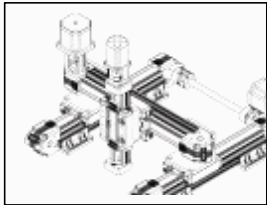

3 02 3D XYZ screw structure

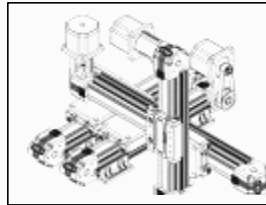

3 03 3D Dry Cantilever Structure

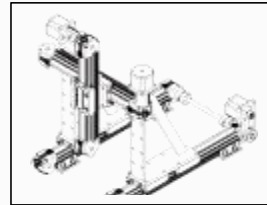

3 04 3D gantry structure

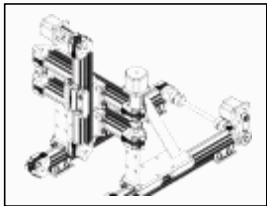

3 05 3D double axis gantry structure

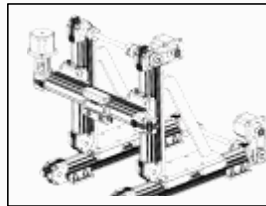

3 06 3D double Z-axis gantry structure

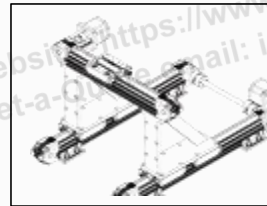

3 07 3D single XZ axis double Y axis structure

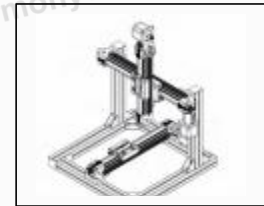

3 08 3D Aluminum Support Structure

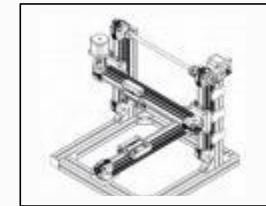

3 09 XY double Z-axis aluminum support structure

■ Versatile design for various configuration,the length of linear rail can be custom- ized as per your requests.

■ We provide high quality,protable and long service life linear rail,which can achieve mounting multi-carriages flexibly and maintenance-free.

■ There are nut grooves on the aluminium profile to fix the linear rail and others.

■ Multi-applications rail mount can be conveniently used to connect the linear rail and finish mounting the linear

■ Special design of the carriage to achieve to adjusting the tension of carriage and belt easily and quickly.