

MP3450E (Economy Type)

Applied to : N.B , Netbook , Micro-projector , PDA , GPS , MID , DSC , iphone , ipod and so on.

I. Operation panel

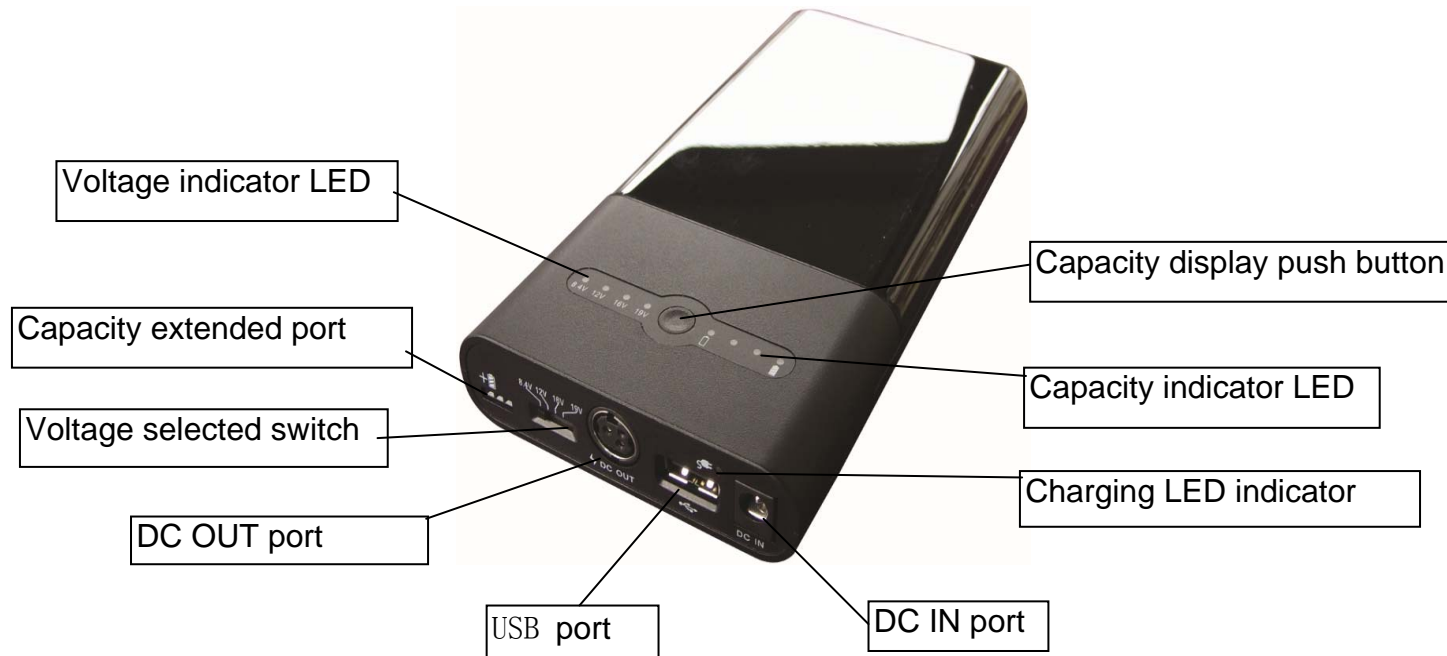

II. Function introduction

- ◆ This product is economic and practical.
- ◆ Light weight (0.4kg), fashion appearance.
- ◆ Wide input charging voltage range: 8~20V
- ◆ Charging time: 3~4 hours
- ◆ Three charging method : **a.** Power adapter **b.** Car charger **c.** Solar panel charger
- ◆ Charging LED display: Orange: on charging ; Green: fully charged
- ◆ 4 scales output voltage: **8.4V,12V,16V,19V (adjustable)**
- ◆ Output current: 3.5 ~ 4A
- ◆ USB port's output voltage/current: 5.25~5.4V / 1.2A
- ◆ Voltage Scales display: 4pcs blue LEDs
- ◆ Capacity display: 4pcs green LEDs indiate the remaining capacity.
- ◆ Output capacity: 8.4V-5.2Ahr, 12V-3.7Ahr, 16V-2.7Ahr, 19V-2.3Ahr
- ◆ With extended capacity function: It can extend the battery capacity by extended battery MP3460E from 50W to 100W.
- ◆ With pass through charging function:It can charge and power your device in the meantime,and will charge your device internal battery fully in priority,also it can charge the MP3450E from AC power adapter.
- ◆ With uninterrupted power system function:MP3450E will power your device in time while the AC power shut down to avoid your device from shutting down.

- ◆With multi-protection function:Over charge /over discharge/over current/over voltage/short circuit/over temperature protection.
- ◆Low self-discharge ,can be store 1 Years Without Using
- ◆Cycle life : 300~500 cycles
- ◆Safety Certification: CE,3C,RoHS

III. Electric specification

NO.	Item	Rated performance	Remark
1	Battery cell	Li-Polymer	
2	Battery pack's power/ Capacity	51Wh(13,600~14,000mAh)	
3	DC OUT output voltage	8.4V,12V,16V,19V	
4	Ripple voltage	≤100mV	
5	Output DC/DC transfer efficiency	94~97%	
6	DC OUT port's Power	49Wh	
7	DC OUT port's output current	3.5A(Constant),4.0A(Max.)	
8	DC OUT port's over-current protection	4.5~5A	
9	USB port's output voltage	5.25~5.4V	
10	USB port's output current	1.2A (Constant) , 1.5 A (Max.)	

11	USB port's over-current protection	2.2~3.0 A	
12	Self-discharging current	< 100uA	
13	DC IN port's charging voltage	8~20V	
14	DC IN port's charging current	800~1200mA	
15	Charging time	3~4 Hours	
16	Charging indicator	Orange: on charging , Green: fully charged	
17	DC IN port's JACK dimension	5.5~6*2.0~2.1*10.5 (inside "+",outside "-")	
18	AC Power adapter voltage/current	Same as the original AC power adapter of the Laptops	Not contained in the package
19	Solar panel charger voltage/current	12~20V/ >2000mA	the DC input jack be plug by solar panel output , it can't work on pass through charging state .
		28~35V/ 50~ 2000mA	charged by solar panel to the Capacity extended port , it can work on pass through charging state .

		12~24V/ 50~ 2000mA	The Sun-booster adapter is optional for charged by the solar panel ;the output side (3pin plug)connected to the Capacity extended port , it can work on pass through charging state .
20	Car charger voltage/current	9~15V/2.5A	1.Car charger optional accessory 2. It only for charging by car charger, it can't work on pass through charging state
21	Capacity indiation	4pcs green LEDs	
22	Voltage Scales indication	4pcs blue LEDs	
24	Pass through charging function	Firstly offer power to Laptops working and charging Laptop's internal battery . Secondly charging MP3450E battery after Laptop's internal battery charged fully .	It will stop charging while the loading current output is more than $2\pm 0.2A$ on passing through charging state.
25	Power interrupted timing for loading while AC power shut down	8 ms	When working on pass through charging state
26	The Capacity extended port function	1. connected with MP3460 for battery capacity extend to double or 2.connected with 3-pin cable connecter or sun-booster adapter for solar panel charged .	
27	Over-charge protection voltage	4.35V \pm 0.05V /cell, 26.1V \pm 0.3V/pack	

28	Over-discharge protection voltage	3.1V±0.05V/cell,18.6V±0.3V/pack	
29	Temperature protection	130℃	
30	Typical weight	420±20g	
31	Operation temperature	Charging: 0~40℃, Discharging: -10~50℃	
32	Storage temperature	1.-20~20℃(one year) 2. -20~45℃(three months) 3.-20~60℃(one month)	

IV. Operation guide –There are two situations:

1) . Indoor Application —— working for Pass through charging

- a. The connection is for passing through charging. That's to say, it not only can provide working power for your devices and charge its internal battery, but also can charge MP3450E.
- b. The charging input port must be connected with the Laptop's original AC power adapter or be replaced with another one whose output voltage/current is the same as the original one. The output voltage of DC OUT port is same as the charging voltage of DC IN port and is not controlled by Voltage Selected Switch under this state. But the Voltage Indicator still follow up the Voltage Selected Switch setting; please noted !! You can exchange original AC power adapter for another device's if not connected with Laptops.



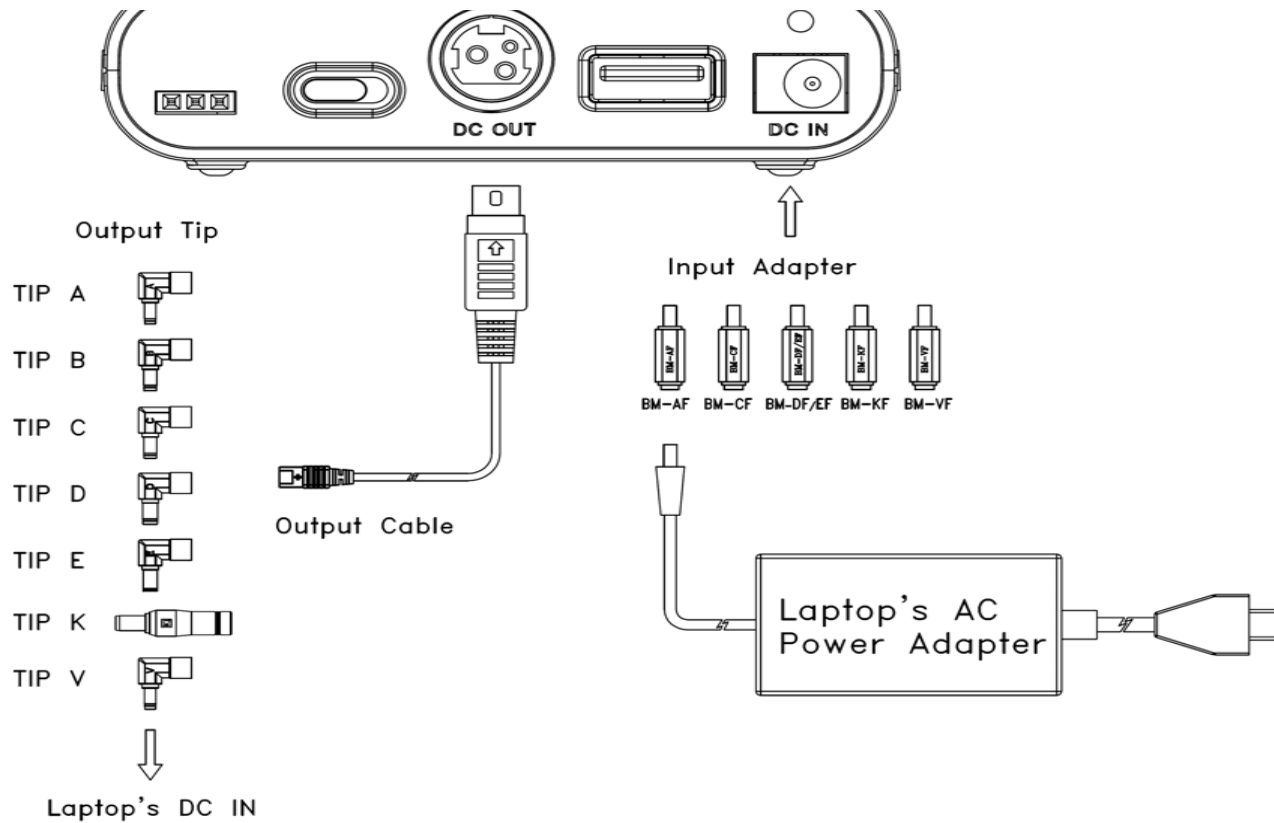

2). Outdoor application ———Back-up power for your device

- a. This connection is suitable for being used outdoors. That's to say, it's just used as back-up power for your devices. The output voltage of DC OUT port and Voltage Indicator is controlled by Voltage Selected switch setting under this state .
- b. It must set up voltage output finished before connected with laptops or another device; and can't change output voltage on working state .Otherwise will damaged connected laptops or device

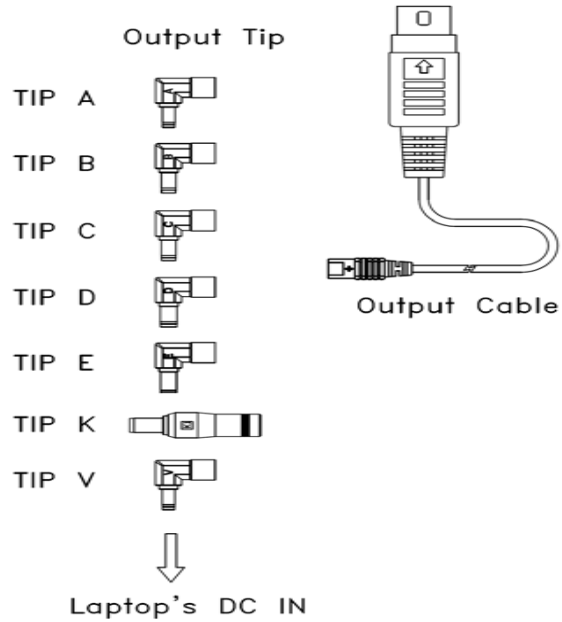
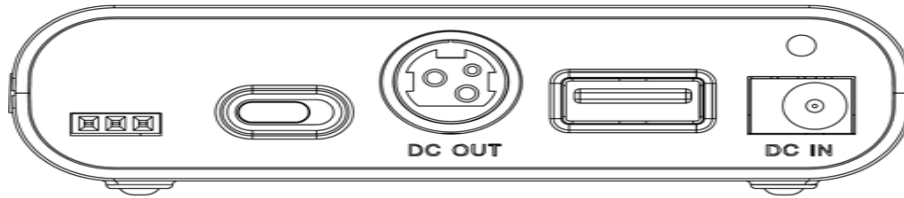

V. Charging ways

Charging main body battery capacity by 3 way :

a. Charging by AC Power Adapter

The standard package is without AC Power Adapter. Please must connected with the original AC Power Adapter of loading device.

The output plug of original AC Power Adapter of loading device is connected to DC IN port for Charging.

AC Power Adapter's specification: Must as same with Laptop's original one .

b. Charging by Car Charger

The output connecter of Car charger plug into DC IN port for charging.

The car charger is optional accessory.

Car charger's specification:

The output is directly connected to input of car charger.

- a. The input voltage/current of car charger : 9 ~14V / 2.5A
- b. The output voltage will follow up input voltage.
- c. It only can charging MP3450E by car charger. But can't apply to the pass through charging state.

C. Charging by Solar panel Charger

Due to the output's specification of Solar panel charger is different. There is 3 ways to charge by different cable & adapter plug into different port. Please check Solar panel charger specification firstly. There are 3 ways to charge as below:

Way1 : suitable for : a. The output current of solar panel : > 2A

b. The OCV voltage of solar panel : 12V ~20 V

The output connecter of solar panel charger directly plug into DC IN port

Way2 : suitable for : a. The OCV voltage of solar panel : 26V ~ 35V

b. The output current of solar panel : > 50mA

The output connector of solar panel charger plug into the DC IN of 3-pin cable; the output of 3-pin cable plug into the Capacity extended port of MP3450E. The 3-pin cable (optional accessory) diagram as below :

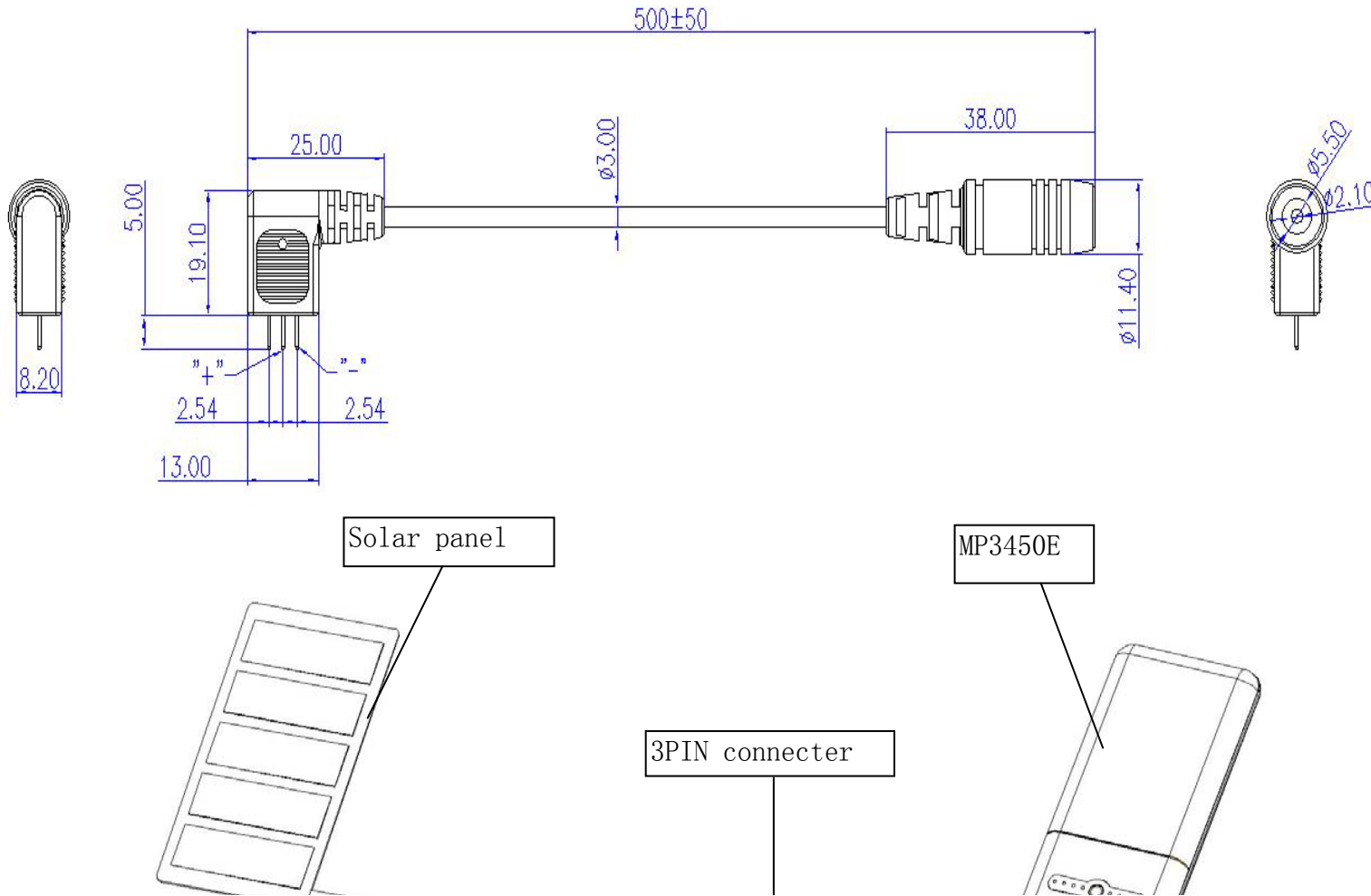

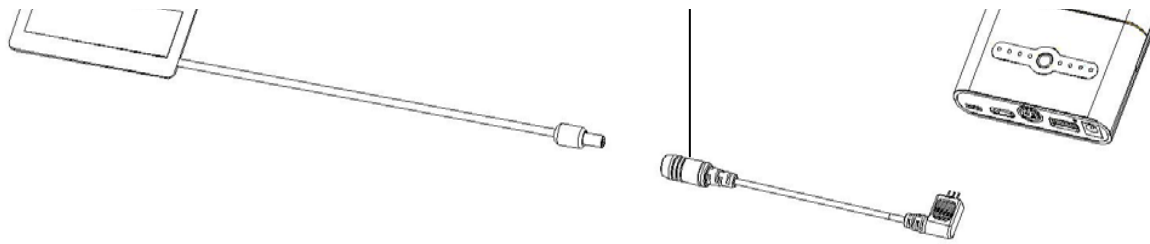

Way3 : suitable for : a. The OCV voltage of solar panel : 9V ~ 25V

b. The output current of solar panel : >100mA

The output connecter of solar panel charger plug into the DC IN Jack of 3-pin sun-booster adapter; the output of 3-pin sun-Booster adapter plug into the Capacity extended port of MP3450E. The 3-pin sun-booster adapter(optional accessory)diagram as below :

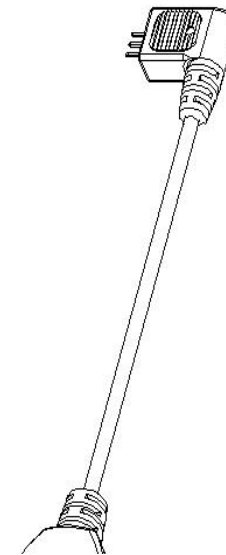
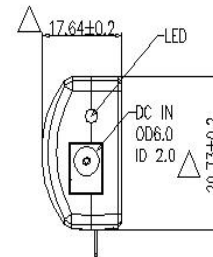
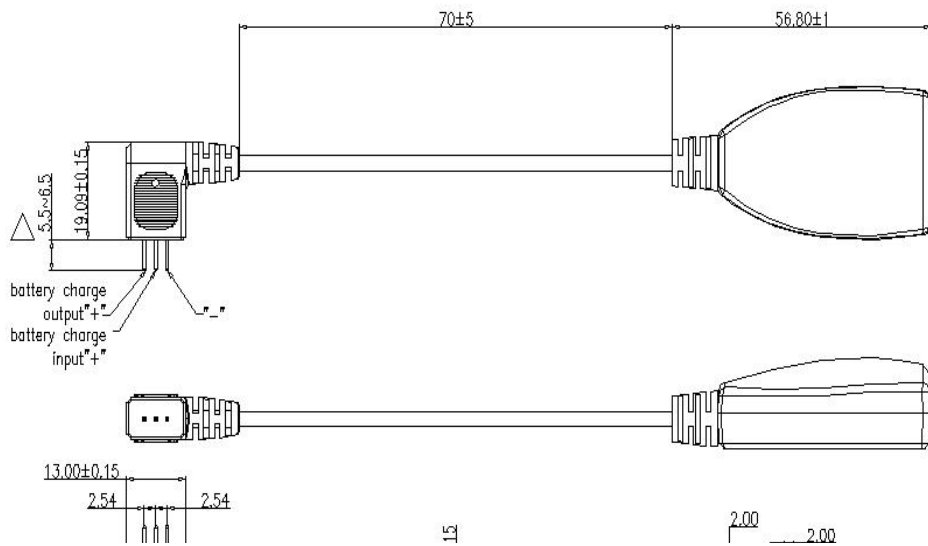

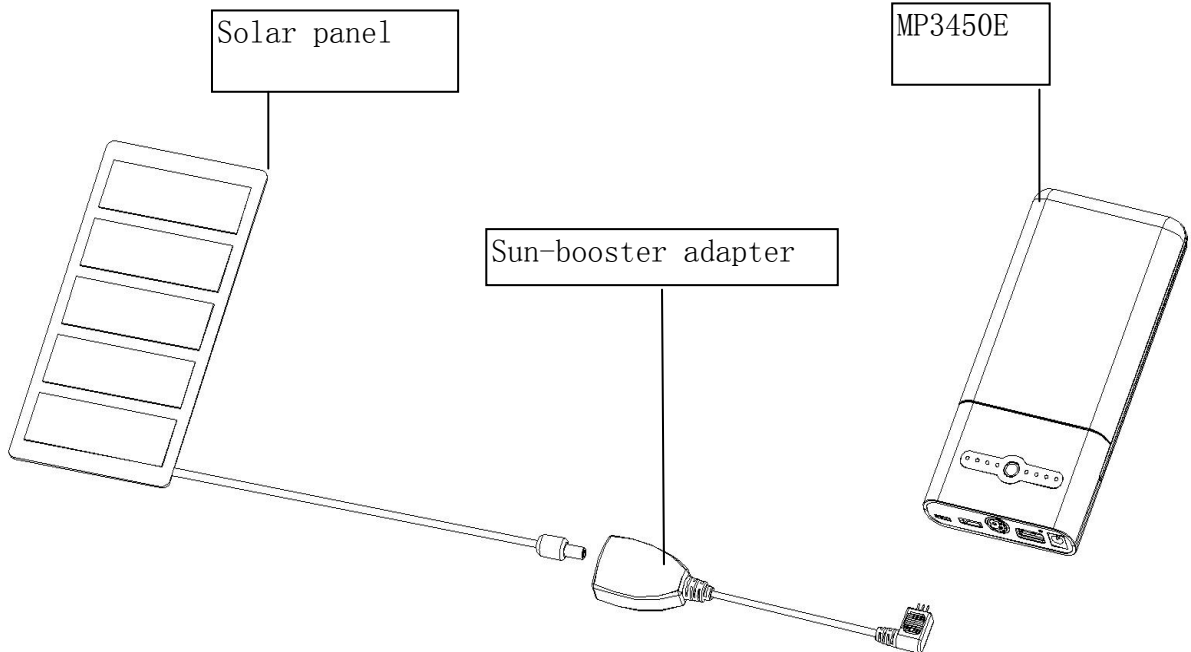
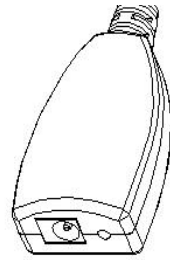
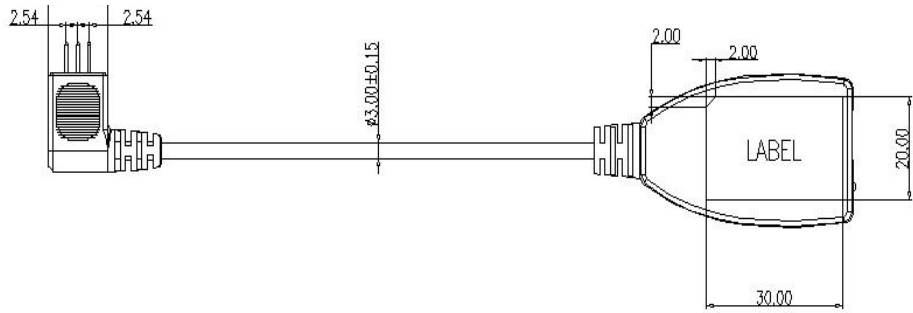

IV. Battery capacity expansion method

MP3450E can extend the battery capacity from 50W to 100W by connecting with the extra battery pack MP3460E

1. Place MP3450E on top of with both flat silver ends facing the same direction.
2. Connect the bracket with the 3-pin plugs inside to the silver ends of the devices. The 3-pin plugs will mate with the battery port on each of the device, and the controls on the end of MP3450E will show through the bracket opening.
3. Connect the second bracket on the opposite end of the devices to hold the units together securely.
4. Use MP3450E as you would normally.

MP3450E with MP3460E assemble diagram as below:

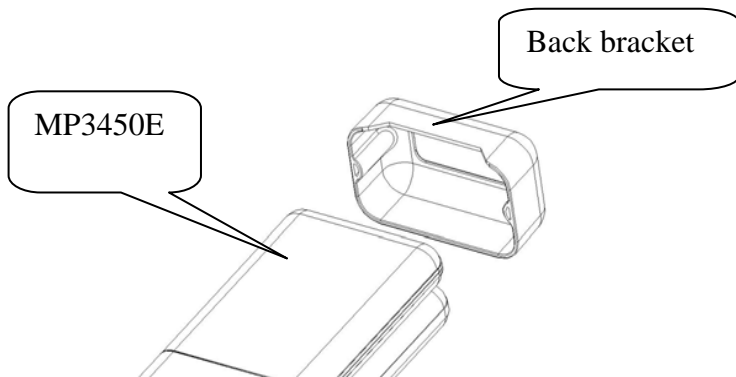

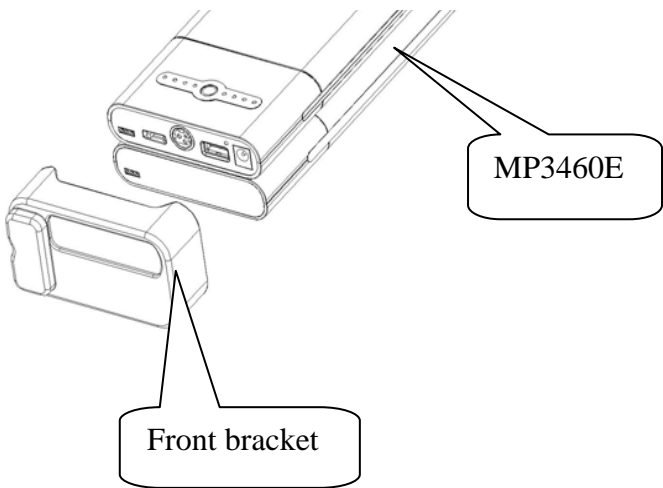

V. Product package list

1. MP3450E main body



2. Output tips



3. Input tips



4. Output cable



5. Leather case



6. Punching bag



7. User guide

