

---

# **AI SERIES ARTIFICIAL INTELLIGENCE INDUSTRIAL CONTROLLER**

## **Operation Instruction**

*Ver. 7.0*

*(Ideal for accurate controls of temperature, pressure, flow, level, humidity etc.)*

---

## CONTENTS

<b>1. SUMMARY.....</b>	<b>1</b>
1.1 MAIN FEATURES	1
1.2 ORDERING CODE DEFINITION	3
1.3 MODULES	8
1.3.1 Sockets of modules	8
1.3.2 Further descriptions about module applications	9
1.4 DIN RAIL MOUNTED INSTRUMENTS	11
1.5 TECHNICAL SPECIFICATION	13
1.6 REAR TERMINAL LAYOUT AND WIRING	16
1.7 SELECT THERMOCOUPLE REFERENCE JUNCTION COMPENSATION MODE BY USING DIFFERENT WIRING MODE	20
<b>2. DISPLAYS AND OPERATIONS .....</b>	<b>24</b>
2.1 FRONT PANEL DESCRIPTION	24
2.2 DISPLAY STATUS	25
2.3 OPERATION DESCRIPTION	27
2.3.1 Display status switch	27
2.3.2 Set Value Setting	27
2.3.3 Parameter Setting	28

---

2.4	AUTO TUNING	28
2.5	PROGRAM OPERATION (FOR AI-708P/808P ONLY)	32
2.5.1	Setup program	32
2.5.2	Run/Hold	32
2.5.3	StoP	33
2.5.4	Display and modify the running StEP NO. (StEP) of the program	33
<b>3.</b>	<b>PARAMETERS AND SETTINGS .....</b>	<b>34</b>
3.1	PARAMETER LOCK (LOC) AND FIELD PARAMETERS	34
3.2	THE FULL PARAMETER TABLE	35
3.3	ADDITIONAL REMARKS OF SPECIAL FUNCTIONS	52
3.3.1	Alarm blocking at the beginning of power on	52
3.3.2	Setpoints switch	53
3.3.3	Sectional power restriction	53
3.3.4	User defined non-linear table	54
<b>4.</b>	<b>FURTHER DESCRIPTION FOR THE OPERATION OF AI-708P/808P SERIES INSTRUMENT .....</b>	<b>57</b>
4.1	MAIN FUNCTION	57
4.2	CONCEPTS AND FUNCTIONS	58
4.3	PROGRAMMING AND OPERATION	63

## **1. SUMMARY**

### **1.1 Main Features**

- Adopt digital calibration technology for input measurement with input measurement accuracy 0.2% F.S., non-linear calibration tables for standard thermocouples and RTDs are available in the instrument.
- Adopt advanced AI artificial intelligence control algorithm, no overshoot and with the function of auto tuning and self-adaptation.
- Adopt advanced modular structure, conveniently providing plentiful output options, can satisfy the requirements of various applications, and make quick delivery and conveniences the maintenance of the instrument.
- Friendly and customized operating interface leads to easy learning and simple manipulation. Any parameter can be promoted to immediate operator access in Field Parameter Table or password protected in Full Parameter Table.
- With universal power supply of 100-240VAC or 24VDC and various installation dimensions for users to choose.
- High quality and performance hardware design, using high performance tantalum capacitor or ceramic capacitor. Compared to competing models, it consumes less electricity, experiences less temperature shifting, provides higher stability and reliability, and can work in a wider range of

temperature.

- ISO9001 and CE certified, complying with EMC requirement, achieving world class level of quality, anti-interference ability and safety.

### **POINTS FOR ATTENTION**

- This manual introduces AI-708/708P/808/808P model ARTIFICIAL INTELLIGENCE INDUSTRIAL CONTROLLER of Version 7.0. Certain functions introduced by this manual are probably not applicable for the instrument of other version. After power on, the instrument model and software version will be displayed. User should pay attention to the difference between different versions when using the instrument. Please read this manual carefully in order to use the instrument correctly and make it to its full use.
- Please correctly set parameters according to input / output specification and function. Only correctly wired instruments with parameters correctly set can be put into use.
- Compared to Version 6.5 or earlier versions, some important changes are:
  1. New rear terminal layout.
  2. New display panel with 10 LED indication lights.
  3. Heating/refrigerating dual output function, and both outputs can be either current or time proportional output.

4. Alarm applies single lateral deadband;
5. support up to 4 channel alarm or event outputs;
6. Quicker sampling speed and quicker valve control.

## 1.2 Ordering Code Definition

Advanced modularized hardware design is utilized for AI series instruments. There are maximum five module sockets: multi-function input/output (MIO), main output (OUTP), alarm (ALM), auxiliary output (AUX) and communication (COMM). The input specification can be freely set to thermocouple, RTD, or linear current/voltage.

The ordering code of AI-508 series instrument is made up of 9 parts. For example:

**AI-808**   **A**   **N**   **X3**   **L5**   **N**   **S4** — **24VDC**  
 ①   ②   ③   ④   ⑤   ⑥   ⑦   ⑧

It shows that the model of this instrument is AI-808, front panel dimension is 96×96mm, no module is installed in MIO (Multi-function I/O) socket, X3 linear current output module is installed in OUTP (main output), ALM (alarm) is L5 (dual relay contact output module), no module is installed in AUX (auxiliary output), a RS485 communication interface with photoelectric isolation is installed, and the power supply of the instrument is 24VDC.

The following is the meanings of the 8 parts:

① **Shows the model of the instrument**

**AI-708** High accuracy controller with measurement accuracy 0.2%F.S. It adopts artificial intelligent control technology, and has the functions of control, alarm, retransmission and communication.

**AI-708P** Add 30+20 segment program control to AI-708.

**AI-808** Add valve control and manual/auto control with bumpless switch to AI-708.

**AI-808P** Add 30+20 segment program control to AI-808.

② **Shows the front panel dimension.**

Model	Front Panel (width x height)	Cut-out (width x height)	Depth Behind Mounting Surface	Remarks
A(A2)	96x96mm	92x92mm	100mm	A2 has a light bar with 25 segments and 4 levels of luminosity.
B	160X80mm	152x76mm	100mm	
C(C3)	80x160mm	76x152mm	100mm	C3 has a light bar with 50 segments and 2 levels of luminosity
D	72x72mm	68x68mm	95mm	
E	48x96mm	45x92mm	100mm	

E5	48x96x110 (width x height x depth)			E5 is no panel trail mounted. It can be installed on DIN trail and programmed by connecting to external display.
F	96x48mm	92x45mm	100mm	

③ ~ ⑦ shows the module types installed on the following sockets: **MIO** (multiple input/output), **OUTP** (main output), **ALM** (alarm), **AUX** (auxiliary output), **COMM** (communication).

(“√” means the module allowed to be installed on the according socket)

Module	Module Descriptions	MIO	OUTP	ALM	AUX	COMM
<b>N</b>	no module installed	√	√	√	√	√
<b>I4</b>	4-20mA/0-20mA analogue input interface, providing a 24VDC/24mA power supply for a two-wire transmitter.	√				
<b>I5</b>	2 on-off switch signal inputs. Allow to switch setpoint between SP1 and SP2 by an external switch.	√				
<b>V5/V10/ V12/V24</b>	Isolated 5V, 10V, 12V or 24V DC output with maximum current 50mA. (use instrument's internal 24V isolated power)	√				
<b>L1</b>	1 relay contact (NO+NC) output. (big volume, 30VDC/2A, 250VAC/2A)		√	√	√	



<b>L2</b>	1 relay contact (NO+NC) output. (small volume, 30VDC/1A, 250VAC/1A)		✓	✓	✓	
<b>L4</b>	1 relay contact (NO+ NC) output. (small volume , 30VDC/2A, 250VAC/2A)		✓	✓	✓	
<b>L5</b>	2 relay contact (NO) outputs. (30VDC/2A, 250VAC/2A)		✓	✓	✓	
<b>K1</b>	Single-phase thyristor zero crossing trigger output module (can trigger one loop of a TRIAC or a pair of inverse parallel SCR with current of 5~500A)		✓		✓	
<b>K3</b>	Three-phase thyristor zero crossing trigger output module (can trigger 3-phase circuit; each channel can trigger TRIAC or a pair of inverse parallel SCR with current of 5-500A)		✓			
<b>K5</b>	Single-phase thyristor phase-shift trigger output module (can trigger one loop of TRIAC or a pair of inverse parallel SCR with current of 5-500A), suitable for 200~240VAC power supply.		✓			
<b>K6</b>	Single-phase thyristor phase-shift trigger output module, suitable for 340~415VAC power supply.		✓			
<b>X3</b>	0~20/4~20mA linear current output module. (Use internal 12VDV power of the instrument)		✓		✓	✓
<b>X5</b>	0~20/4~20mA linear current output module. (With its own isolated power)		✓		✓	✓

<b>W1</b>	TRIAC no contact normal open output. (100~240VAC/0.2A)		✓		✓	
<b>W2</b>	TRIAC no contact normal closed output. (100~240VAC/0.2A)		✓			
<b>G</b>	SSR voltage outputs (12VDC/30mA)		✓		✓	
<b>S</b>	Photoelectric isolated RS485 communication module (use instrument's internal 12V isolated power)					✓
<b>S4</b>	Photoelectric isolated RS485 communication module with its own photoelectric isolated power					✓
<b>R</b>	RS232 communication interface (use instrument's internal 12V isolated power)				✓	

⑧ shows the power supply of the instrument. If left blank, the power of the instrument is 100-240VAC. "24VDC" means the power supply of 20-32V DC or AC power supply.

**Note 1:** The instrument applies the technology of automatic zero and digital calibration, and is free of maintenance. If the error exceeds certain range, generally, cleaning and drying the inside of the instrument can fix it. If not, send the instrument back to the factory to examine and repair.

**Note 2:** Free repair and maintenance will be given in 36 months since the delivery. In order to get

full and correct repair, write the phenomena and causes of the malfunction of the instrument.

### 1.3 Modules

#### 1.3.1 Sockets of modules

AI-7 series instruments have five sockets for modules to be installed (D dimension instruments have 3 sockets: OOTP, AUX and COMM/AL1). By installing different modules, the controller can meet the requirements of different functions and output types.

- **Multiple function Input/Output (MIO):** can input signal from 2-wire transmitter or 4-20mA signal by installing I4 (current input) module. If a I2 (on-off signal input) module is installed, the instrument can switch between setpoints SV1 and SV2 by an external switch. Cooperating with OOTP and installing a K3 module can realize three-phase thyristor zero cross triggering output.
- **Main output (OOTP):** is commonly used as control output such as on-off control, standard PID control, and AI PID control. It can be also used as retransmission output of process value (PV) or setpoint (SV). Installing L1 or L4 modular can realize relay contact output; installing X3 or X5 module can realize 0-20mA/4-20mA/0-10mA linear current output; installing G module can realize SSR voltage output; installing W1 or W2 module can implement TRIAC no contact switch output.
- **Alarm (ALM):** is commonly used to be alarm output. Support 1 normal open + normal close relay output (AL1) by installing L1 or L2 module or 2 normal open relay outputs (AL1+AL2) by installing L5 module.

- **Auxiliary output (AUX):** In a heating/refrigerating dual output system, module X3, X5, L1, L4, G, W1, W2 can be installed for the second control output. It can also output alarm by installing L1, L2 or L5 module, or be used for communicating with computer by installing R module (RS232C interface).
- **Communication Interface (COMM):** Module S or S4 can be installed in for communicating with computer (RS485 communication interface), and it can also be used as power supply for external sensor when equipped with a voltage output module.

### 1.3.2 Further descriptions about module applications

- **Electric isolation of the modules:** There are a group of 24V and a group 12V power supply built in the instrument and isolated to the main circuit. The 24V power commonly supplies voltage output module, such as V24/V12/V10, I2 and I4. The 12V power is commonly supplies output or communication module. Generally, the relay contact output and TRIAC no contact discrete output are self insulated from the other circuit, no matter whether other modules are installed or not. SSR voltage output do not need to be insulated from input circuit, because SSR itself has isolation function. Therefore, only the electric isolation between the communication interface and the current output should be considered. Those modules, for example, S (RS485 communication interface), R (RS232 communication interface) and X3 (linear current output), all

need the 12V power supply. If more than one of the above modules are installed, in order to be electric isolated, only one of them can be module without electric isolation, the other modules should be S4 or X4, which has its own isolated power supply. For example, if an X module is installed in OUP (main output) socket, and an S or X module is installed in COMM (communication interface) socket, then OUP and COMM can not be electric isolated, so S or X should be replaced with S4 or X4.

- **Three-phase thyristor zero crossing trigger output module K3:** Module K3 takes OUP and MIO sockets. When K3 is installed, installing I5 on COMM socket and setting parameter “bAud” to 1 can also switch the value of setpoint.
- **Voltage output module:** The voltage output modules like V24, V10 or V12 are often used for supplying power for external transducer or feedback resistance of transmitter. These modules can be installed in any socket. To standardize the wiring, it is recommended to be installed in the first idle socket in the order of MIO, AUX, and COMM.
- **No contact triac switch module :** W1 and W2 are new types of no contact switch module which apply the advanced technology of “burn proof” and zero crossing conduction. It can replace the relay contact switch. Compared to the relay contact output module, W1 and W2 have longer life and lower interference. They can largely lower the interference spark of the equipment, and greatly improve the stability and reliability of the system. Since the driver element is TRIAC, it is

suitable for controlling 100-240VAC (not for DC power) with current up to 80A. For the current larger than 80A, an intermediate relay is needed.

- **Relay Switch Module** : the relay modules are widely used in industrial control. However, they are the only modules with life time limit and volume limit and have much electromagnetic interference. It is important to choose a suitable relay module. To control equipments with 220VAC supply, such as contactor and electromagnetic valve, W1 module is recommended. To control DC or AC below 100V, users can only use relay module. L2 module is small, and both its normal open and normal close terminals have the function of varistor spark absorption, but the capacity is small. It is suitable for alarm output. L1 and L5 have big volume and big capacity. In the 48mm dimension instrument (for example, D2, E, F and E5), only one of L1 or L5 can be installed. L5 has dual output, can be used to support two loops of alarm, for example, AL1+AL2. If you don't like mechanical switch, you can choose G5 (dual SSR voltage driver) and connect with external SSR instead.

#### **1.4 DIN Rail Mounted Instruments**

DIN rail mounted instrument (dimension E5) has no display window. It is often operated by communicating with host computer through a RS485 communication interface.

The address and baud rate parameters can be set by the instrument's internal switch. There is

a switch of 10 bits behind the front cover of the instrument. The bit 1~7 is a binary number from 0 to 100 indicating the communication address. The eighth bit indicates baud rate, “0” means baud rate is set to 9600, and “1” for 19200. The other two bits is spare for future use. The updated parameters won’t be active until the instrument power on again.

E5 dimension instrument has one LED indication light. When the instrument is communicating with the host computer, the light flashes with light on time different to light off time. When the instrument hasn’t received signal from the host computer for 6 seconds, the indication light should flash with the same light on time and light off time. The flash frequency can tell the work status of the instrument:

That the on-off period is as long as 1.6 second means no communication and no alarm (it can be treated as normal);

The light flashing with period 0.6 second means no communication and general error occurs.

The light quickly flashing with period 0.3 second means no communication and severe error such as input over range occurs.

The light keeping off means the instrument power off or damaged; the light keep on (longer than 8 seconds) means the instrument is on but is damaged.

The parameters of E5 dimension instrument can also be set by connecting ADP1 display to the 1394 socket.

Note: The 1394 socket of the instrument only supports Yudian ADP1 display.

### 1.5 TECHNICAL SPECIFICATION

- **Input type: (Any of below specifications can be selected by parameter “Sn”)**

Thermocouple: K, S, R, T, E, J, N, WRe3-WRe25, WRe5-WRe26

Resistance temperature detector: Cu50, Pt100

Linear voltage: 0~5V, 1~5V, 0~1V, 0~100mV, 0~60mV, 0~20mV, etc.; 0~10V if module I31 is installed on MIO socket.

Linear current (external connect to precise shunt resist or install I4 module on MIO): 0~20mA, 4~20mA, etc.

Linear resistance : 0~80ohm, 0~400ohm.

Optional: apart from the above-mentioned Input type, an additional type can be provided upon request. (Graduation index is needed)

- **Instrument Input range**

K(-100~1300°C), S(0~1700°C), R(0~1700°C), T(-200~+390°C), E(0~1000°C), J(0~1200°C),



B(600~1800℃), N(0~1300℃), WRe3-WRe25(0~2300℃), WRe5-WRe26(0~2300℃)

Cu50(-50~+150℃), Pt100(-200~+800℃)

Linear Input: -9990~30000 defined by user.

- **Measurement accuracy** : 0.2%FS ± 0.1℃
- **Resolution** : 0.1℃ (automatically change to 1℃ when the temperature is high than 999.9℃) or 1℃ selectable
- **Temperature drift** : ≤0.01%FS /℃ (typical value is 50ppm/℃)
- **Response time** : ≤0.3s ( when digital filter parameter dL=0)
- **Control mode:**
  - On-off control mode (deadband adjustable)
  - AI MPT with auto tuning, adopting fuzzy logic PID algorithm.
- **Output mode (modularized)**
  - Relay output (NO+NC):** 250VAC/2A or 30VDC/1A
  - TRIAC no contact discrete output (NO or NC):** 100~240VAC/0.2A (continuous), 2A (20mS instantaneous, repeat period ≥5s)
  - SSR Voltage output:** 12VDC/30mA (used to drive SSR).
  - Thyristor zero crossing trigger output:** can trigger TRIAC of 5~500A, a pair of inverse paralleled SCRs or SCR power module.

**Linear current output:** 0~20mA, 4~20mA (The output voltage of X module  $\geq 10.5V$ ; and that of X3 module  $\geq 10.5V$ .)

- **Electromagnetic compatibility (EMC)** :  $\pm 4KV/5KHz$  according to IEC61000-4-4; 4KV according to IEC61000-4-5.
- **Isolation withstanding voltage** : between power, relay contact or signal terminal  $\geq 2300VDC$ ; between isolated electroweak terminals  $\geq 600VDC$
- **Power supply** : 100~240VAC, -15%, +10% / 50-60Hz; 120~240VDC; or 24VDC/AC, -15%, +10%.
- **Power consumption:**  $\leq 5W$
- **Operating Ambient** : temperature  $-10\sim 60^{\circ}C$ ; humidity  $\leq 90\%RH$
- **Front panel dimension:** 96×96mm, 160×80mm, 80×160mm, 48×96mm, 96×48mm, 48×48mm, 72×72mm
- **Panel cutout dimension:** 92×92mm, 152×76mm, 76×152mm, 45×92mm, 92×45mm, 45×45mm, 68×68mm
- **Depth behind mounting surface:** 100mm

## 1.6 Rear Terminal Layout and Wiring

Wiring graph for instruments except D and D2 dimension.

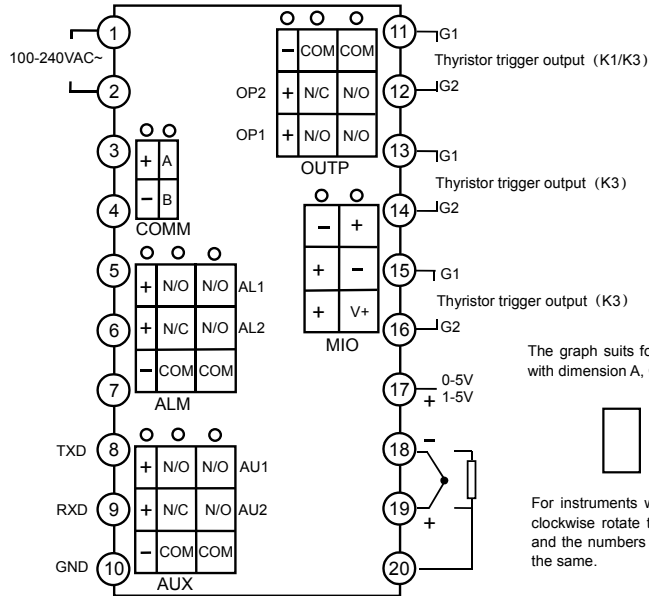

The graph suits for upright instruments with dimension A, C or E

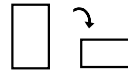

For instruments with dimension F, just clockwise rotate the graph 90 degree, and the numbers of the terminals keep the same.

Note 1: For linear voltage input, if the range is below 1V, connect to terminals 19 and 18. 0~5V or 1~5V signal can be inputted from terminals 17 and 18.

Note 2: 4~20mA linear current signal can be transformed to 1~5V voltage signal by connecting a 250 ohm resistor, and then be inputted from terminals 17 and 18. If I4 module is installed in MIO socket, 4~20mA signal can be inputted from terminals 14+ and 15-, and 2-wire transmitter can be inputted from terminals 16+ and 14-.

Note 3: The compensation wires for different kinds of thermocouple are different, and should be directly connect to the terminals. When the internal auto compensation mode is used, connecting the common wire between the compensation wire and the terminals will cause measurement error.

### Wiring graph of D dimension instruments (72×72mm)

Note 1: Linear voltage signal of range below 1mV should be inputted from terminals 13 and 12, and signal of 0~5V and 1~5V should be inputted from terminals 11 and 12.

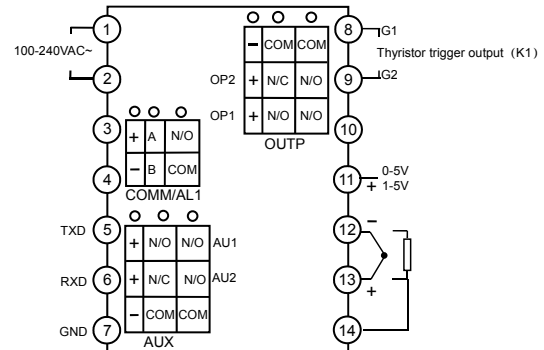

Note 2: 4~20mA linear current signal can be converted to 1~5V voltage signal by connecting a 250 ohm resistor and inputted from terminals 11 and 12.

Note 3: S or S4 module can be installed in COMM socket for communication. If relay, TRIAC no contact switch, or SSR driver voltage output module is installed in COMM, it can be used as alarm output. If I2 module is installed in COMM and parameter “bAud” is set to 1, then on-off signal can be inputted, and SV1 and SV2 can be switched by connecting a switch between terminals 3 and 4.

**Wiring graph of thyristor trigger output is as below (suitable for module K1, K3, K5 and K6):**

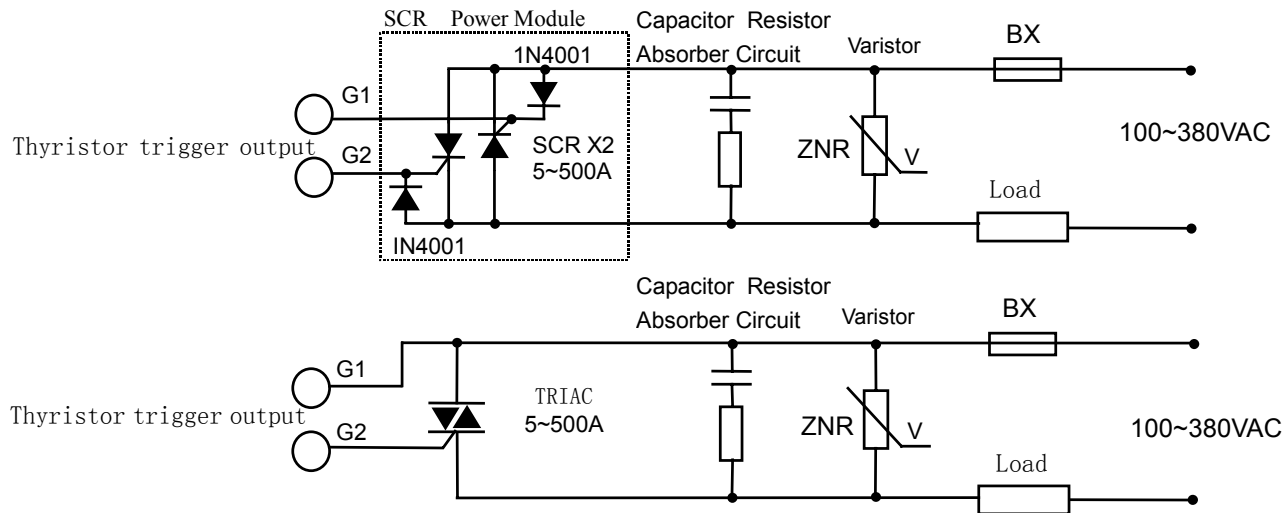

Note 1: According to the voltage and current of load, choose suitable varistor to protect the thyristor. Capacitor resistor absorber is needed for inductance load or phase-shift trigger output.

Note 2: SCR power module is recommended. A power module includes two SCRs, is similar to the above dashed square.

Note 3: Phase-shift trigger module K5 only supports 200~240VAC power, and K6 supports 340~415VAC.

### **1.7 Select thermocouple reference junction compensation mode by using different wiring mode**

Reference junction compensation is needed junction for thermocouple input. AI instrument supply good reference junction compensation for thermocouple input through 4 different compensation modes selective using software configuration and different external wiring.

- **Internal automatic compensation:** this is the default mode, and can satisfy a lot of industrial application. But because temperature sensor is installed inside the instrument or at wiring terminals, and may be easily affected by the heat generated in the instrument and by compensating lead wire connection and surroundings, measurement error may be produced up to 2—4°C sometimes.
- **Compensation with Cu50 copper resistor sensor externally connected:** the compensation precision is high. In the application in which high measurement precision is needed, you can buy

a Cu50 copper resistor and had better prepare an external wiring box, and then put the copper resistor together with thermocouple reference junction far away from exothermic object. Compensation error is less than  $0.5^{\circ}\text{C}$  for this mode.

- **Thermostat compensation:** If we replace Cu50 by an accurate resistor, thermostat compensation is available. For example, a resistance of  $60\ \Omega$  is installed, we can get the compensate temperature of  $46.6^{\circ}\text{C}$  by looking up into the Cu50 graduation index, and then put the thermocouple reference junction into thermostat of  $46.6^{\circ}\text{C}$ . The compensation precision is higher than copper resistor compensation.
- **Ice point compensation:** It is necessary to put thermocouple reference junction (where thermocouple lead wire connect with common lead wire) into ice-water mixture the compensation precision is very high, with reference junction compensation error less than  $0.1^{\circ}\text{C}$  if ice point and compensation lead wire is guaranteed.



**Wiring diagrams for the above compensation modes:**

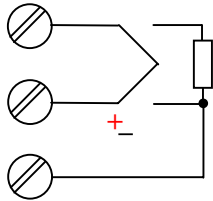

**Corresponding wiring diagram of the instrument**

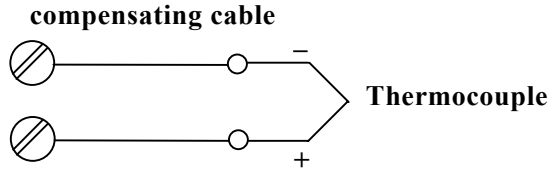

**(1) Internal automatic compensation connected**  
(compensating cable directly connected to instrument's terminals)

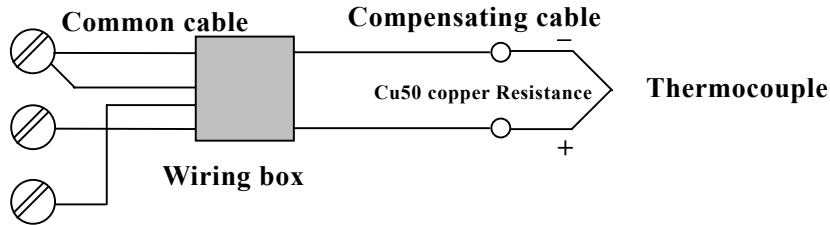

**(2) Automatic compensation mode by externally connected copper resistance**

*Note: wiring box should be well way from the heat generating object.*

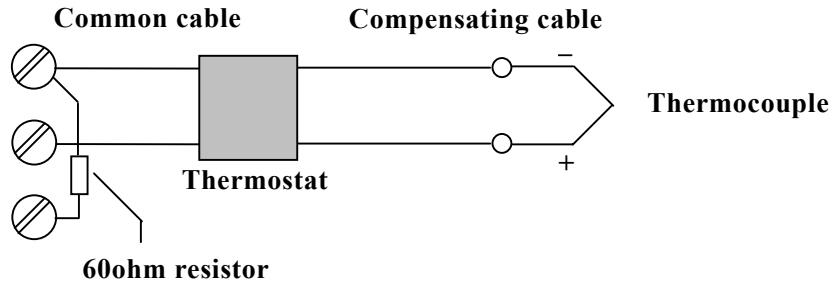

**(3) fixed temperature compensation mode**

*Note : the temperature of thermostat should be controlled at 46.6 °C*

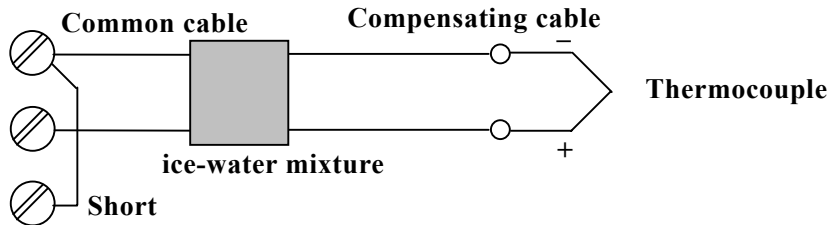

**(4)ice point compensation mode**

## 2. DISPLAYS AND OPERATIONS

### 2.1 Front Panel Description

- ① Upper display window, displays PV, parameter code, etc.
- ② Lower display window, displays SV, parameter value, or alarm
- ③ Setup key, for accessing parameter table and conforming parameter modification.
- ④ Data shift key, and auto/manual control switch.
- ⑤ Data decrease key
- ⑥ Data increase key
- ⑦ 10 LED indicators.

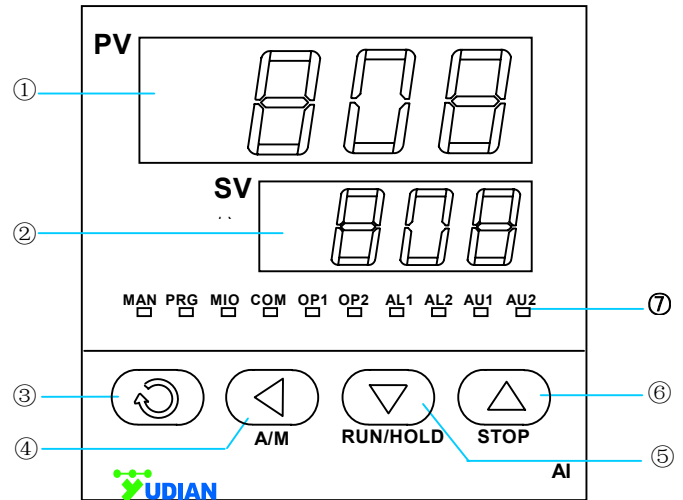

## 2.2 Display Status

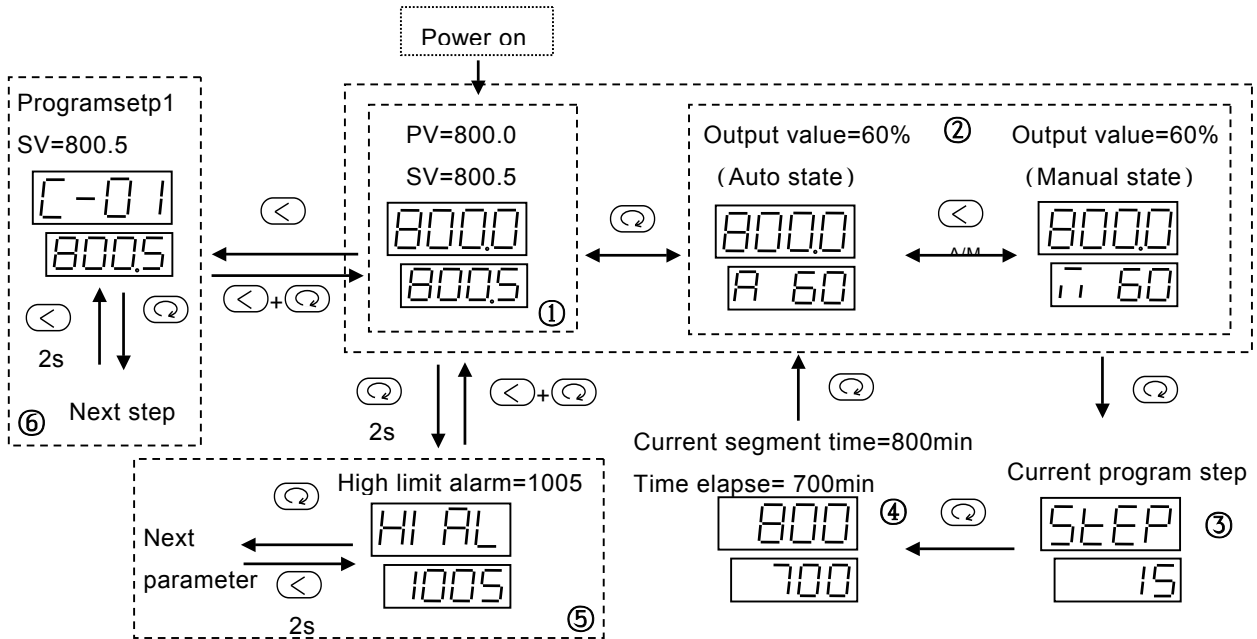

**Note:** Not all models have the above display status. AI-708 has status ① and ⑤; AI-808 has ①, ② and ⑤; AI-708P has ①, ③, ④, ⑤ and ⑥; and AI-808P has all above status.

**Basic display status :** When power on, the upper display window of the instrument shows the process value (PV), and the lower window shows the setpoint (SV). For AI-808/808P, pressing  can switch between status ① and ②. Status ① and ② are called basic display status.

When the input signal is out of the measurable range (for example, the thermocouple or RTD circuit is break, or input specification sets wrong), the lower display window will alternately display “orAL” and the high limit or the low limit of PV, and the instrument will automatically stop control and set output to 0.

If the lower display window alternately display “HIAL”, “LoAL”, “HdAL” or “LdAL”, it means high limit alarm, low limit alarm, deviation high alarm, and deviation low alarm occurs. The alarm display can also be turned off by setting parameter “cF”.

For program type instruments AI-708P/808P, the lower display may alternately display between SV and “StoP”, “HoLd”, or “rdy” which means the program control is stop, pause and ready.

There are 8 indication light on the front pannel. Light “MAN” on means manual output status, and off means auto control status. “PRG” on indicates program control status, flashing means that the program is in that status of hold or ready, and off means the program stops. MIO, OP1, OP2, AL1, AL2, AU1 and AU2 respectively indicate I/O operation of the corresponding module. For example,

That the COMM indicator is lighting means that the instrument is communicating with computer.









When current module X or X4 is installed on OOTP socket, the brightness of OP1 and OP2 indicates the magnitude of the current. When K5 single phase shifting module is installed on OOTP sockets, OP2 on indicates that the external power is on, and the brightness of OP1 shows the magnitude of phase-shifting trigger output.

## **2.3 Operation Description**









### **2.3.1 Display status switch**



Depending on the instrument model, press  key can switch between different display status. AI-808 can switch between status ① and ②; ①, ③ and ④ for AI-708P; and ①, ②, ③ and ④ for AI-808P.

### **2.3.2 Set Value Setting**



In basic display status, if the parameter lock “Loc” isn't locked, we can set setpoint (SV) by pressing ,  or . Press  key to decrease the value,  key to increase the value, and  key to move to the digit expected to modify. Keep pressing  or , the speed of decreasing or inscreasing value gets quick. The range of setpoint is between the parameter SPL and SPH. The default range is 0~400.

### 2.3.3 Parameter Setting

In basic display status, press  and hold for about 2 seconds can access Field Parameter Table. Pressing  can go to the next parameter; pressing ,  or  can modify a parameter. Press and hold  can return to the preceding parameter. Press  (don't release) and then press  key simultaneously can escape from the parameter table. The instrument will escape automatically from the parameter table if no key is pressed within 30 seconds, and the change of the last parameter will not be saved.

In Field Parameter Table, press  till the last field parameter "Loc" appears. Setting Loc=808 and then press  can access System Parameter Table.

## 2.4 Auto Tuning

When artificial intelligence MPt control or standard PID control is chosen (Ctrl=2), the parameter M5, P, and t can be obtained by running auto-tuning. In basic display status, press  for 2 seconds until "At" flashes in lower window, and the instrument executes on-off control. After 2 cycles of on-off action, the instrument will obtain the values of MPt control parameters. If you want to escape from auto tuning status, press and hold  for about 2 seconds until the "At" disappears. Change "At" from "on" to "oFF", press  to confirm, then the auto tuning process will be cancelled.

After the auto tuning is finished, the instrument will set parameter Ctrl to 3 (factory set is 1) or 4, and now it is not allowed to start up auto tuning by pressing  key on front panel. This will avoid repeat auto tuning by mistake.

If the setpoint value is different, the parameter obtained from auto tuning will not always be the same. So if you want to execute auto tuning, you must adjust setpoint to an often-used value first (For AI-708P/808P, set the value of the current program step to the often-used value), and then start up auto tuning function. Parameter Ctl and dF have influence on the accuracy of auto-tuning. Theoretically, the smaller for these two parameters setting value, the higher for the precision of auto tuning. But dF parameter value should be large enough to prevent the instrument from error action around setpoint due to the oscillation of input. Normally, parameters are recommended to be Ctl=0-2, dF=0.3 (dF=0.8 for AI-708T).

On the basis of disturbance caused by on-off control, oscillation period, amplitude and waveform are analyzed to calculate optimum control parameters. The auto tuning for AI series instrument will gratify for 90% users. Due to the complexity of the automatic process, parameters calculated by auto tuning are probably not the optimal values on some special occasion (mentioned as follows).

- An electric furnace heated up by stages, and the stages may interact each other, then the value of parameter M5 may be on the high side of its optimal value.
- Long lagged process.



- Quick responded physical quantity (flow and certain pressure) controlled by the slow valve, then the value of parameter P, t may on the high side of their optimal value. Manual tuning can get better effect.
- When some mechanical contact such as contactor or solenoid valve are used for control and parameter Ctl is set too big.
- It is not easy to get optimal M5 parameter in refrigerating system and non-temperature system such as pressure, flow, etc. So set M5 by its definition that M5 is the change of the measurement value when output change 5%.
- Other special system such as nonlinear system and time varying system.

If optimal parameters can't obtain by auto tuning, M5, P, t parameters can be manually adjusted. During manual parameter adjustment, response curve of the system should be observed carefully.

- If it is short period oscillation (oscillation period is similar to the oscillation of auto tuning), you can decrease P (first), or increase the value of parameter M5 and t.
- If it is long period oscillation (oscillation period is several times of the oscillation of auto tuning), you can increase the value of parameter M5 (first), P and t.
- None oscillation but too severe steady-state error, you can decrease M5 (first) and increase P.
- If it must cost a long period of time to obtain stable control, you should decrease t (first), M5 and

increase P.





Another method can be used in the parameter adjustment. Increase or decrease one of the MPT parameters (M5, P or t) by the range of 30%-50%, if the control effect is improved then go on, or else, do the opposite operation. In generalized case, parameter M5 should be modified first, and then modify the parameter P, t and Ctl in turn.

#### Manual auto tuning (AI-808/808P only)



On-off control is adopted when auto tuning is executing, and the output will be positioned at the position defined by parameter "oPL" and "oPH". On some applications in which some executive bodies such as control valve is used and therefore outputs are not allowed to be greatly changed, traditional auto tuning is not suitable. AI-808 series instruments have manual auto tuning mode, to do this, switching the instrument to manual mode at first, then start up auto tuning at manual mode after manual control is basically stable. After doing so, the output will be restricted in the range defined by the current manual output +10% and -10%, not by "oPL" and "oPH". When the controlled object is fast responding physical quantity, manual auto-tuning can obtain better result. Note: before manual auto-tuning, the manual output value should be limited in the range of 10% - 90%, otherwise optimal parameters can be obtained.

## 2.5 Program operation (for AI-708P/808P only)



### 2.5.1 Setup program

Press the key  once and release in the display status ①, the instrument will be in the setup program status. The setpoint of the current program StEP will be displayed. Pressing ,  or c can modify the value. Pressing  can go to next parameter. The program parameters will be displayed in the sequence of setpoint1, time1, setpoint2, time 2, etc... Pressing  and holding for about 2 seconds will return to the previous parameter.



### 2.5.2 Run/Hold

In display status ①, if the program is in stoP status ("StoP" is alternately displayed on the lower window), press and hold the  key for about 2 seconds until the lower display window displays the "Run" symbol, the instrument then will start the program. At running status, press and hold the  key for about 2 seconds until the lower display window displays the "HoLd" symbol, the instrument changes to hold status. At Hold status, the program is still executing, and the process value is control led around the setpoint, but the timer stop working, and the running time and setpoint remains. At Hold status, press and hold the  key for about 2 seconds until the lower display window displays the "Run" symbol, the instrument then restart.

### 2.5.3 StoP

Press and hold the  key for about 2 seconds in the display status  until the lower display window displays the "stoP" symbol, the stoP operation is executed now. This operation forces the instrument to stop running, and the StEP number is reset to 1, the event output is cleared, the control output is also stopped.

### 2.5.4 Display and modify the running StEP NO. (StEP) of the program

Some times it is expected that the program begin with a certain StEP, or jump directly to one StEP and execute from there. For example, when the current program reaches the 4th StEP but the user wants to finish the StEP in advance and execute the 5th StEP, then press  to switch to program step display status (display status ) and modify the program StEP number. If the StEP number is manually changed, the running time will be cleared to 0 and program will start from the beginning of the new StEP. If the StEP number is not changed, pressing  will escape the program step setting status, and will not affect the program running.

### **3. PARAMETERS AND SETTINGS**

#### **3.1 Parameter Lock (Loc) and Field Parameters**

In order to protect important parameters from being modified by mistake, but also offer enough flexibility for field control, parameter lock (Loc) and field parameters are introduced.

The parameters need to be displayed and modified in the work field are called Field Parameters. The set of field parameters is a subset of the full parameter set, and can be freely chosen by the user . User can select up to 8 filed parameters through parameter EP1~EP8.

Loc can authorize different security privilege. For details, please read the description of parameter “Loc” in the full parameter table. Setting Loc=808, and then pressing  to confirm, can enter the full parameter table and modify all parameters.

### 3.2 The Full Parameter Table

Code	Name	Description	Setting Range
<b>HIAL</b>	High limit alarm	Alarm is triggered when PV (Process Value) >HIAL; alarm is released when PV<HIAL-dF; To disable high limit alarm, set HIAL=9999 Alarm action output can be defined by parameter ALP.	-1999~ +9999 units or 1 °C
<b>LoAL</b>	Low limit alarm	Alarm triggered when PV<LoAL; alarm released when PV>LoAL+dF Set LoAL =-1999 can disable low limit alarm	
<b>dHAL</b>	Deviation high alarm	Alarm triggered when PV-SV>dHAL; alarm released when PV-SV<dHAL-dF Set HdAL=9999 can disable deviation high alarm.	0~9999 units or 0~999.9 °C
<b>dLAL</b>	Deviation low alarm	Alarm triggered when SV-PV>dLAL; alarm released when SV-PV<dLAL-dF NEED DEL >>>>>>(For on-off control, HdAL and LdAL can also be used as the second high limit and low limit alarms. (Refer to the description of parameter AF))	
<b>dF</b>	Alarm hysteresis	Avoid frequent alarm on-off action because of the fluctuation of PV	0~2000 units or 0.1°C

<b>Ctrl</b>	Control mode	<p>0: on-off control. For situation not requiring high precision;</p> <p>1: AI MPt control. Allowed to quick activate auto-tuning (pressing  in basic display status.)</p> <p>2: AI MPt control. Activate auto-tuning.</p> <p>3: After auto-tuning finished, the instrument automatically set Ctrl=3, and quick auto-tuning function is disabled.</p> <p>4: Comparing with the control mode of Ctrl=3, Parameter P is defined as 10 times as its original value. Ex., if set P=5 incase of Ctrl=3 and set P=50 incase of Ctrl=5, then these 2 setting have then same control effect. In the application of rapidly changed temperature (changes by more than 100°C/second), pressure or flow control, or in the application where inverter is used to control water pressure, P is often very small, even smaller than 1. If Ctrl is set to 4, then parameter P can be enlarged 10 times, and so finer control is obtained.</p>	0~4
<b>M5</b>	Hold parameter	<p>Parameter M5, P, t, Ctl etc. are only for AI MPt control, and have no effect to on-off control.</p> <p>M5 is defined as measurement variation after output is changed by 5% (0.5mA if OP1=1) and when controlled process is basically stabilized. "5" indicates that output variation is 5 (5% or 0.5mA). Generally M5 parameter of the same system will changes with measurement value, and so M5 parameter should be configured with process value around operating point.</p>	0~9999 units or 0~999.9 °C

		<p>Take temperature control of electric furnace as an example, the operating point is 700°C. To find out optimum M5 parameter, assuming that when output remains 50%, the temperature of electric furnace will finally be stabilized at 700°C, and when output changes to 55%, the temperature will finally be at 750.</p> <p>Then M5 (optimum parameter)=750-700=50 °C. M5 parameter mainly determines the degree of integral function, similar as integral time of PID control. The smaller M5 parameter is, the greater integral function is; where the larger M5 parameter is, the smaller integral function is (integral time is increased). But if M=0, then integral function an artificial intelligence control function will be removed and the instrument is turned to be an PD adjustment that used as a secondary controller during cascade control.</p>	
<b>P</b>	rate parameter	<p>P is in reverse proportion to measurement variations caused by output changes by 100% in one second. It is defined as the following: if Ctrl=1 or 3, then <math>P=1000/\text{measurement variation per second}</math>, the unit is 0.1°C or 1 defined unit.</p> <p>Ex., instrument use 100% power to heat and there is no heat loss, if temperature increase 1°C each second, then <math>P=1000/10=100</math>. If Ctrl=4, then P parameter will be configured by increasing 10 times. Ex., P should be set to 1000 in the above example.</p> <p>P is used to control proportional and derivative function in direct</p>	0~9999 seconds



		proportion. Decreasing P parameter will decrease proportional and derivative function. P parameter does not affect integral function.	
<b>t</b>	Lag time parameter	<p>Parameter t is applied as one of the important parameters of AI artificial intelligence control algorithm. "t" is defined as follows: time needed for a electric furnace from the beginning of elevating temperature to get to 63.5% against the final speed of temperature elevating, provided there is no heat loss. The unit of parameter "t" is second.</p> <p>For industrial control, hysteresis effect of the controlled process is an important factor impairing control effect. The longer is system lag time, the more difficult to get ideal control effect. Lag time parameter "t" is a new introduced important parameter for AI artificial intelligence algorithm. AI series instrument can use parameter "t" to do fuzzy calculation, and therefore overshoot and hunting do not easily occurs and the control have the best responsibility at the time.</p> <p>The optimal t equals to derivative time in PID control. Parameter "t" gives effect on proportional, integral and derivative function. If <math>t \leq Ctl</math>, derivative function of system will be eliminated.</p>	0~2000 seconds
<b>Ctl</b>	Control period	<p>Small value can improve control accuracy.</p> <p>For SSR, thyristor or linear current output, generally 0.5~3 seconds.</p> <p>For Relay output or in a heating/refrigerating dual output control system, generally 15 to 40 seconds, because small value will cause the frequent</p>	0~125 x0.5 seconds

		on-off action of mechanical switch or frequent heating/refrigerating switch, and shorten its service life. Ctl is recommended to be 1/4 – 1/10 of lag time t, and not greater than 60 seconds.				
<b>Sn</b>	Input specification Code	<b>InP</b>	<b>Input spec.</b>	<b>InP</b>	<b>Input spec.</b>	0~37
		<b>0</b>	K	<b>20</b>	Cu50	
		<b>1</b>	S	<b>21</b>	Pt100	
		<b>2</b>	R	<b>22</b>	0~75mV	
		<b>3</b>	T	<b>26</b>	0~80ohm resistor input	
		<b>4</b>	E	<b>27</b>	0~400ohm resistor input	
		<b>5</b>	J	<b>28</b>	0~20mV voltage input	
		<b>6</b>	B	<b>29</b>	0~100mV voltage input	
		<b>7</b>	N	<b>30</b>	0~60mV voltage input	
		<b>8</b>	WRe3-WRe25	<b>31</b>	0~1V voltage input	
		<b>9</b>	WRe5-WRe26	<b>32</b>	0.2~1V voltage input	
		<b>10</b>	extended input specification	<b>33</b>	1~5V voltage input	
		<b>12</b>	F2 radiation type pyrometer	<b>34</b>	0~5V voltage input	
		<b>15</b>	4~20mA (installed I4 in MIO)	<b>35</b>	-20~+20mV	
<b>16</b>	0~20mA (I4 is installed in MIO)	<b>36</b>	2~10V			
	0~10V (I31 is installed in MIO)	<b>37</b>	0~20V			

<b>dIP</b>	Radix point position	<p>Four formats (0, 0.0, 0.00, 0.000) are selectable  dIP=0, display format is 0000, no radix point  dIP=1, display format is 000.0  dIP=2, display format is 00.00  dIP=3, display format is 0.000</p> <p>Note 1: For thermocouples or RTD input, only 0 or 0.0 is selectable, and the internal resolution is 0.1.  dIP only affect the display, and has no affect to the accuracy of measurement or control.</p>	0~3
<b>dIL</b>	Signal scale low limit	Define scale low limit of input. It is also the low limit of external set value, transmission output and light bar display.	-1999~ +9999 units or 1 °C
<b>dIH</b>	Signal scale high limit	Define scale high limit of input. It is also the high limit of external set value, retransmission output and light bar display.	
<b>Sc</b>	Input offset	<p>Sc is used to compensate the error caused by transducer, input signal, or auto cold junction compensation of thermocouple.</p> $PV\_after\_compensation = PV\_before\_compensation + Sc_b$	-1.99~ +400.0 °C
<b>OPT</b>	output type	<p>Opt select the control output type:  <math>OPT = OPT.A \times 1 + OPT.B \times 10</math></p> <p>OPT.A shows the output type of OUP. It should be compatible with the module installed in OUP sockets.</p> <p><b>oPt.A=0</b>, if output modules such as SSR voltage output, relay contact discrete output, thyristor cross zero trigger output, and TRIAC</p>	0~48

		<p>no-contact discrete output are installed in OOTP.</p> <p><b>OPt.A=1</b>, 0 ~ 10mA linear current output. Linear current output module should be installed to main output.</p> <p><b>OPt.A=2</b>, 0 ~ 20mA linear current output. Linear current output module should be installed to main output.</p> <p><b>OPt.A=3</b>, spare</p> <p><b>OPt.A=4</b>, 4 ~ 20mA linear current output. Linear current output module should be installed to main output.</p> <p><b>OPt.A=5~8</b>, (for AI-808/808P only), position proportional output, used for valve rotation control. Outputs from OP1 and OP2 ports can directly control valve's direct and inverse rotation.</p> <p>OPt.A=5, no valve feedback, and the valve execution time should be greater than 60 seconds.</p> <p>OPt.A=6, valve feedback signal can be inputted from 0~5V input terminals. The valve execution time should be greater than 10 seconds.</p> <p>OPt.A=7, execute valve auto-tuning. After the auto-tuning finished, OPt.A will be automatically set to 6.</p> <p><b>OPt.A=8</b>, single channel phase-shift output. K5 module should be installed.</p> <p>When OPt.A=5~8, AUX can not work as refrigerating output.</p>	
--	--	---	--

		<p>OPt.B shows the AUX output type. It works only when parameter oPL&lt;0.</p> <p><b>OPt.B=0</b>, time proportional output. Output modules such as SSR voltage output, relay contact discrete output, thyristor cross zero trigger output, and TRIAC no-contact discrete output can be installed in OUPt.</p> <p><b>OPt.B=1</b>, 0~10mA linear current output. Linear current output module should be installed to main output.</p> <p><b>OPt.B=2</b>, 0~20mA linear current output. Linear current output module should be installed to main output.</p> <p><b>OPt.B=3</b>, spare</p> <p><b>OPt.B=4</b>, 4~20mA linear current output. Linear current output module should be installed to main output.</p> <p>AUX does not support position proportional output or phase-shift trigger output.</p> <p>For example, OUT and AUX all output 4~20mA linear current, then OPt=44.</p>	
<b>OPL</b>	Output low limit	<p>0~110%: OPL is the minimum output of OUPt in single directional control system.</p> <p>-110~-1%: the instrument works for a bidirectional system, and has heating/refrigerating dual output. When CF.A=0, OUPt (main output) works for heating, and AUX (Auxiliary output) works for refrigerating. When CF.A=1, OUPt works for refrigerating, and AUX works for</p>	-110~ +110%

		<p>heating.</p> <p>In a bidirectional system, the heating and refrigerating ability are generally different.</p> <p><math>OPL = -(\text{power when AUX output is maximum} / \text{power when OUP output is maximum}) \times 100\%</math>.</p> <p>For example, for a heating/refrigerating air condition, its maximum power of refrigerating is 4000W, and maximum power of heating is 5000W, and AUX works for refrigerating, then</p> <p><math>OPL = -(4000/5000) \times 100\% = -80\%</math></p> <p>The range of AUX output can't be freely defined by user. If the internal calculation requires maximum output of AUX (AUX output=OPL), then in 4~20mA output, the AUX output is 20mA, and user can't limit the maximum AUX output to 10mA.</p>	
<b>OPH</b>	Output upper limit	OPL limits the maximum of OUP (main output). OPH should be greater than OPL.	0~110%
<b>ALP</b>	Alarm output allocation	<p>From right side to left side, the first, second, third and fourth digit of ALP individually indicate the alarm output terminal of HIAL, LoAL, HdAL, and LdAL. 0 shows no output. 1 and 2 are spare for future use. 3,4,5 and 6 respectively indicate alarms outputted to AL1, AL2, AU1 or AU2.</p> <p>For example,</p> $ALP = \frac{5}{LoAL} \quad \frac{5}{HdAL} \quad \frac{0}{LoAL} \quad \frac{3}{HIAL}$	0~5555

		<p>It shows that HIAL is sent to AL1, LoAL has no output, HdAL and LdAL are sent to AU1.</p> <p>Note 1: When AUX is used as auxiliary output in bidirectional (heating/refrigerating) control, alarm to AU1 and Au2 won't work.</p> <p>Note 2: Installing L5 dual relay output module in ALM or AUX can implement AL2 or AU2 alarm.</p>	
<b>CF</b>	System function selection	<p>CF is used to select some system function. The value of CF is calculated as below:  <b>CF=A×1+B×2+C×4+D×8+E×16+F×32+G×64+H×128</b>  <b>A=0</b>, reverse action control mode. When this mode is selected, an increase in PV results in a decrease in the control output. Ex, heating control.  <b>A=1</b>, direct action control mode. When this mode is selected, an increase in PV results in an increase in the control output. Ex, cooling control.  <b>B=0</b>, without the function of alarm suppressing at power on or setpoint changing.  <b>B=1</b>, having the function of alarm suppressing at power on or setpoint changing. Refers to the description in the latter text.  <b>For AI-708P/808P,</b>  <b>C=0</b>, When the instrument work as a program generator, the upper window displays the program step; <b>C=1</b>, it displays PV ( measurement</p>	0~255

value).

**D=0**, The unit of program time is minute; **D=1**, the unit is second.

**For AI-708/808,**

**C=0**, The setpoint is restricted between LoAL and HIAL; **C=1**, no restriction on the setpoint.

**D=0**, no remote setpoint input function; **D=1, (for AI-808 only)**, allow remote setpoint input.

**E=0**, disable the function of sectional power restriction

**E=1**, enable the function of sectional power restriction

**F only works on A2/C3 dimension instrument which has a light bar.**

**F=0**, light bar indicates output value

**F=1**, light bar indicates measurement value

**G=0**, When alarm is triggered, the alarm symbol is alternatively displayed on the lower window. It is helpful for user to know the cause of the alarm.

**G=1**, disable alarm symbol display.

**H=0**, unilateral hysteresis is applied; **H=1**, bilateral hysteresis is applied (in order to compatible with old version V6.X).

**For example:** if it is expected that the instrument service as reverse action control; has the function of alarm suppressing at power on; no restriction on the range of setpoint; no sectional power restriction; no light bar; alternatively display alarm symbol when alarming, then we get



		A=0, B=1, C=1, D=0, E=0, F=0, G=0. And so parameter “CF” should be set as follows: <b>CF=0×1 + 1×2 + 1×4 + 0×8 + 0×16 + 0×32 + 0×64 = 6</b>	
<b>Addr</b>	communication address	In the same communication line, different instrument should be set to different address.	0~100
<b>bAud</b>	Communication baud rate	The range of communication baud rate is 1200~19200bit/s.  If linear current output module X3 or X5 is installed in COMM socket, PV can be retransmitted to 0~20mA or 4~20mA signal, and outputted from COMM port. At this situation, parameter “Addr” and “Baud” is used to define the scale of linear current for the corresponding retransmission output. “Addr” is used to define output low limit and “bAud” is used to define output high limit. The unit is 0.1mA. For example, a 4~20mA retransmission output can be defined by Addr=40,bAud=200.	0~19200
<b>dL</b>	PV input filter	The value of dL will determine the ability of filtering noise. There is one intermediate-value filter system and one second order integral digital filter system in AI series instrument. Intermediate value filter takes intermediate value among three continuous values, while integral filter has the same effect as resistance-capacity integral filter. If measurement input fluctuates due to noise, then digital filter can be	0~40

		<p>used to smooth the input. Parameter “dL” may be configured in the range of 0 to 20, among which, 0 means no filter, 1 means intermediate-value filter and 2~20 means that intermediate-value filter and integral filter can be selected simultaneously.</p> <p>When a large value is set, the measurement input is stabilized but the response speed is slow. Generally, it can be set to 1 to 3.</p> <p>If great interference exists, then you can increase parameter “dF” gradually to make momentary fluctuation of measured value less than 2 to 5.</p> <p>When the instrument is being metrological verified, “dF” s can be set to 0 or 1 to shorten the response time.</p>	
<b>run</b>	System running mode	<p><b>1. For AI-808 type, parameter RUN is used to define Automatic/manual working status as below.</b></p> <p><b>Run=0</b>, Manual control state</p> <p><b>Run=1</b>, Automatic control state</p> <p><b>Run=2</b>, Automatic control state, in this state manual operation is prohibited. When the manual function is not required, it can avoid entering manual state due to operator’s false operating.</p> <p>As auto/man transfer can be carried out directly from the keypad, it is not needed to adjust parameter RUN to perform auto/man transfer.</p>	

However, when a computer is used to control the instrument via RS232C or RS485 communication interface, adjusting parameter RUN from computer can carry out the transfer of auto/man status.

**2. For AI-708P/808P type, parameter RUN is used to define the event-handling mode when program is running.**

Abrupt actions affecting control execution of program are called event, as the outcomes of events are always probably unpredicted, the aim of event handling is to turn those unpredicted things into predicted results.

**Run=A×1+D×8+F×32**

Among which: A is used to select 5 kinds of power-cut event handling modes; D is used to select 4 kinds of run /modify event-handling modes; F is used to select 3 auto/manual control states for AI-808P.

**There are five handling functions for AI-708P/808P series instrument when power resume after power cut.**

**A=0**, start to run the program from step 1 unless the instrument was in “stop” state before power cut.

**A=1**, if these is deviation alarm after power resume, then stop the program, otherwise, continue to run the program from the original break point.

		<p><b>A=2</b>, continue to run the program from the original break point..</p> <p><b>A=3</b>, stop the program.</p> <p><b>A=4</b>, go into HOLD state after power on. If it is in StoP state before power cut, then keep in StoP State after power on.</p> <p><b>Run/modify event handling</b></p> <p><b>D=0</b>, neither PV startup nor PV preparation function. Program is executed as planned. This mode guarantees constant running time of the program, but it can't guarantee the integrity of the whole curve.</p> <p><b>D=1</b>, With the function of PV startup and without the function of preparation.</p> <p><b>D=2</b> With the function of preparation and without the function of measurement value startup.</p> <p><b>D=3</b> With the function of measurement value startup and preparation.</p> <p>For details about PV startup function and PV preparation function, see program instruction later chapter.</p> <p><b>F is used to select the control mode of Auto and Manual (for AI-808P only)</b></p> <p><b>F=0</b> Auto control mode</p> <p><b>F=1</b> Manual control mode</p> <p><b>F=2</b> Works on Auto mode and is not able to be switch to Manual mode from front panel.</p>	
--	--	--	--

		<p><b>For example:</b> if it is needed that the instrument continue program running from the original break point after power on, have the function of measurement value start up and preparation, and the instrument works on Auto mode, then you can set as below: A=2,B=1, and so we get parameter:  <b>Run=2×1+3×8+0×32=26</b></p>	
<b>Loc</b>	Parameter lock	<p>If parameter Loc is set to other values than 808, then only field parameters in the range of 0 to 8 and parameter Loc itself can be set. When parameter Loc is set to 808, user can set all parameters. Parameter Loc provides several operation privileges. When user has completed setting some important parameters such as input and output, parameter Loc can be set to other values than 808 in order to avoid field operators' accidental modification of some important operation parameters. See the following:</p> <ol style="list-style-type: none"> <li><b>for AI-708/808 series instrument</b>  <b>Loc=0</b>, allowed to modify field parameters and setpoint.  <b>Loc=1</b>, allowed to view field parameters, and to set setpoint. But the modification of field parameters (except parameter Loc itself) is not allowed.  <b>Loc=2</b>, allowed to display and view field parameters, but the modification of field parameters and setpoint (except parameter Loc itself) is not allowed.</li> </ol>	0~9999

		<p><b>Loc=808</b>, configuration of all parameters and setpoint is allowed.</p> <p><b>2. For AI-808P series instrument</b></p> <p><b>Loc=0</b>, allowed to modify field parameters, program value (time and temperature value) and program segment number StEP.</p> <p><b>Loc=1</b>, allowed to modify field parameters and StEP value, but the modification of program is not allowed.</p> <p><b>Loc=2</b>, allowed to modify field parameters, but not allowed to modify StEP value and program.</p> <p><b>Loc=3</b>, only allowed to modify parameter Loc itself, all other parameters, program and StEP value can not be modified.</p> <p><b>Loc=808</b>, allowed to set all parameters, program and StEP value.</p> <p><b>Note:</b> that 808 is the password of all AI series instrument. In application the instrument should be set to other values to protect from modifications of parameters. Meanwhile the management of production should be enforced to avoid arbitrary operation.</p> <p>If Loc is set to other values than the above mentioned, the result may be one of those above mentioned, and most of them are the same as when loc=1 is set.</p> <p>If you Set Loc to be 808 during field parameter setting, parameter Loc will automatically turned to be 0 when you finished setting field parameter. If you set Loc to be 808 after the parameters are unlocked, parameter Loc will be saved as 808 permanently.</p>	
--	--	---	--

<p><b>EP1~ EP8</b></p>	<p>Field parameter definition</p>	<p>1 to 8 field parameters can be defined by parameters EP1to EP8. If the number of the field parameters is less than 8, the first idle EP parameter should be set to “nonE”. The initial values of EPs and Loc are EP1=HIAL, EP2=LoAL, EP3=HdAL, EP4=LdAL, EP5=nonE, EP6=nonE, EP7=nonE, EP8=nonE and Loc=0. You can redefine field parameters and Loc to change operation style. For example, you can execute auto tuning from field parameter instead of by pressing  in basic display status, and only take HIAL and HdAL as field parameter. The EP paramters and Loc should be set as below: EP1=HIAL, EP2=dHAL, EP3=At, EP4=nonE, Loc=1</p>	<p>nonE and all parameter codes</p>
----------------------------	-----------------------------------	---	-------------------------------------

### 3.3 Additional Remarks of Special Functions

#### 3.3.1 Alarm blocking at the beginning of power on

Some unnecessary alarms often occur at the beginning of power on or when the setpoint is modified. For example, in a heating system, at the beginning of powers on, its temperature is much lower than the setpoint. If low limit and deviation low limit are set and the alarm condition are satisfied, the instrument should alarm, but there is no problem in the system. Contrarily, in an refrigerating system, the unnecessary high limit or deviation high limit alarm may occur at the beginning of power on. Therefore, AI instruments offer the function of alarm blocking at the

beginning of power on (CF.B=1). Alarm blocking function is correlative to direct/reverse action control. In a reverse action control system (CF.A=0), the corresponding absolute and deviation low limit alarms are blocked until the alarm condition first clears. If the alarm condition is satisfied again, the alarm will work. Similarly, in a direct action control system, the absolute and deviation high limit alarms are blocked.

### **3.3.2 Setpoints switch**

If an I2 module is installed in MIO socket, a switch or button can be connected to terminal number 14 and 16. For AI-708/808, the switch can switch between two different setpoints SP1 and SP2. For AI-708P/808P, pressing the button for about 0.3~1 second can run or hold the program, and pressing the button and holding for more than 4 seconds will stop the program.

### **3.3.3 Sectional power restriction**

With regards to some high temperature electric resistance furnace whose heating materials is silicon-molybdenum bar or tungsten filament, the resistance of there heater in cold condition is much lower than that in hot condition, so the furnace current will exceed its rated current greatly in cold condition. If the instrument works in automatic control mode, full power output in cold condition will lead to power switch trip and shorten the heating materials service life to a large extent.



The function of sectional power restriction will be executed if CF.E=1. Then the instrument output lower limit will be fixed on 0, while oPL is the output upper limit when the temperature is lower than the value of lower limit alarm. If the temperature is higher than the lower limit alarm value, oPH is the upper limit of output. In this way, the instrument can work with 2 optional power according to the measurement in order to restrict the oversized current in cold condition. Lower limit alarm function will be canceled when sectional power restriction function is active.

For example: If it is needed that output power should be restricted to 20% when the furnace temperature is lower than 600°C and 100% when the temperature is higher than 600°C. Parameters is as follows:

LoAL=600, oPL=20, oPH=100, CF.E=1 (see parameter CF for details).

### **3.3.4 User defined non-linear table**

User can define a non-linear table. This table can provide special input specification (Sn should be set to 10), or output power restriction on different temperature sections.

#### **3.3.4.1 Enter non-linear input specification define state**

(If Loc=808, first set Loc=0 and exit parameter setting state.) Set parameter Loc = 3698 and then press  can enter non-linear table setting.

#### **3.3.4.2 Non-linear table setting:**

**A00=0**, the table is for non-linear input measurement

**A00=1**, the table is for sectional output power restriction

**A01 indicates input type:  $A01 = Ax1 + Ex16 + Gx64$**

**A01.A** indicates input range:

A01.A=0, 20mV(0~80ohm);

A01.A=1, 60mV(0~240ohm);

A01.A=2, 100mV(0~400ohm);

A01.A=3, 1V;

A01.A=4, 5V

**A01.E=0**, the value generated from the table should be scaled by parameter dIL and dIH again,  
and then displayed

**A01.E=1**, the displayed PV is the value generated from the table.

**A01.G** indicates the input signal type.

**A01.G=0**, thermocouple

**A01.G=1**, RTD

**A01.G=3**, linear voltage/current

**A01.G=0**, linear resistance

For example, for a non-temperature, 1~5V voltage signal,  $A01=4 \times 1 + 0 \times 8 + 2 \times 64 = 132$

**A02** represents the low limit of the input signal.  $A03 = \text{low limit} \times 20000 / \text{range}$ . For example, for 1~5V voltage input,  $A02 = 1 \times 20000 / 5 = 4000$ .

**A03** represents the length of the input signal range.  $A03 = \text{length} \times 20000 / \text{range}$ . For example, for 1~5V signal, the length is  $5 - 1 = 4V$ , then  $A03 = 4 \times 20000 / 5 = 16000$

**A04** shows the interval between points.  $A04 = A03 / \text{the number of segments}$ . For example, in above example, if there is only 1 segment, then  $A04 = A03 = 16000$ .

**d00** shows the start point of the non-linear table. It is the output value corresponding to A02. For example, in the above sample, it can be set to 0.

**d01** = the output value corresponding to  $A02 + A04$ .

**dnn (nn=02~60)**, **dnn** = the output value corresponding to  $A02 + A04 \times nn$

Through the above table, even complex curve such as extraction, log, or exponent can be defined.

**Sectional output power restriction for high temperature stove (A00=1, this special function should be requested when ordering).**

For example, a restriction for a MoSi<sub>2</sub> heating element can be set as below:

A01=1; A02=100.0; A03=1500; A04=750.0; d00=120.0; d01=1100, d02=2000

It means: when the temperature is lower than 100°C, the maximum output power is 6% (2000 means 100%, and 120.0/2000=6%); when the temperature is between 100~850°C, the maximum output is 55%; when the temperature is higher than 1600°C, the maximum output is 100%.

#### **4. Further description for the operation of AI-708P/808P series instrument**

AI-708P/808P program type temperature controller is used in the application where the setpoint should be changed automatically with the time. It provides 50 segment program control which can be set in any slope and the function of jump, run, hold and stop can also be set in the program.

##### **4.1 Main function**

- 50 segments program control which can be set in any slope.
- High flexibility in program and operation. It has programmable/maneuverable commands such as jump (the object step no. should be less than 30). Run, Hold and stoP. It is allowed to modify the program at anytime no matter if the program is running or not.
- 2 event output function. Able to control the interlock of other equipment via alarm output, and further improve the automation.
- Measurement startup function and preparation function can make program run more efficiently.

- 4 power-cut/power-resume event handling modes selectable. This can prevent the program control from being affected by unexpected power-cut.

## 4.2 Concepts and functions

**Program StEP:** The NO. Of the program StEP can be defined from 1 to 50, and the current StEP is the program StEP being executing.

**StEP time:** the total running time of the program StEP. The unit is minute and the available value range from 1 to 9999.

**Running time:** time that the current StEP has run. As the running time reaches the StEP time, the program will jump to the next StEP automatically.

**Jump:** the program can jump to any other steps in the range of 1 to 30 automatically as you programmed in the program StEP, and realize cycle control. If the StEP No. Is modified, the program also will jump.

**Run/Hold:** when program is in the running status, timer works, and setpoint value changes according to the preset curve. When Program is in the holding status, timer stops, and setpoint remains.

The holding operation can be programmed into the program StEP. When the program meets with the StEP, the StEP time of that is set to zero, or when a jumping StEP jumps to another jumping StEP, the program will get in Hold status. Hold/Run operation can also be performed manually at any time.

**Stop:** when the stoP operation is activated, the program will stop, the running time will be clear and timer will stop, event output switch is reset and the output control is stopped. If run operation is activated when instrument is in the stoP status, the program will start-up and run from the StEP NO. set.

The stoP function can be programmed into the program StEP. The running StEP NO. Can be set at the same time. The stoP operation can also be performed manually at any time. (After stoP operation is done, the StEP NO. Will be set to 1, but user can modify it again).

**Power cut /resume event handling:** There are four event handling method selectable for power resume after power cut.

**Event output:** Event output can be programmed in the instrument, it can trigger two alarm output (AL1 and AL2) to make external equipment operate with interlock.

**PV startup and PV preparation function:** At the beginning of starting a program, resuming a program after power cut or continuing to run a program after it is just modified, the PV (process value) are often quite different from the setpoint. PV startup function and PV preparation function can make PV and setpoint consistent, and avoid unexpected result.

When PV startup function is enable, the instrument will adjust the running time automatically to make the expected setpoint is the same as the current PV.

For example, the program is set that the temperature will be raised from 25°C to 625°C in 600 minutes. But the current PV is 100°C, then the instrument will automatically adjust the running time to 75 minutes, and then run the program.

At the above situation, when PV preparation function is enable, the alarm will be blocked, and PV will be adjusted to approach SV until the deviation alarm condition is released (PV is between SV-LdAL and SV+HdAL). Then the controller start the program. Preparation function is helpful to keep the integrity of the program, but it will prolong the program time because the start of the program is postponed.

PV startup function is prior to PV preparation function. If both function are enabled, the system apply PV startup first, if PV startup function works, PV preparation function will not be activated.

**Curve fitting:** curve fitting is adopted as a kind of control technology for AI-708P/808P series instrument. As controlled process often has lag time in system response, by the way of curve fitting the instrument will smooth the turning point of the linear heating-up, cooling-down and constant temperature curves automatically. The degree of the smooth is relevant with the system's lag time, the longer of the lag time, the deeper of the smooth degree. On the opposite the smooth function will be weaker. Generally the shorter of the process lag time (such as temperature inertia), the better of the program control on effect. By the way of the curve fitting to deal with the program curves, will avoid overshoot. Note: The characteristic of the curve fitting will force the program control to generate

fixed negative deviation during the linear heating-up and fixed positive deviation during the linear cooling-down, the deviation is direct proportional to the lag time (t) and the speed of heating-up (cooling-down). This phenomenon is normal.

**External input event:** The external input event will be activated by the on/off of the external mechanical switch connected to instrument. It can force the instrument to run, Hold and StoP. It can also make the program run automatically or many instruments start up at the same time under the program control. The instrument interface OUT2, COMM and AL2 can act as external event input interface, wiring diagram is as follows. If you set F=0 while setting parameter ALP, module I2 which is installed on OUT2 will act as an external event input interface. Module I which is installed on AL2 or COMM can also act as external event input interface (when C=1 in the parameter CF). A none selfhold switch is used to operate the external control interface. As regards to the interface installed on COMM or AL2, 3-24VDC impulse voltage (internal photocoupler should absorb 3-5mA current) can also used for control. Press the switch and then release (about 0.3-1 second), the instrument will execute the operation of (run/Hold), press the switch and hold for at lest 4 seconds, the instrument will execute the operation of stoP.



19  
connecting  
terminal  
20  
OUT2

18  
19  
20  
COMM

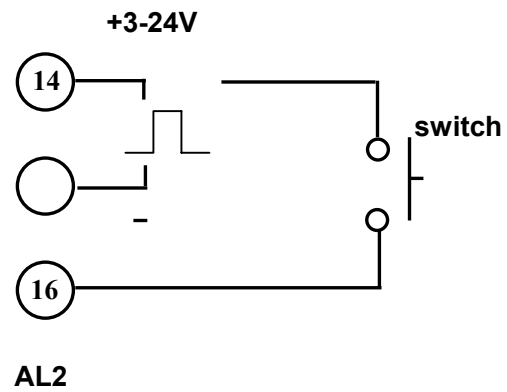

### 4.3 Programming and operation

Programming of AI series instrument has uniform format of temperature-time-temperature, which means that temperature set for current StEP will change to temperature set for next StEP after the time set for the current StEP. The unit of temperature set is °C and the unit of time set is minute. The following example includes 6 steps, which is linear temperature heating up, constant temperature, linear temperature cooling down, jump cycling, ready, Hold and event output.

**StEP1: C01=100 , t01=30** Start linear temperature heating up from 100°C, and the time needed is 30 minutes.

**StEP2: C02=400 , t02=60** Raise temperature to 400°C, slope of raising curve is 10°C/minute, and the time for temperature to remain constant is 60 minutes.

**StEP3: C03=400 , t03=120** The StEP for temperature cooling down, slope of cooling curve is 2°C /minute, and the time needed is 120 minutes.

**StEP4: C04=160 , t04=-35** Temperature cool down to 160°C, then alarm 1 is triggered, and the program jump to StEP5.

**StEP5: C05=160 , t05=0** The program get in Hold state, and run operation executed by operator is needed for the program to continue running to StEP 6.

**StEP6: C06=100 , t06=-151** Alarm 1 is switch off, and jump to StEP1 to start from beginning.

In this example, it is assumed that the positive deviation alarm is set to 5°C. Because the temperature of StEP 6 is 160°C, and the temperature of StEP1 is 100°C, when program jumps from StEP 6 to StEP 1, the program will change to preparation state at first, i.e., Control the temperature until the deviation between setpoint and PV is less than positive deviation alarm value. After temperature is controlled to 105°C, the program will be started from StEP 1, and run the above steps again. The temperature control block is shown below.

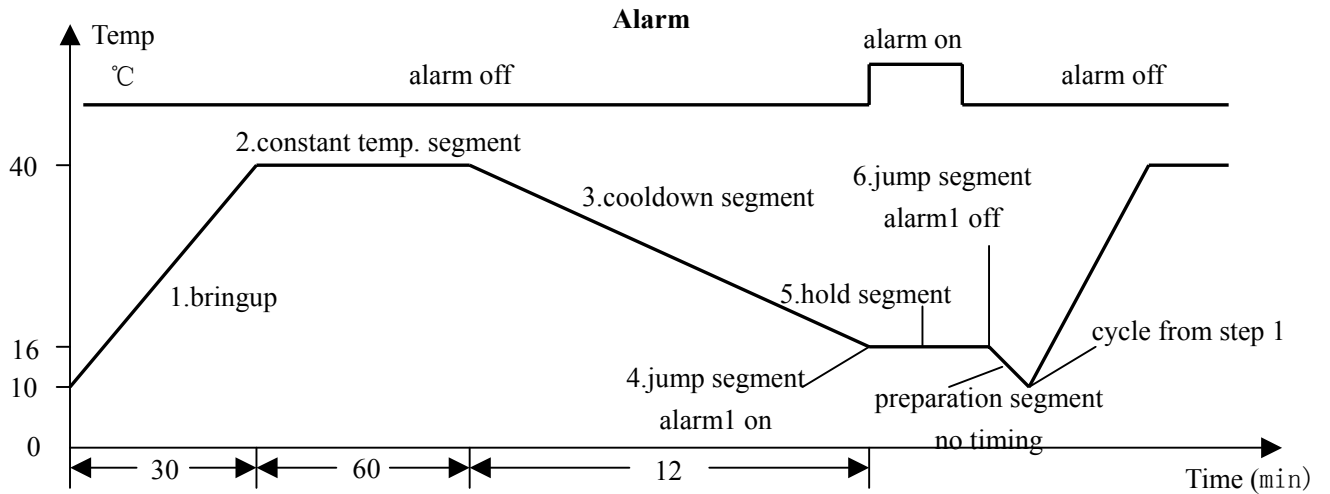

### 4.3.1 Time setup

**txx = 1—9999 (min)** setting time of No. xx StEP

**txx = 0** the program is hold on StEP xx

**txx = -1—-240** negative value of time represents an operation command such as: run, Hold, stoP, jump and even output, the signification is as follows:

**txx = - (Ax30+B)**

**B** indicates (range from 1 to 30) the StEP number that the program want to jump to

**A** defines two even output. controls the work of AL1, AL2 and automatic stop, as follows:

A=0 no effect (for jump function only)

A=1 switch on AL1

A=2 switch on AL2

A=3 switch on AL1 and AL2

A=4 Stop the instrument (B must be set to B=1)

A=5 switch off AL1

A=6 switch off AL2

A=7 switch off AL1 and AL2

**txx = -241** A pulse of 0.5 second occurs on AL1, and the program goes to next segment. The pulse will be cancelled if AL1 has been switch on (whatever by the event output or by the

alarm signal)

**Example:**

- StEP4 is defined as: jump to StEP5 and switch on AL1.  
Time setup is:  $t\ 04 = -(1 \times 30 + 5) = -35$
- StEP6 is defined as: jump to StEP1 and switch off AL1.  
Time setup is:  $t\ 06 = -(5 \times 30 + 1) = -151$
- Program stop at StEP8  
Time setup is:  $t\ 08 = -(4 \times 30 + 1) = -121$

**Note:** The program will be held if it jump from a control segment to another control segment (an Hold action will be inserted between two control sections), external run/Hold operation is needed to release the Hold status. It is not allowed that the jump section jump to itself (for example:  $t\ 06 = -6$ ), otherwise, the Hold status can not be released.

### 4.3.2 Setpoint setup

**Cxx** = -1999~+9999 (units or °C)

### 4.3.3 Program arrangement of multi-curve operation

AI-808P has the advanced function of flexible program arrangement. Normally, when the program stops, the StEP will be automatically set to 1. Thus if StEP is not change to other value, a program will start from step 1. If multiple curves are defined, the control can jump to different curve by setting step 1 as jump segment.

**For example:** There are three curves with the length of 8 steps represent three groups of process parameter, they are separately arranged on StEP2-StEP9, StEP10-StEP17, StEP18-StEP25. Settings are as follows:

- t01=-2 Execute the program of curve 1 (StEP2-StEP9)
- t01=-10 Execute the program of curve 2 (StEP10-StEP17)
- t01=-18 Execute the program of curve 3 (StEP18-StEP25)

**Note:** t01 setup can be omitted, if you choose the curves by setting the value of StEP before the program startup.