

BW.BWD.(120-650) 型 (单级) 外形及安装尺寸

Model BW.BWD.(120-650)(Single reduction) Contour And Installation Dimensions

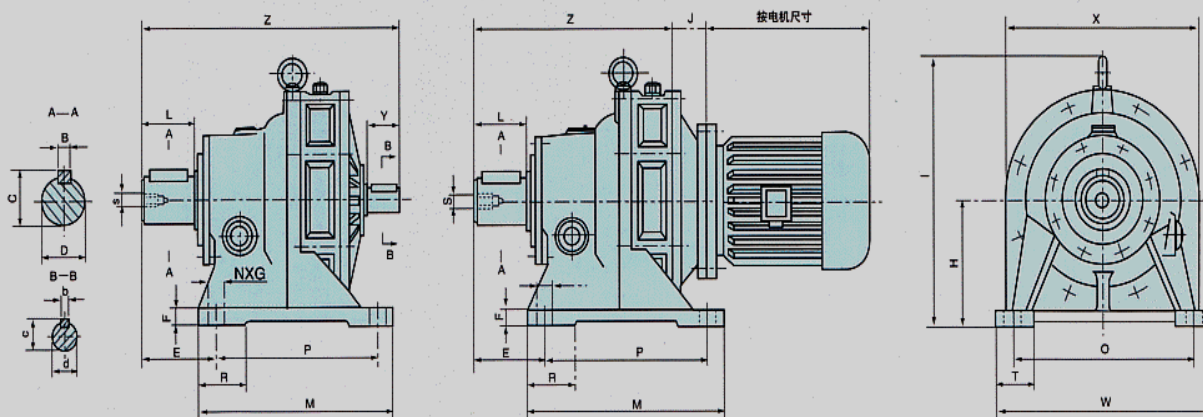

机号 SIZE	外形尺寸 Contour Dimensions				安装尺寸 Installation Dimensions										轴端尺寸 Size of shaft End							重量 Weight(kg)				
	M	W	Z		I	X	H	E	F	P	Q	S	T	N	G	B	C	D	L	b	c	d	Y	BW	BWD (约)	
BW.BWD 120-650																										
B 120	120	185	215	165	190	168	100	94	15	90	150	M8	35	4	11	8	33	30	36	5	17	15	22	15		
B 150	160	250	262	194	250	200	120	121	15	120	210	M10	50	4	13	10	38	35	56	6	20.5	18	35	22		
B 180	230	290	320	246	296	240	140	124	20	180	240	M10	60	4	15	14	48.5	45	71	6	24.5	22	40	40		
B 220	280	330	391	295	355	300	160	165	20	220	290	M12	75	4	17	16	59	55	82	8	33	30	55	73		
B 270	380	400	478	369	430	340	200	154	25	320	340	M12	75	4	22	20	74.5	70	101	10	38	35	63	120		
B330	440	470	573	437	513	400	240	159	32	380	420	M16	70	4	22	25	95	90	121	14	48.5	45	81	185		
B 390	520	560	666	526	605	500	280	188	35	440	500	M20	90	4	26	28	106	100	138	14	53.5	50	80	380		
B 450	600	690	775	578	684	570	325	230	45	500	630	M24	105	6	26	28	116	110	150	16	59	55	90	580		
B 550	810	880	1065	814	880	740	420	324	50	660	800	M30	160	6	32	32	137	130	202	20	74.5	70	120	1200		
B 650	1040	1160	1462	1151	1160	1000	540	485	60	840	1050	M42	200	6	45	45	190	180	330	25	95	90	150	2500		

BW 重量 + 电动机重量