

# EMC TEST REPORT

For

**PDA(SHENZHEN)TECHNOLOGY CO., LTD**

## MAGNETIC LEVITATE FLOATING DISPLAY

Model No. : PA-0702,PA-0703,PA-0704,PA-0705,PA-0706,PA-0707,PA-0708,PA-0709,PA-0710,PA-0711,PA-0712,PA-0713,PA-0714,PA-0715,PA-0716,PA-0717,PA-0718,PA-0719,PA-0720,PA-0915,PA-0903,PA-0907,PA-0922,PA-0920,PA-0920-8,PA-ball C,PA-8871,PA-034,PA-038,PA-039,PA-0240,PA-8871,PA-0373-UFO,PA-0745-P,PA-8805-C,PA-0247,PA-8874-E,PA-0372,PA-0230,PA-FC,PD360,PA-0403,PA-0402,PD361,PA-9936,PA-0301,PA-0303,PA-0304,PA-0321,PA-0326,PA-0327,PA-0338,PA-1005,PA-0107,PA-0331,PA-0651,PA-0338,PA-0319,PA-1000,PA-1004,PA-1008

Prepared for : PDA(SHENZHEN)TECHNOLOGY CO., LTD  
14 floor ,Yaleju ,hangcheng street, xixiang ,Bao' an District ,shenzhen ,china

Prepared By : Shenzhen ECT Testing Technology Co., Ltd.  
Room 1106,Era Innovation Center, Xixiang Gushu Second Road,Baoan District,Shenzhen City, China

Tel : (86) 755-23062275  
Fax : (86) 755-26609102

Report No. : ECT2018E042473-Y1

Date of Test : Apr.24-May .04 .2018

Date of Rep. : May .04 .2018

## TABLE OF CONTENT

Description	Page
Test Report Declaration	
<b>1. GENERAL INFORMATION .....</b>	<b>4</b>
1.1. Description of Device (EUT) .....	4
1.2. Test Facility.....	5
1.3. Test Facility.....	5
1.4. Uncertainty.....	5
1.5. Description of Test System.....	5
<b>2. TEST INSTRUMENT USED .....</b>	<b>6</b>
<b>3. RADIATED EMISSION TEST .....</b>	<b>8</b>
3.1. Block Diagram of Test Setup .....	8
3.2. Test Standard .....	8
3.3. Radiated Emission Limit .....	9
3.4. EUT Configuration on Test .....	9
3.5. Operating Condition of EUT.....	9
3.6. Test Procedure .....	10
3.7. Radiated Emission Test Result.....	10
<b>4. ELECTROSTATIC DISCHARGE TEST .....</b>	<b>11</b>
4.1. Block Diagram of Test Setup .....	11
4.2. Test Standard .....	11
4.3. Severity Levels and Performance Criterion .....	11
4.4. EUT Configuration on Test .....	13
4.5. Operating Condition of EUT.....	13
4.6. Test Procedure .....	13
4.7. Test Results.....	13
<b>5. RF FIELD STRENGTH SUSCEPTIBILITY TEST .....</b>	<b>15</b>
5.1. Block Diagram of Test Setup .....	15
5.2. Test Standard .....	15
5.3. Severity Levels and Performance Criterion .....	15
5.4. EUT Configuration on Test .....	16
5.5. Operating Condition of EUT.....	16
5.6. Test Procedure .....	16
5.7. Test Results.....	16
<b>6. MAGNETIC FIELD IMMUNITY TEST .....</b>	<b>17</b>
6.1. Block Diagram of Test Setup .....	17
6.2. Test Standard .....	17
6.3. Severity Levels and Performance Criterion .....	17
6.4. EUT Configuration on Test .....	18
6.5. Operating Condition of EUT.....	18
6.6. Test Procedure .....	18
6.7. Test Results.....	18

APPENDIX I ----- Radiated Emission Test Data

APPENDIX II ----- Photographs of the EUT

## TEST REPORT DECLARATION

Applicant : PDA(SHENZHEN)TECHNOLOGY CO., LTD  
Manufacturer : PDA(SHENZHEN)TECHNOLOGY CO., LTD  
EUT Description : MAGNETIC LEVITATE FLOATING DISPLAY

(A) Model No. : PA-0702  
(B) Serial No. : N.A  
(C) Power Supply : DC

### Test Procedure Used:

**EMI:** EN 55032:2015



**EMS:** EN 55024:2010/A1:2015

The device described above has been tested by **Shenzhen ECT Testing Technology Co., Ltd** to determine the maximum emission levels emanating from the device, the severe levels that the device can endure and EUT'S performance criterion. The test results are contained in this test report. Also, this report shows that the EUT technically complies with the 2014/30/EU directive and its amendment requirements.

This report applies to above tested sample only and shall not be reproduced in part without written approval of **Shenzhen ECT Testing Technology Co., Ltd**.

Date of Test: Apr.24-May .04 .2018

Prepared by:   
Project Engineer

Reviewed by:   
  
Project Manager

Approved by:   
Technical Director

## 1. GENERAL INFORMATION

### 1.1. Description of Device (EUT)

Description : MAGNETIC LEVITATE FLOATING DISPLAY

Model Number : PA-0702,PA-0703,PA-0704,PA-0705,PA-0706,PA-0707, PA-0708,PA-0709,PA-0710,PA-0711,PA-0712,PA-0713, PA-0714,PA-0715,PA-0716,PA-0717,PA-0718,PA-0719, PA-0720,PA-0915,PA-0903,PA-0907,PA-0922 ,PA-0920, PA-0920-8,PA-ballC,PA-8871,PA-034,PA-038,PA-039,P A-0240,PA-8871,PA-0373-UFO,PA-0745-P,PA-8805-C,P A-0247,PA-8874-E,PA-0372,PA-0230,PA-FC,PD360,PA- 0403,PA-0402,PD361,PA-9936,PA-0301,PA-0303,PA-03 04,PA-0321,PA-0326,PA-0327,PA-0338,PA-1005,PA-01 07,PA-0331,PA-0651,PA-0338,PA-0319,PA-1000,PA-10 04,PA-1008

Applicant : PDA(SHENZHEN)TECHNOLOGY CO., LTD  
Address : 14 floor ,Yaleju ,hangcheng street, xixiang ,Bao' an District ,shenzhen ,china

Manufacturer : PDA(SHENZHEN)TECHNOLOGY CO., LTD  
Address : 14 floor ,Yaleju ,hangcheng street, xixiang ,Bao' an District ,shenzhen ,china

Date of Test : Apr.24-May .04 .2018

## 1.2. Test Summary

<b>Test Items</b>	<b>Standards</b>	<b>Status</b>
Radiated emission test	EN55032:2015	Complied
Electrostatic discharge Test	EN61000-4-2: 2009	Complied
RF Field strength susceptibility Test	EN61000-4-3: 2006+A1:2008+A2:2010	Complied
Magnetic field immunity test	EN61000-4-8: 2010	Complied

## 1.3. Test Facility

Test Firm	: Shenzhen ECT Testing Technology Co., Ltd.
Address	: Room 1106,Era Innovation Center, Xixiang Gushu Second Road,Baoan District,Shenzhen City, China
Tel	: (86) 755-23062275
Fax	: (86) 755-26609102

## 1.4. Uncertainty

Radiated Emission Uncertainty =  $\pm 4.26\text{dB}$

## 1.5. Description of Test System

PC	DELL	E6420
Monitor	DELL	OG335H
Keyboard	DELL	SK-8115

## 2. TEST INSTRUMENT USED

No.	Equipment	Manufacturer	Model No.	S/N	Cal. Date	Next Cal. Date
1	ESD TESTER	HAEFELY	PESD1610	H401552	2017.11.16	2018.11.15
2	MAGNETIC FIELD TESTER	HAEFELY	MAG100	150577	2017.11.16	2018.11.15
3	5KVA AC POWER SOURCE	CALIFORNIA INSTRUMENTS	5001ix-400	55692	2017.11.16	2018.11.15
4	HARMONICS/FLICKER TEST ANALYZER	CALIFORNIA INSTRUMENTS	PACS-1	72254	2017.11.16	2018.11.15
5	50Ω COAXIAL SWITCH	ANRITSU	MP59B	6200283933	2017.11.16	2018.11.15
6	CONICAL HOUSING	ATC	N/A	N/A	N/A	N/A
7	VOLTAGE PROBE	SCHWARZBECK	TK9416	N/A	2017.11.16	2018.11.15
8	RF CURRENT PROBE	ROHDE& SCHWARZ	EZ-17	100048	2017.11.16	2018.11.15
9	BILOG ANTENNA	SCHWARZBECK	VULB9163	194	2017.11.16	2018.11.15
10	SPECTRUM ANALYZER	ANRITSU	MS2651B	N/A	2017.11.16	2018.11.15
11	PRE-AMPLIFIER	AGILENT	8447D	294A10619	2017.11.16	2018.11.15
12	RF COAXIAL CABLE(844 CHAMBER)	SCHWARZBECK	N-5m	NO.1	2017.11.16	2018.11.15
13	THERMO-HYGROMETER	OREGON SCIENTIFIC	JB913R	GZ-WS004	2017.11.16	2018.11.15
14	1# SHIELDING ROOM	CHANGZHOU ZHONGYU	843	N/A	N/A	N/A
15	2# SHIELDING ROOM	CHANGZHOU ZHONGYU	843	N/A	N/A	N/A
16	3m Semi-ANECHOIC CHAMBER	CHANGZHOU ZHONGYU	844	N/A	N/A	N/A
17	ANTENNA/TURNTABLE CONTROLLER	INNCO	CO2000	CO2000/077/7301203/L	N/A	N/A
18	101 LCR METER	YANGZHI	YD2810B	20101170	2017.11.16	2018.11.15
19	RF COAXIAL CABLE(844 CHAMBER)	NTGS8017	N-1m	NO.6	2017.11.16	2018.11.15
20	RF COAXIAL CABLE(844 CHAMBER)	NTGS8017	N-1m	NO.7	2017.11.16	2018.11.15
21	AUDIO GENERATOR	GW	GAG-809	EG835424	N/A	N/A
22	THERMO-HYGROMETER	OREGON SCIENTIFIC	JB913R	GZ-WS002	2017.11.16	2018.11.15

No.	Equipment	Manufacturer	Model No.	S/N	Cal. Date	Next Cal. Date
23	EMC PRO SYSTEM (IMMUNITY TESTER)	THERMO	PRO-BASE	0403271	2017.11.16	2018.11.15
24	CAPACITIVE CLAMP (EFT)	THERMO	PRO-CCL	0403272	2017.11.16	2018.11.15
25	COUPLER DECOUPLER FOR TELECOM LINES	THERMO	CM-TEL-CD	0403273	2017.11.16	2018.11.15
26	L.I.S.N.	ROHDE& SCHWARZ	ESH3-Z5	100305	2017.11.16	2018.11.15
27	EMI TEST RECEIVER	ROHDE& SCHWARZ	ESPI-3	100396/003	2017.11.16	2018.11.15
28	SIGNAL GENERATOR	ROHDE& SCHWARZ	SML01	101161	2017.11.16	2018.11.15
29	EMI TEST RECEIVER	ROHDE& SCHWARZ	ESPI-3	101526/003	2017.11.16	2018.11.15
30	SPECTRUM ANALYZER	AGILENT	E7405A	MY45115511	2017.11.16	2018.11.15
31	L.I.S.N.	SCHWARZBECK	NSLK8126	8126431	2017.11.16	2018.11.15
32	PULSE LIMITER (FOR ESPI3)	ROHDE& SCHWARZ	ESH3-Z2	100815	2017.11.16	2018.11.15
33	PRE-AMPLIFIER	ROHDE& SCHWARZ	CBLU1183540-0 1	3791	2017.11.16	2018.11.15
34	50Ω COAXIAL SWITCH	ANRITSU	MP59B	6200506474	2017.11.16	2018.11.15
35	BILOG ANTENNA	SCHWARZBECK	VULB9163	9163-323	2017.11.16	2018.11.15
36	HORN ANTENNA	SCHWARZBECK	BBHA9120D	9120D-655	2017.11.16	2018.11.15
37	HORN ANTENNA	SCHWARZBECK	BBHA9170	9170-359	N/A	N/A
38	LOOP ANTENNA	SCHWARZBECK	FMZB1516	1516131	2017.11.16	2018.11.15
39	ULTRA COMPACT SIMULATOR	EM TEST	UCS 500 N5	V0928104968	2017.11.16	2018.11.15
40	CAPACITIVE CLAMP	EM TEST	HFK	0509-34	2017.11.16	2018.11.15
41	Transformer	EM TEST	V4780S2	0109-44	N/A	N/A
42	Conducted Immunity Test System	FRANKONIA	CIT-10	126B1121	2017.11.16	2018.11.15
43	CDN	FRANKONIA	CDN-M2/3	A3027020	2017.11.16	2018.11.15
44	EM Injection Clamp	FCC	F-203I-23mm	091824	2017.11.16	2018.11.15
45	LISN	AFJ	LS16C	16010946249	2017.11.16	2018.11.15
46	CLICK METER	AFJ	CL55C	55040947164	2017.11.16	2018.11.15

### 3. RADIATED EMISSION TEST

#### 3.1. Block Diagram of Test Setup

##### 3.1.1. Block Diagram of EUT Test Setup

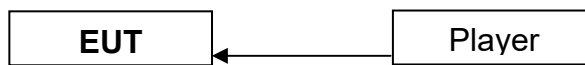

*(EUT:MAGNETIC LEVITATE FLOATING DISPLAY)*

##### 3.1.2. Anechoic Chamber Setup Diagram

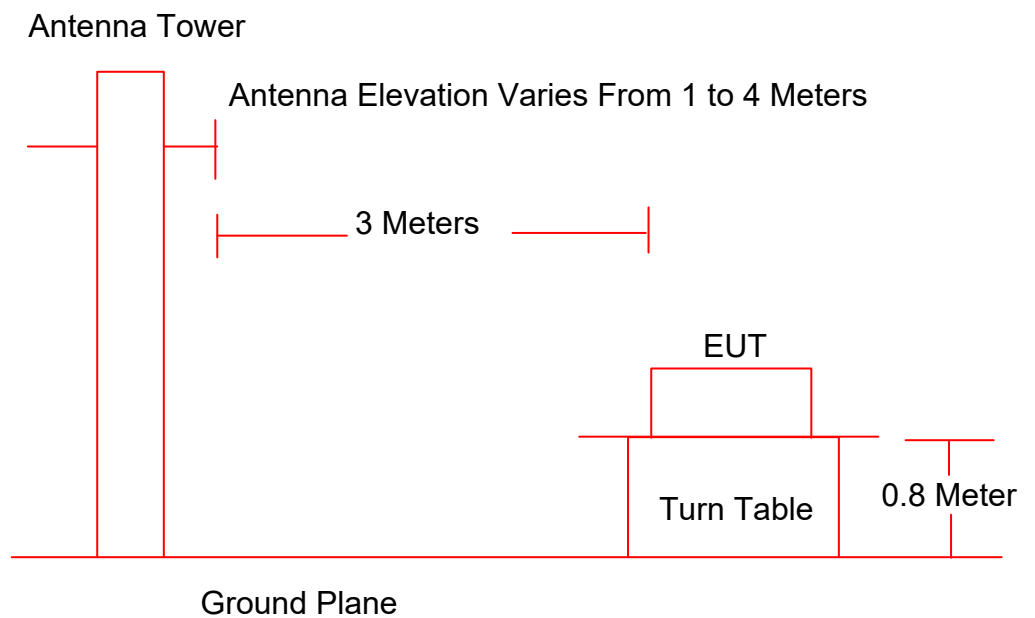

*(EUT:MAGNETIC LEVITATE FLOATING DISPLAY)*

#### 3.2. Test Standard

EN 55032:2015



### 3.3. Radiated Emission Limit

Frequency MHz	Field Strengths Limits dB( $\mu$ V)/m
30 ~ 230	40.0
230 ~ 1000	47.0

- Remark:
- (1) Emission level (dB ( $\mu$ V)/m) = 20 log Emission level ( $\mu$ V/m)
  - (2) The smaller limit shall apply at the cross point between two frequency bands.
  - (3) Distance refers to the distance in meters between the measuring instrument, antenna and the closed point of any part of the device or system.

### 3.4. EUT Configuration on Test

The EN 55032 regulations test method must be used to find the maximum emission during radiated emission test.

#### 3.4.1. MAGNETIC LEVITATE FLOATING DISPLAY (EUT)

(A) Model No. : PA-0702

(B) Serial No. : N/A

(C) Manufacturer : PDA(SHENZHEN)TECHNOLOGY CO., LTD

### 3.5. Operating Condition of EUT

3.5.1. Setup the EUT and simulators as shown in Section 3.1.

3.5.2. Turn on the power of all equipments.

3.5.3. Let the EUT work in test mode and test it.

### 3.6. Test Procedure

The EUT and its simulators are placed on a turned table that is 0.8 meter above the ground. The turned table can rotate 360 degrees to determine the position of the maximum emission level. The EUT is set 3 meters away from the receiving antenna that is mounted on the antenna tower. The antenna can move up and down between 1 meter and 4 meters to find out the maximum emission level. Broadband antenna (calibrated biconical and log periodical antenna) is used as receiving antenna. Both horizontal and vertical polarization of the antenna is set on test. In order to find the maximum emission levels, the interface cable must be manipulated according to EN55032 on radiated emission test.

The bandwidth setting on the field strength meter (R & S Test Receiver ESPI) is set at 120 KHz.

The frequency range from 30 MHz to 1000 MHz is investigated. The test data are listed in the Section 3.7 and the scanning waveform are attached within Appendix I.

### 3.7. Radiated Emission Test Result

**PASS.**

The frequency spectrum from 30 MHz to 1000 MHz is investigated.

Detailed information, please see the appendix (I) file.

## 4. ELECTROSTATIC DISCHARGE TEST

### 4.1. Block Diagram of Test Setup

#### 4.1.1. Block Diagram of EUT Test Setup

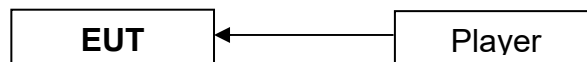

*(EUT:MAGNETIC LEVITATE FLOATING DISPLAY)*

#### 4.1.2.ESD Test Setup

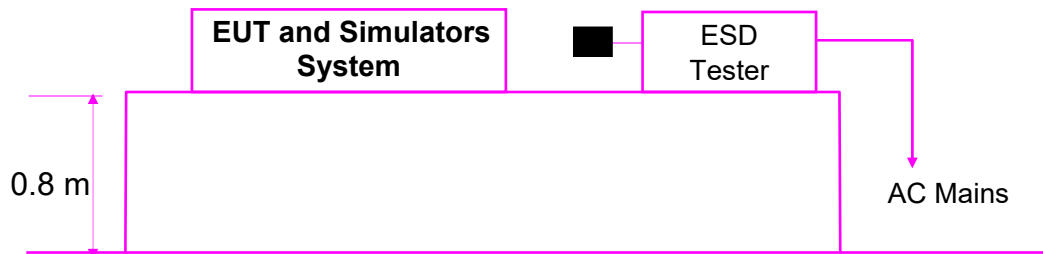

Remark: ■ is Discharge Electrode

*(EUT:MAGNETIC LEVITATE FLOATING DISPLAY)*

### 4.2. Test Standard

EN 55024:2010/A1:2015 (EN61000-4-2: 2009)

### 4.3. Severity Levels and Performance Criterion

Severity Level 3 for Air Discharge at 8KV

Severity Level 2 for Contact Discharge at 4KV

Severity Level:

Level	Test Voltage Contact Discharge (KV)	Test Voltage Air Discharge (KV)
1.	2	2
2.	4	4
3.	6	8
4.	8	15
X.	Special	Special

Performance criterion: **B**

#### 4.4. EUT Configuration on Test

The configuration of EUT is listed in Section 3.4.

#### 4.5. Operating Condition of EUT

4.5.1. Setup the EUT as shown in Section 4.1.

4.5.2. Turning on the power of all equipments .

4.5.3. Let the EUT work in test mode and test it.

#### 4.6. Test Procedure

##### 4.6.1. Air Discharge:

This test is done on a non-conductive surface. The round discharge tip of the discharge electrode shall be approached as fast as possible to touch the EUT. After each discharge, the discharge electrode shall be removed from the EUT. The generator is then re-triggered for a new single discharge and repeated 10 times for each pre-selected test point. This procedure shall be repeated until all the air discharge completed.

##### 4.6.2. Contact Discharge:

All the procedure shall be same as Section 4.6.1 except that the tip of the discharge electrode shall touch the EUT before the discharge switch is operated.

##### **Indirect discharge for horizontal coupling plane**

At least 20 single discharges shall be applied to the horizontal coupling plane, at points on each side of the EUT. The discharge electrode position is vertically at a distance of 0.1m from the EUT and with the discharge electrode touching the coupling plane.

##### **Indirect discharge for vertical coupling plane**

At least 20 single discharges shall be applied to the center of one vertical edge of the coupling plane. The coupling plane, of dimensions 0.5m X 0.5m, is placed parallel to, and positioned at a distance of 0.1m from the EUT. Discharges shall be applied to the coupling plane, with this plane in sufficient different positions that the four faces of the EUT are completely illuminated.

#### 4.7. Test Results

**PASS.**

Detailed information, Please refer to the following page.

## Electrostatic Discharge Test Results

EUT	: MAGNETIC LEVITATE FLOATING DISPLAY	Temperature	: 22°C
M/N	: PA-0702	Humidity	: 55%
Power Supply	: DC	Test Mode	: ON
<p>Air Discharge: ±8KV      For each point positive 10 times and negative 10 times discharge.</p> <p>Contact Discharge: ±4KV</p>			
Location	Kind A-Air Discharge C-Contact Discharge	Result	
Slot	A	PASS	
HCP	C	PASS	
VCP	C	PASS	
<p>Remark: Discharge should be considered on Contact and Air and Horizontal Coupling Plane (HCP) and Vertical Coupling Plane (VCP).</p>		<p>Test Equipment: See Clause 2.</p>	

## 5. RF FIELD STRENGTH SUSCEPTIBILITY TEST

### 5.1. Block Diagram of Test Setup

#### 5.1.1. Block Diagram of EUT Test Setup

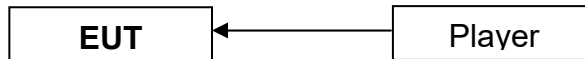

*(EUT:MAGNETIC LEVITATE FLOATING DISPLAY)*

#### 5.1.2. R/S Test Setup

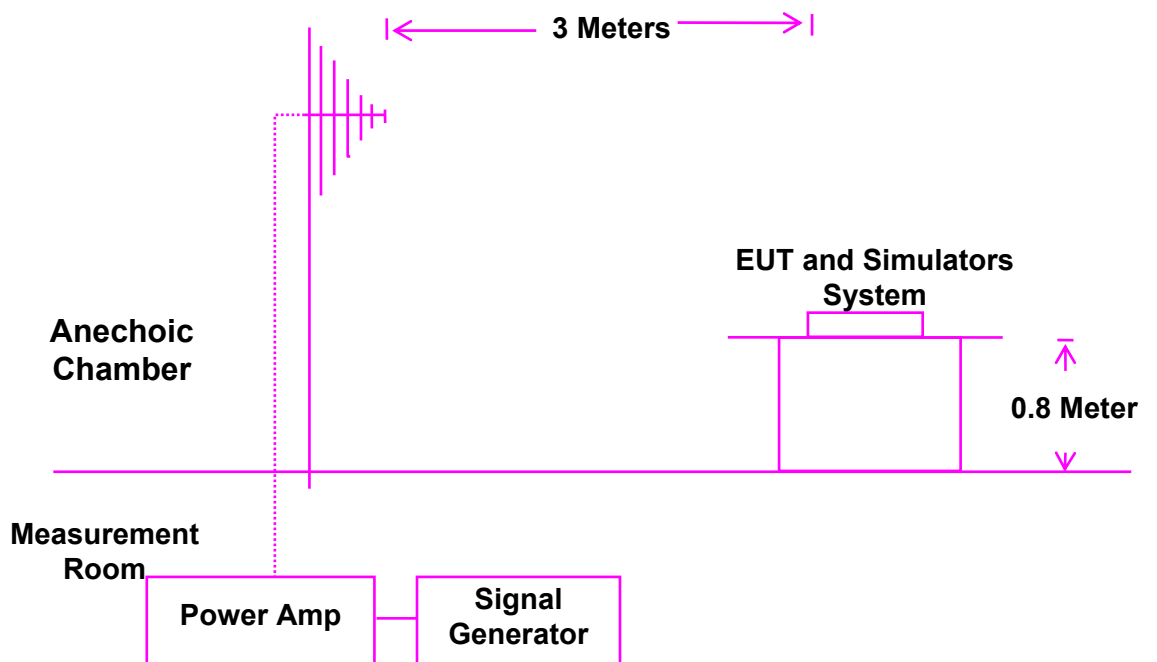

*(EUT:MAGNETIC LEVITATE FLOATING DISPLAY)*

### 5.2. Test Standard

EN 55024:2010/A1:2015 (EN61000-4-3: 2006+A1:2008+A2:2010)

### 5.3. Severity Levels and Performance Criterion

Severity Level 2 at 3V / m, Severity Level:

Level	Field Strength V/m
1.	1
2.	<b>3</b>
3.	10
X.	Special

Performance criterion: **A**

### 5.4. EUT Configuration on Test

The configuration of EUT is listed in Section 3.4.

### 5.5. Operating Condition of EUT

- 5.5.1. Setup the EUT as shown in Section 5.1.
- 5.5.2. Turn on the power of all equipments.
- 5.5.3. Let the EUT work in test mode and test it.

### 5.6. Test Procedure

5.6.1. The EUT and its simulators are placed on a table that is 0.8 meter above the ground. The EUT is set 3 meters away from the transmitting antenna that is mounted on an antenna tower. Both horizontal and vertical polarizations of the antenna are set on test. Each of the four sides of EUT must be faced this transmitting antenna and measured individually. In order to judge the EUT performance, a CCD camera is used to monitor the EUT.

5.6.2. All the scanning conditions are as follows:

Condition of Test	Remarks
1. Fielded Strength	3 V/m (Severity Level 2)
2. Radiated Signal	Modulated
3. Scanning Frequency	80 - 1000 MHz
4. Sweeping time of radiated	0.0015 decade/s
5. Dwell Time	1 Sec.

### 5.7. Test Results

**PASS.**

Detailed information, Please refer to the following page.

## RF Field Strength Susceptibility Test Results

EUT	: MAGNETIC LEVITATE FLOATING DISPLAY	Temperature	: 22°C
M/N	: PA-0702	Humidity	: 55%
Power Supply	: DC	Test Mode	: ON
Modulation: <input checked="" type="checkbox"/> AM <input type="checkbox"/> Pulse <input type="checkbox"/> None    1 KHz    80%			
Frequency Range: 80MHz to 1000 MHz			
Steps	#	/	%
	Horizontal		Vertical
Front	Pass		Pass
Right	Pass		Pass
Rear	Pass		Pass
Left	Pass		Pass
Test Equipment: See Clause 2.			
Note:			



## 6. MAGNETIC FIELD IMMUNITY TEST

### 6.1. Block Diagram of Test Setup

#### 6.1.1. Block Diagram of EUT Test Setup

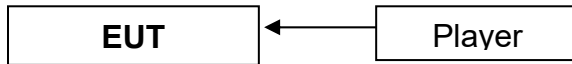

*(EUT:MAGNETIC LEVITATE FLOATING DISPLAY)*

#### 6.1.2. Block Diagram of Test Setup

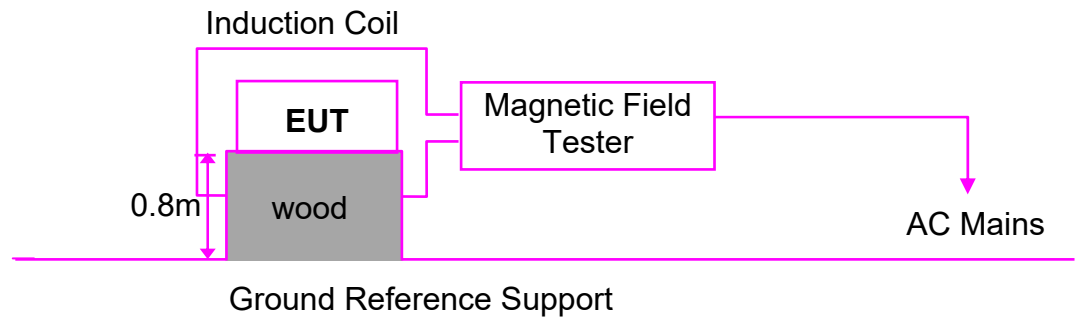

*(EUT:MAGNETIC LEVITATE FLOATING DISPLAY)*

### 6.2. Test Standard

EN 55024:2010/A1:2015 (EN 61000-4-8: 2010)

### 6.3. Severity Levels and Performance Criterion

Severity Level 2 at 3A/m

Severity Level:

Level	Magnetic Field Strength A/m
1.	1
2.	<b>3</b>
3.	10
4.	30
5.	100
X.	Special

Performance criterion: **A**

#### 6.4. EUT Configuration on Test

The configuration of EUT is listed in Section 3.4.

#### 6.5. Operating Condition of EUT

- 6.5.1. Setup the EUT as shown in Section 6.1.
- 6.5.2. Turn on the power of all equipments.
- 6.5.3. Let the EUT work in test mode and test it.

#### 6.6. Test Procedure

The EUT shall be subjected to the test magnetic field by using the induction coil of standard dimensions (1m\*1m) and shown in Section 6.1. 2. The induction coil shall then be rotated by 90° in order to expose the EUT to the test field with different orientations.

#### 6.7. Test Results

**PASS.**

Detailed information, Please refer to the following page.

## Magnetic Field Immunity Test Results

EUT	:	MAGNETIC LEVITATE FLOATING DISPLAY	Temperature	:	25°C
M/N	:	PA-0702	Humidity	:	55%
Power Supply	:	DC	Test Mode	:	ON
Test Level	Testing Duration	Coil Orientation	Criterion	Result	
3A/M	5 minutes	Horizontal	A	PASS	
3A/M	5 minutes	Vertical	A	PASS	
Remark:		Test Equipment: See Clause 2.			

## **APPENDIX I**

### **Radiated Emission Test Dat**

### Radiated Emission

Engineer : Andy	
EUT :MAGNETIC LEVITATE FLOATING DISPLAY	Time : 2018/04/26
Limit : EN 55032	Comment : 20°C/50%
MN: PA-0702	Note : Hor

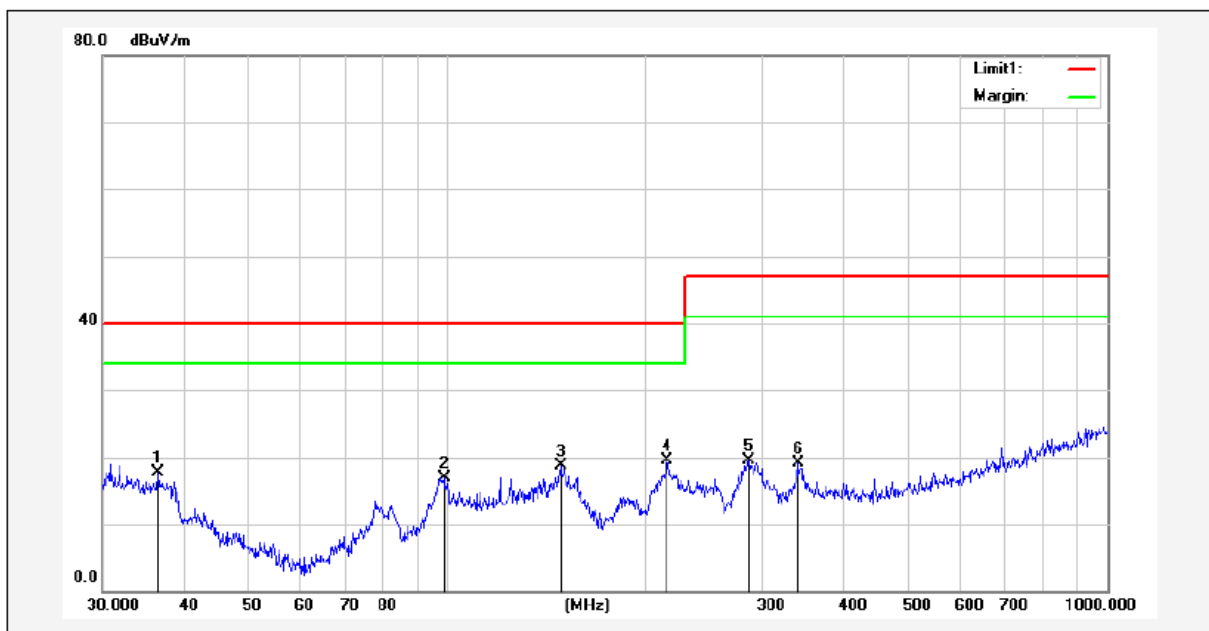

No.	Frequency (MHz)	Reading (dBuV)	Correction factor(dB/m)	Result (dBuV/m)	Limit (dBuV/m)	Margin (dB)	Degree (deg.)	Height (cm)	Remark
1	36.3814	30.92	-13.27	17.65	40.00	-22.35			peak
2	98.8326	35.26	-18.38	16.88	40.00	-23.12			peak
3	148.4410	34.09	-15.46	18.63	40.00	-21.37			peak
4*	215.2678	37.24	-17.72	19.52	40.00	-20.48			peak
5	285.9778	32.99	-13.44	19.55	47.00	-27.45			peak
6	339.5888	32.26	-13.11	19.15	47.00	-27.85			peak

### Radiated Emission

Engineer : Andy	
EUT :MAGNETIC LEVITATE FLOATING DISPLAY	Time : 2018/04/26
Limit : EN 55032	Comment : 22°C/55%
MN: PA-0702	Note : Ver

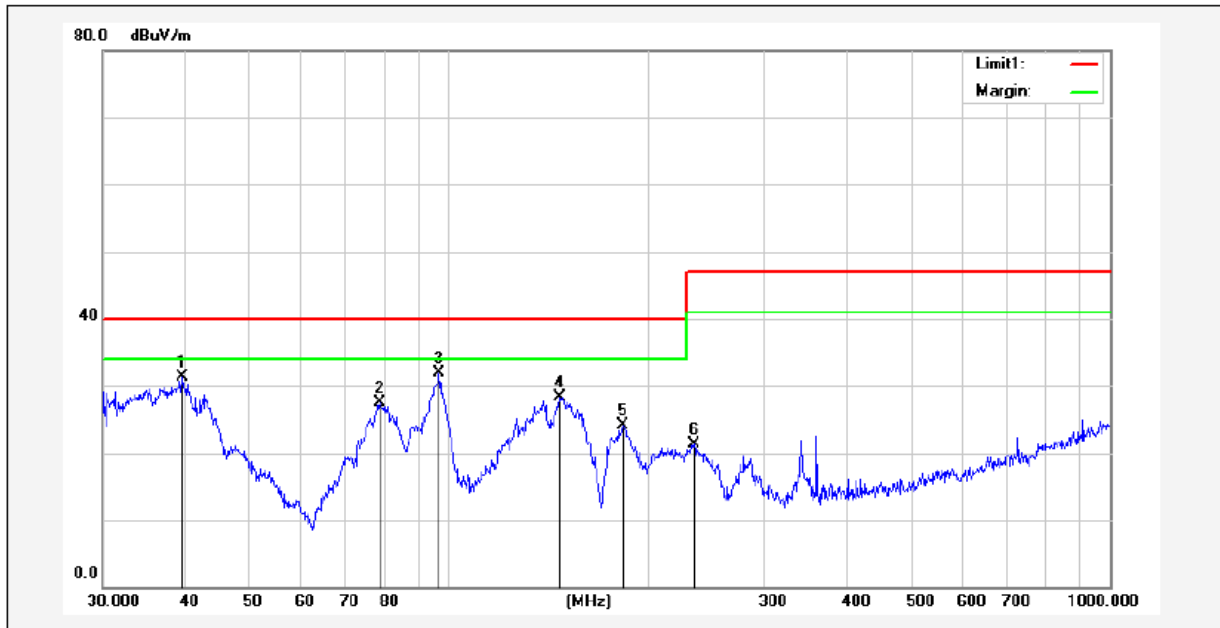

No.	Frequency (MHz)	Reading (dBuV)	Correction factor(dB/m)	Result (dBuV/m)	Limit (dBuV/m)	Margin (dB)	Degree (deg.)	Height (cm)	Remark
1	39.5757	46.87	-15.54	31.33	40.00	-8.67			peak
2	78.6888	49.64	-22.19	27.45	40.00	-12.55			peak
3*	96.7749	50.83	-18.89	31.94	40.00	-8.06			peak
4	147.4036	43.76	-15.41	28.35	40.00	-11.65			peak
5	183.8440	42.23	-18.04	24.19	40.00	-15.81			peak
6	234.9909	38.11	-16.79	21.32	47.00	-25.68			peak

## **APPENDIX II**

### **Photographs of the EUT**

FIGURE 1

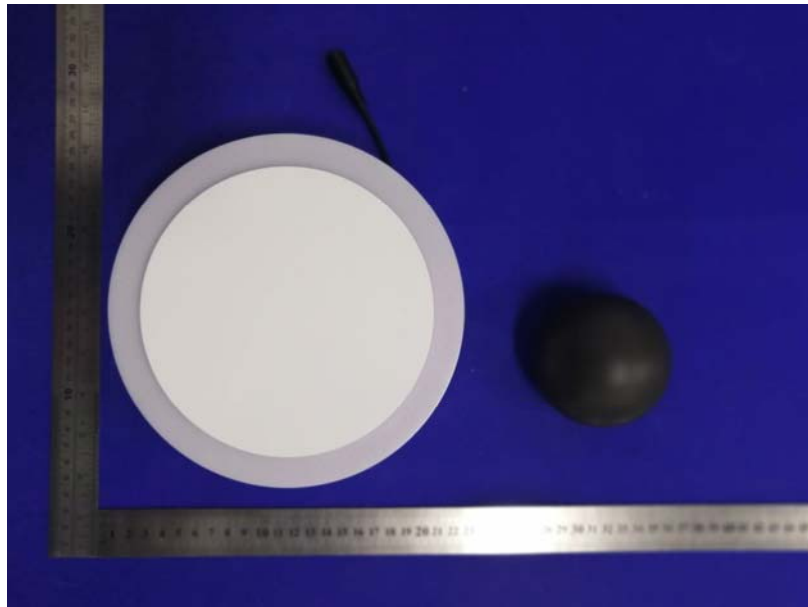

FIGURE 2

