

### FEATURES

- USB Type-C 1.4 and PD 3.0 compliant
- USB-IF Certified. TID: 875, XID: 5400
- Support SOP' communication
- Integrated transceiver (BMC PHY)
- Support both structured VDM version 1.0 and 2.0
- High integration
  - Embedded both side Ra resistors
  - Embedded both side VCONN diodes
  - Embedded MTP
- Different package options:
  - DFN-6L(HFBP-6L) 2mmx2mm, 0.65mm pitch
  - DFN-8L 2mmx3mm, 0.5mm pitch
  - WLCSP-6B, 0.875mmx1.425mm, 0.4mm pitch
- Support multiple times programming or fuse lock
- Compatible with third party programming tools
- Support 2.7V ~ 5.5V operation on VCONN1 and VCONN2 pins
- Custom structured VDM writing through CC pin
- Slew rate control for BMC signal to reduce EMI
- 25V high voltage protection on CC, VCONN1 and VCONN2 pins
- Support Thunderbolt 3 40Gbps data communication
- Support Get Manufacturer Info command
- ±8 kV HBM ESD on CC, VCONN1 and VCONN2 pins

### APPLICATIONS

- USB Type-C Cable ID

### GENERAL DESCRIPTION

**HUSB332** is a USB Type-C E-Marker for Cable ID applications. It is compliant with USB Type-C Specification Revision 1.4 and USB Power Delivery Specification Revision 3.0.

Powered from VCONN1 or VCONN2, **HUSB332** can determine to act as SOP'. The built-in MTP can be programmed through CC line or I<sup>2</sup>C bus so that it will be flexible for in-system programming.

The **HUSB332** operates over a wide supply range of 2.7 V to 5.5 V. It is available in DFN-6L(HFBP-6L), DFN-8L and WLCSP-6B packages. It is rated over the -40°C to +85°C temperature range.

### TYPICAL APPLICATION CIRCUIT

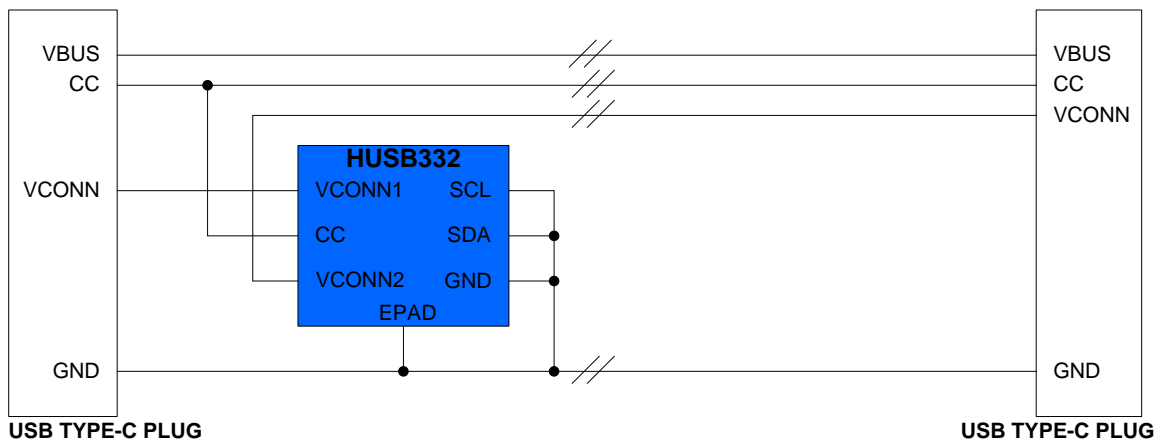

Figure 1. HUSB332 Application Diagram

**REVISION HISTORY**

<b>Version</b>	<b>Data</b>	<b>Description</b>
V1.0	June 8, 2019	Release version
V1.1	August 6, 2019	Update UVLO threshold
V1.2	September 6, 2019	Add DFN-8L package
V1.3	December 15, 2019	Add HUSB332_U22A
V1.4	May 5, 2020	Add WLCSP-6B package
V1.5	June 8, 2020	Update Figure 2, Figure 5 and Figure 6
V1.6	August 7, 2020	Update Package Dimension
V1.7	January 26, 2021	Add HFBP-6L package
V1.8	March 8, 2021	Add supply current in Table 1
V1.9	May, 2021	Update Ordering Guide Table

## Contents

Features.....	1
Applications .....	1
General Description .....	1
Typical Application Circuit.....	1
Revision History.....	2
Specifications.....	4
General Specifications .....	4
Absolute Maximum Ratings.....	5
Thermal Resistance.....	5
Maximum Power Dissipation.....	5
ESD Caution.....	5
Pin Configuration and Function Descriptions .....	6
Block Diagram .....	8
Application Information .....	9
Discover Identity.....	9
VDO Data .....	9
Package Outline Dimensions .....	11
Package Dimensions.....	11
Package Marking.....	13
Ordering Guide.....	14

**SPECIFICATIONS**

**GENERAL SPECIFICATIONS**

V<sub>DD</sub> = 5 V, T<sub>A</sub> = 25°C, unless otherwise noted.

**Table 1.**

Parameter	Symbol	Test Conditions	Min	Typ	Max	Unit
<b>GENERAL PARAMETERS</b>						
VCONN1/VCONN2 Voltage	V <sub>DD</sub>	Standby mode	2.7	5	5.5	V
Under-voltage Lockout	V <sub>DD_UVLO</sub>			2.6		V
Supply Current			1	2	3	mA
Operating Junction Temperature	T <sub>J</sub>		-40		125	°C
Operating Ambient Temperature	T <sub>A</sub>		-40		85	°C
<b>BMC COMMON PARAMETERS</b>						
Bit Rate	f <sub>BitRate</sub>		270	300	330	Kbps
<b>BMC TX PARAMETERS</b>						
Maximum Difference between the Bit-rate during the Part of the Packet Following the Preamble and the Reference Bit-rate.	ρ <sub>BitRate</sub>				0.25	%
Time to Cease Driving the Line after the And of the Last bit of the Frame.	t <sub>EndDriveBMC</sub>				23	μs
Fall Time	t <sub>Fall</sub>		300			ns
Time to cease driving the line after the final high-to-low transition.	t <sub>HoldLowBMC</sub>		1			μs
Time from the End of Last Bit of a Frame until the Start of the First bit of the Next Preamble.	t <sub>InterFrameGap</sub>		25			μs
Rise Time	t <sub>Rise</sub>		300			ns
Time Before the Start of the First Bit of the Preamble when the Transmitter shall Start Driving the Line.	t <sub>StartDrive</sub>		-1		1	μs
Voltage Swing	V <sub>Swing</sub>		1.05	1.125	1.2	V
Transmit Low Voltage			-75		75	mV
Transmitter Output Impedance	Z <sub>Driver</sub>		33	54	-	Ω
<b>BMC RX PARAMETERS</b>						
Power Cable Termination	R <sub>a</sub>		800		1200	Ω
Time Window for Detecting Bus Non-idle	t <sub>TransitionWindow</sub>		12		20	μs
Number to Count to Detect Bus Non-idle	n <sub>Count</sub>		3			
Time constant of a single pole filter to limit broad-band noise ingress	t <sub>RxFilter</sub>		100			ns
Receiver Input Impedance	Z <sub>BmcRx</sub>		10			MΩ

**ABSOLUTE MAXIMUM RATINGS**

**Table 2.**

Parameter	Rating
VCONN1, VCONN2 and CC to GND	-0.5V to +25V
NC Pins to GND	-0.5V to +3.6V
Storage Temperature Range	-65°C to +150°C
Operating Junction Temperature Range	-40°C to +125°C
ESD HBM (Human Body Model) on CC, VCONN1 and VCONN2 pins	±8 kV
ESD HBM (Human Body Model) on SDA and SCL pins	±5 kV
ESD MM (Machine Model)	200 V
Soldering Conditions	JEDEC J-STD-020

Stresses above those listed under Absolute Maximum Ratings may cause permanent damage to the device. This is a stress rating only; functional operation of the device at these or any other conditions above those indicated in the operational section of this specification is not implied. Exposure to absolute maximum rating conditions for extended periods may affect device reliability.

**THERMAL RESISTANCE**

$\theta_{JA}$  is specified for the worst-case conditions, that is, a device soldered in a circuit board for surface-mount packages.

**Table 3. Thermal Resistance**

Package Type	$\theta_{JA}$	$\theta_{JC}$	Unit
DFN-6L(HFBP-6L)	45.5	11.7	°C/W
DFN-8L	31.5	7.5	°C/W
WLCSP-6B	-	-	°C/W

**Maximum Power Dissipation**

The maximum safe power dissipation in the HUSB332 package is limited by the associated rise in junction temperature ( $T_J$ ) on the die. At approximately 150°C, which is the glass transition temperature, the plastic changes its properties. Even temporarily exceeding this temperature limit may change the stresses that the package exerts on the die, permanently shifting the parametric performance of the HUSB332. Exceeding a junction temperature of 175°C for an extended period of time can result in changes in the silicon devices that potentially cause failure.

**ESD CAUTION**



**ESD (electrostatic discharge) sensitive device.** Charged devices and circuit boards can discharge without detection. Although this product features patented or proprietary protection circuitry, damage may occur on devices subjected to high energy ESD. Therefore, proper ESD precautions should be taken to avoid performance degradation or loss of functionality.

PIN CONFIGURATION AND FUNCTION DESCRIPTIONS

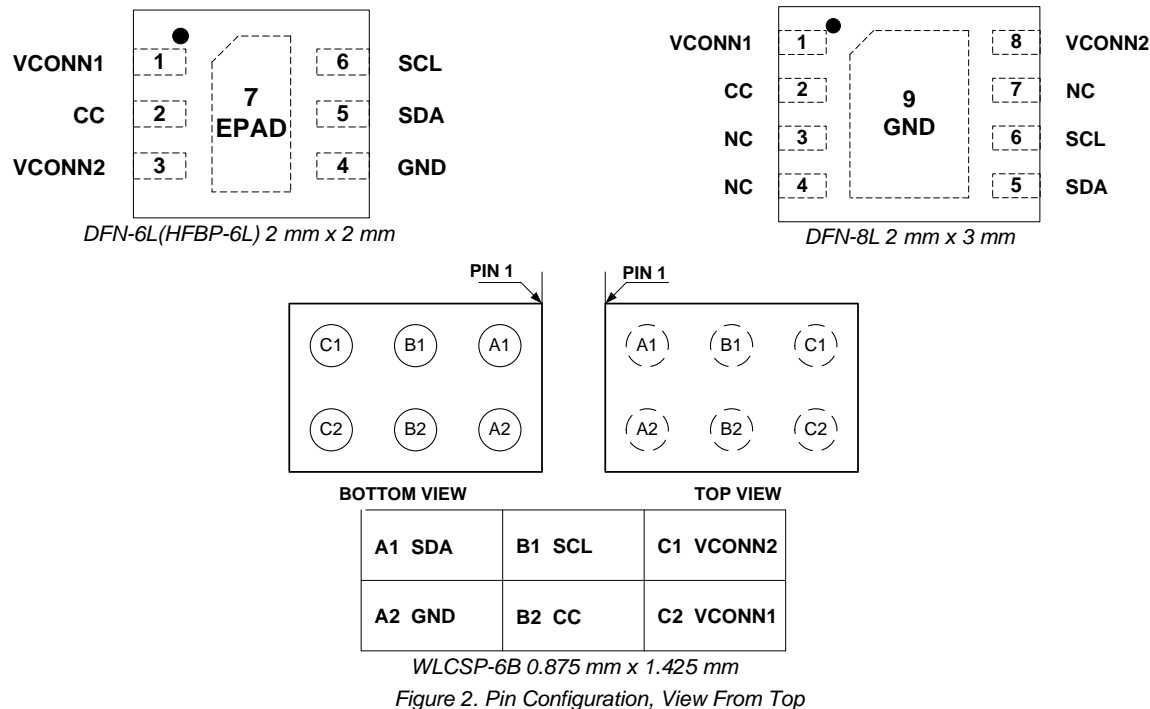

Table 4. DFN-6L(HFBP-6L) Pin Function Descriptions

Pin No.	Pin Name	Pin Description
1	VCONN1	The input pin supplied from VCONN.
2	CC	Type-C CC line input and output
3	VCONN2	The input pin supplied from the other side VCONN.
4	GND	Ground.
5	SDA	This Pin is Only Used for Debug. Please connect it to ground.
6	SCL	This Pin is Only Used for Debug. Please connect it to ground.
7	EPAD	Exposed pad.

Table 5. DFN-8L Pin Function Descriptions

Pin No.	Pin Name	Pin Description
1	VCONN1	The input pin supplied from VCONN.
2	CC	Type-C CC line input and output
3	NC	Not connection
4	NC	Not connection
5	SDA	This Pin is Only Used for Debug. Please connect it to ground.
6	SCL	This Pin is Only Used for Debug. Please connect it to ground.
7	NC	Not connection
8	VCONN2	The input pin supplied from the other side VCONN.

9	EPAD	Exposed pad used as GND pin.
---	------	------------------------------

**Table 6. WLCSP-6B Pin Function Descriptions**

Pin No.	Pin Name	Pin Description
A1	SDA	This Pin is Only Used for Debug. Please connect it to ground.
A2	GND	Ground.
B1	SCL	This Pin is Only Used for Debug. Please connect it to ground.
B2	CC	Type-C CC line input and output
C1	VCONN2	The input pin supplied from the other side VCONN.
C2	VCONN1	The input pin supplied from VCONN.

BLOCK DIAGRAM

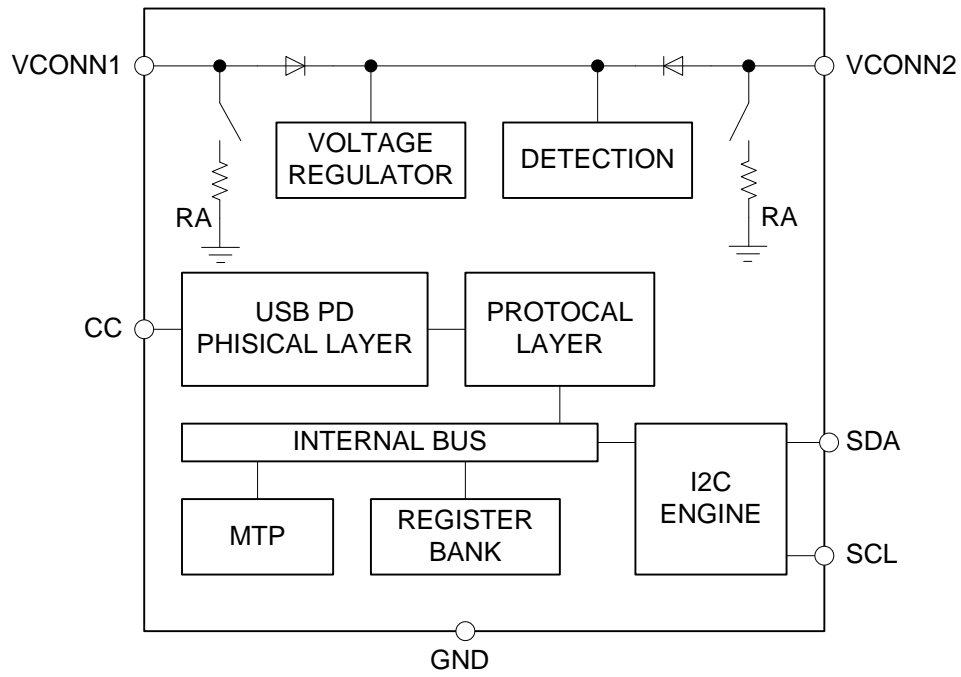

Figure 3. HUSB332 Block Diagram



# APPLICATION INFORMATION

## DISCOVER IDENTITY

The Discover Identity Command is provided to enable an Initiator (DFP) to identify its Port Partner and for an Initiator (VCONN Source) to identify the Responder (Cable Plug). The Discovery Identity Command is also used to determine whether a Cable Plug is PD-Capable by looking for a GoodCRC Message Response.

The Discover Identity Command shall be used to determine whether a given Cable Plug is PD. In this case a Discover Identity Command request sent to SOP' shall not cause a Soft Reset if a GoodCRC Message response is not returned since this can indicate a non-PD Capable cable. Note that a Cable Plug will not be ready for PD Communication until 50 ms after VCONN has been applied. During Cable Plug discovery, when there is an Explicit Contract, Discover Identity Commands are sent at a rate defined by the DiscoverIdentityTimer up to a maximum of nDiscoverIdentityCount times. See USB Power Delivery Specification Revision 3.0, Version 1.1 for details.

A PD-Capable Cable Plug shall return a Discover Identity Command ACK in response to a Discover Identity Command request sent to SOP'.

The Number of Data Objects field in the Message Header in the Discover Identity Command request shall be set to 1 since the Discover Identity Command request shall not contain any VDOs.

The Discover Identity Command ACK sent back by the Responder shall contain an ID Header VDO, a Cert Stat VDO, a Product VDO and the Product Type VDOs defined by the Product Type as shown in Figure 4.

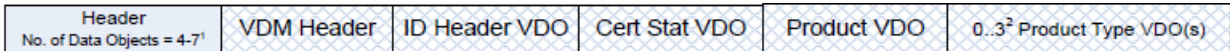

Figure 4. Discover Identify Command Response

## VDO DATA

Table 7. VDO Map

Bit(s)	Field	Descriptions
<b>ID Header VDO</b>		
[31]	Data Capable as USB Host	USB Communications Capable as USB Host: <ul style="list-style-type: none"> <li>• Shall be set to one if the product is capable of enumerating USB Devices.</li> <li>• Shall be set to zero otherwise</li> </ul>
[30]	Data Capable as USB Device	USB Communications Capable as a USB Device: <ul style="list-style-type: none"> <li>• Shall be set to one if the product is capable of being enumerated as a USB Device.</li> <li>• Shall be set to zero otherwise</li> </ul>
[29:27]	Product Type Cable Plug	Product Type (Cable Plug): <ul style="list-style-type: none"> <li>• 000b – Undefined</li> <li>• 001b..010b – Reserved, shall not be used.</li> <li>• 011b – Passive Cable</li> <li>• 100b – Active Cable</li> <li>• 101b..111b – Reserved, shall not be used.</li> </ul>
[26]	Modal Operation Supported	Modal Operation Supported: <ul style="list-style-type: none"> <li>• Shall be set to one if the product supports Modal Operation.</li> <li>• Shall be set to zero otherwise</li> </ul>
[25:23]	Product type (DFP)	Product Type (DFP): <ul style="list-style-type: none"> <li>• 000b – Undefined</li> <li>• 001b – PDUSB Hub</li> <li>• 010b – PDUSB Host</li> <li>• 011b – Power Brick</li> <li>• 100b - Alternate Mode Controller (AMC)</li> <li>• 101b..111b – Reserved, shall not be used.</li> </ul>
[22:16]	Reserved	0
[15:0]	16-bit unsigned integer. USB vendor ID	USB-IF assigned VID
<b>Cert Stat VDO</b>		
[31:0]	32-bit unsigned integer, XID	Assigned by USB-IF
<b>Product VDO</b>		
[31:16]	16-bit unsigned integer. USB Product ID	Product ID assigned by Cable Vendor
[15:0]	16-bit unsigned integer .bcdDevices	Device Version assigned by Cable Vendor

Passive Cable VDO		
[31:28]	HW Version	0000b..1111b assigned by the VID owner
[27:24]	Firmware Version	0000b..1111b assigned by the VID owner
[23:21]	VDO Version	Version Number of the VDO (not this specification Version): • Version 1.0 = 000b Values 001b..111b are Reserved and shall not be used
[20]	Reserved	Shall be set to zero.
[19:18]	Type-C to USB Type-A/Type-B/Type-C/Captive	00: reserved 01: reserved 10: Type-C 11: Captive
[17]	Reserved	0
[16:13]	Cable Latency	0000b – Reserved, shall not be used 0001b – <10ns (~1m) 0010b – 10ns to 20ns (~2m) 0011b – 20ns to 30ns (~3m) 0100b – 30ns to 40ns (~4m) 0101b – 40ns to 50ns (~5m) 0110b – 50ns to 60ns (~6m) 0111b – 60ns to 70ns (~7m) 1000b – 1000ns (~100m) 1001b – 2000ns (~200m) 1010b – 3000ns (~300m) 1011b ....1111b Reserved, shall not be used Includes latency of electronics in Active Cable
[12:11]	Cable Termination Type	00b = VCONN not required. Cable Plugs that only support Discover Identity Commands shall set these bits to 00b. 01b = VCONN required 10b..11b = Reserved, shall not be used
[10:9]	Maximum VBUS Voltage	Maximum Cable VBUS Voltage: 00b – 20V 01b – 30V 10b – 40V 11b – 50V
[8:7]	Reserved	Shall be set to zero.
[6:5]	VBUS Current Handling Capability	00b = Reserved, shall not be used. 01b = 3A 10b = 5A 11b = Reserved, shall not be used.
[4]	VBUS Through Cable	0 = No 1 = Yes
[3]	Reserved.	Shall be set to 0.
[2:0]	USB SuperSpeed Signaling support	000b = USB 2.0 only, no SuperSpeed support 001b = [USB 3.2] Gen1 010b = [USB 3.2] / [USB 4] Gen2 011b = [USB 4] Gen3 100b.. 111b = Reserved, shall not be used See [USB Type-C 1.4] for definitions.

PACKAGE OUTLINE DIMENSIONS

PACKAGE DIMENSIONS

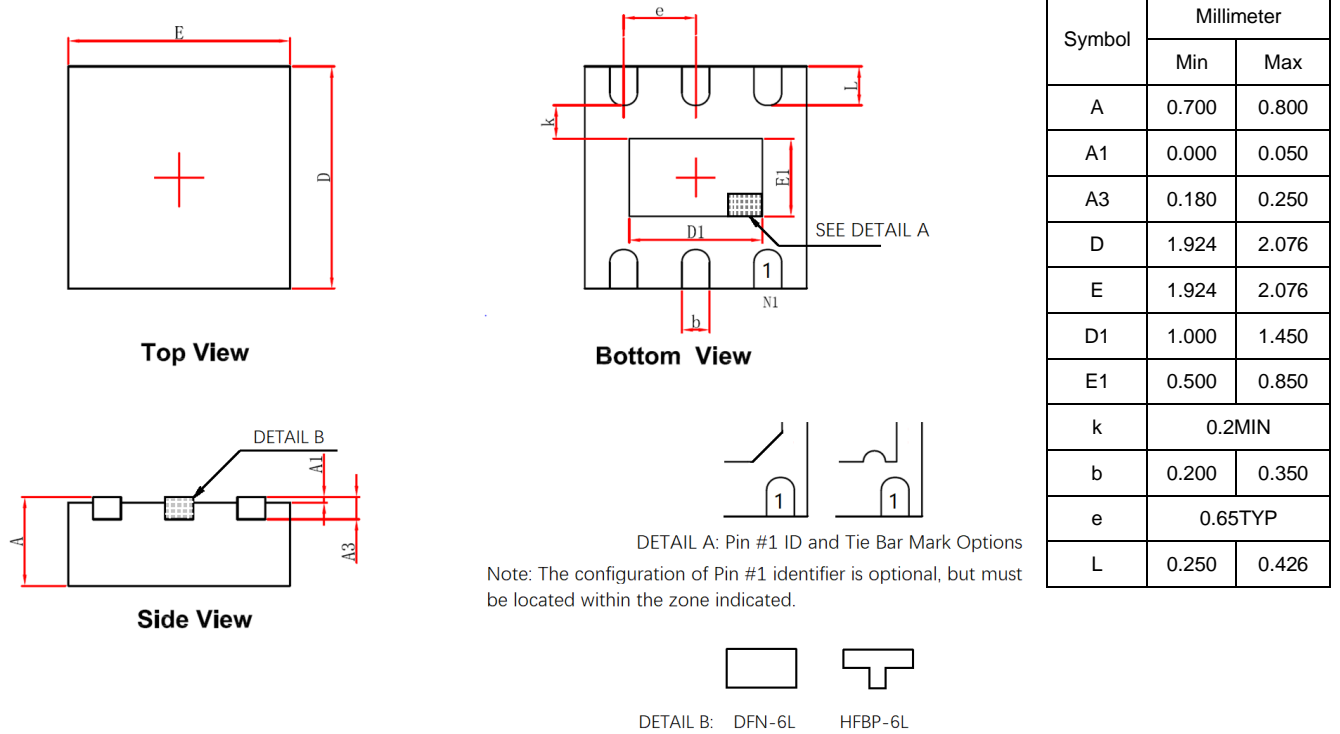
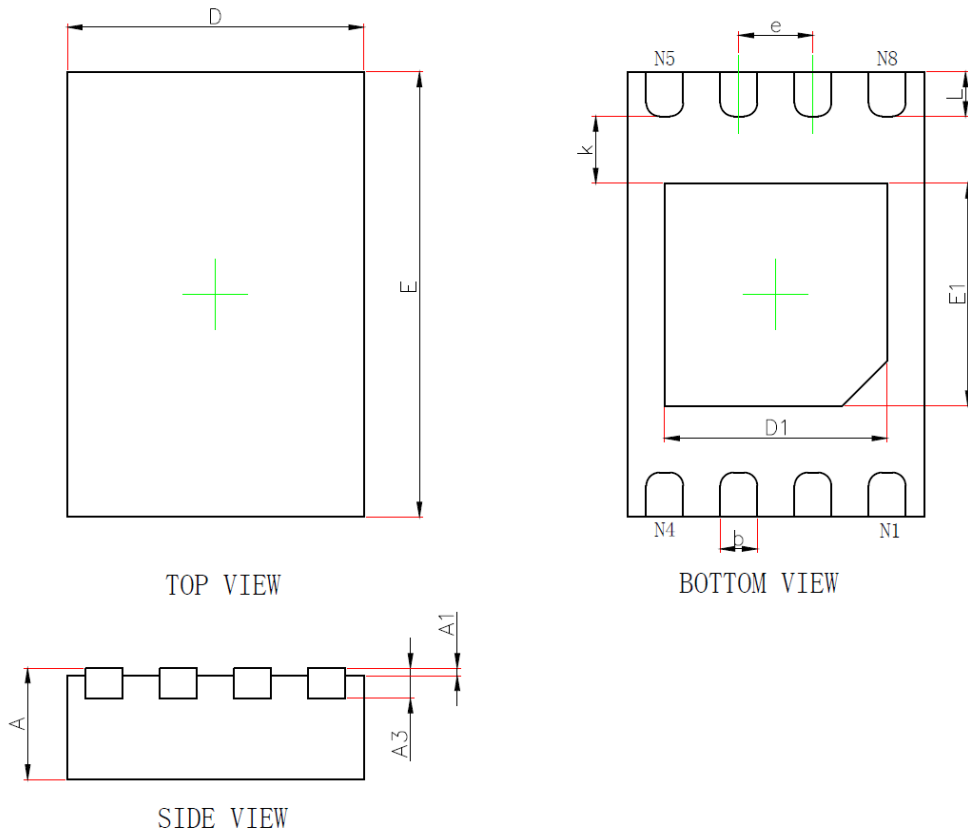

Figure 5. DFN-6L(HFBP-6L) Package, 2 mm x 2 mm Body



Symbol	Millimeter	
	Min	Max
A	0.700	0.800
A1	0.000	0.050
A3	0.180	0.250
D	1.900	2.100
E	2.900	3.100
D1	1.400	1.600
E1	1.400	1.600
k	0.2MIN	
b	0.180	0.300
e	0.500BSC	
L	0.224	0.500

Figure 6. DFN-8L Package, 2 mm x 3 mm Body

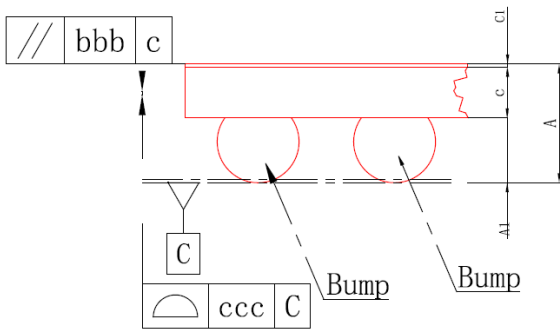
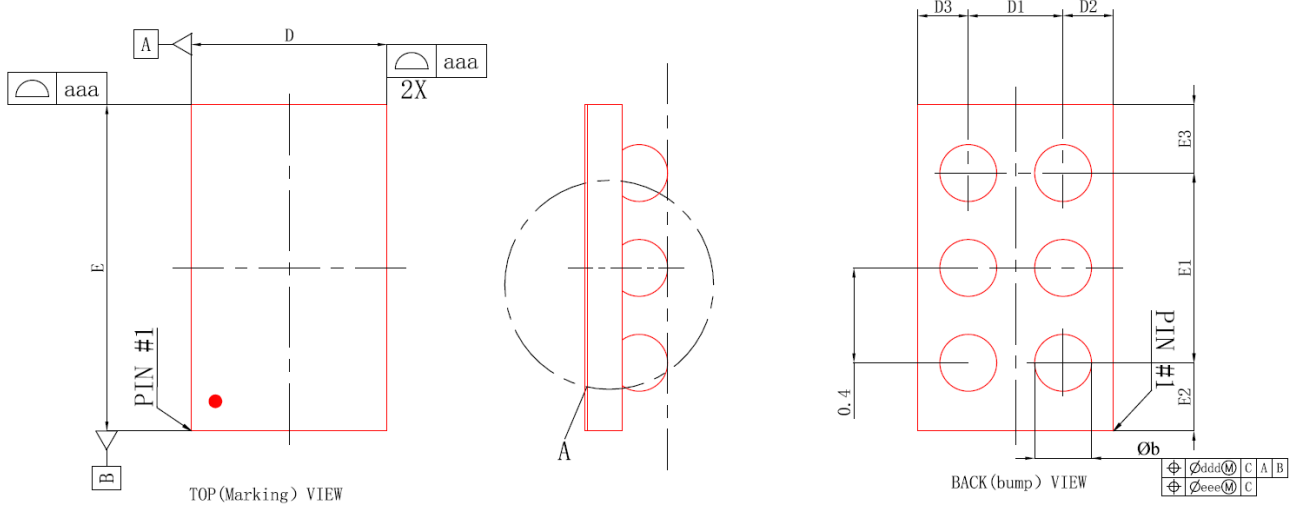

Figure 7. WLCSP-6B Package, 0.875 mm x 1.425 mm Body

PACKAGE MARKING

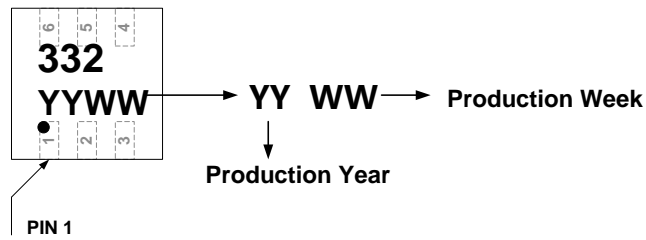

Figure 8. DFN-6L (HF6P-6L) Package Top Marking

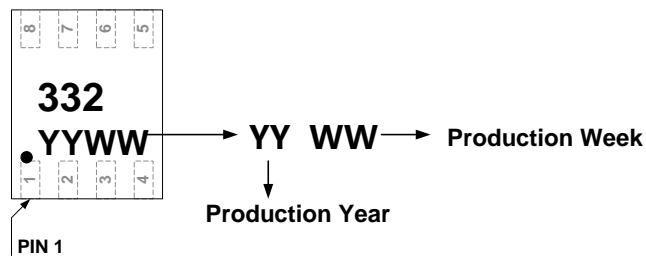

Figure 9. DFN-8L Package Top Marking

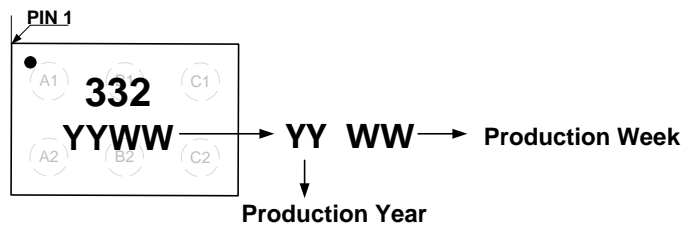

Figure 10. WLCSP-6B Package Top Marking

**ORDERING GUIDE**

Order Model	Description	Package	Ambient Temperature Range	Package Option
HUSB332_U31A	Default USB3.2 gen 2, 1m cable	DFN-6L	-40°C to +85°C	Tape & Reel, 4000
		HFBP-6L	-40°C to +85°C	Tape & Reel, 3000
HUSB332_U31B	Default USB3.2 gen 2, 1m cable	DFN-8L	-40°C to +85°C	Tape & Reel, 4000
HUSB332_U31C	Default USB3.2 gen 2, 1m cable	WLCSP-6B	-40°C to +85°C	Tape & Reel, 3000

**IMPORTANT NOTICE**

Hynetek Semiconductor Co., Ltd. and its subsidiaries (Hynetek) reserve the right to make corrections, enhancements, improvements and other changes to its semiconductor products and services per JESD46, latest issue, and to discontinue any product or service per JESD48, latest issue. Buyers should obtain the latest relevant information before placing orders and should verify that such information is current and complete. All semiconductor products (also referred to herein as "components") are sold subject to Hynetek's terms and conditions of sale supplied at the time of order acknowledgment.

Hynetek warrants performance of its components to the specifications applicable at the time of sale, in accordance with the warranty in Hynetek's terms and conditions of sale of semiconductor products. Testing and other quality control techniques are used to the extent Hynetek deems necessary to support this warranty. Except where mandated by applicable law, testing of all parameters of each component is not necessarily performed.

Hynetek assumes no liability for applications assistance or the design of Buyers' products. Buyers are responsible for their products and applications using Hynetek components. To minimize the risks associated with Buyers' products and applications, Buyers should provide adequate design and operating safeguards.

Hynetek does not warrant or represent that any license, either express or implied, is granted under any patent right, copyright, mask work right, or other intellectual property right relating to any combination, machine, or process in which Hynetek components or services are used. Information published by Hynetek regarding third-party products or services does not constitute a license to use such products or services or a warranty or endorsement thereof. Use of such information may require a license from a third party under the patents or other intellectual property of the third party, or a license from Hynetek under the patents or other intellectual property of Hynetek.

Reproduction of significant portions of Hynetek information in Hynetek data books or data sheets is permissible only if reproduction is without alteration and is accompanied by all associated warranties, conditions, limitations, and notices. Hynetek is not responsible or liable for such altered documentation. Information of third parties may be subject to additional restrictions.

Resale of Hynetek components or services with statements different from or beyond the parameters stated by Hynetek for that component or service voids all express and any implied warranties for the associated Hynetek component or service and is an unfair and deceptive business practice.

Hynetek is not responsible or liable for any such statements.

Buyer acknowledges and agrees that it is solely responsible for compliance with all legal, regulatory and safety-related requirements concerning its products, and any use of Hynetek components in its applications, notwithstanding any applications-related information or support that may be provided by Hynetek. Buyer represents and agrees that it has all the necessary expertise to create and implement safeguards which anticipate dangerous consequences of failures, monitor failures and their consequences, lessen the likelihood of failures that might cause harm and take appropriate remedial actions. Buyer will fully indemnify Hynetek and its representatives against any damages arising out of the use of any Hynetek components in safety-critical applications.

In some cases, Hynetek components may be promoted specifically to facilitate safety-related applications. With such components, Hynetek's goal is to help enable customers to design and create their own end-product solutions that meet applicable functional safety standards and requirements. Nonetheless, such components are subject to these terms.

No Hynetek components are authorized for use in FDA Class III (or similar life-critical medical equipment) unless authorized officers of the parties have executed a special agreement specifically governing such use.

Only those Hynetek components which Hynetek has specifically designated as military grade or "enhanced plastic" are designed and intended for use in military/aerospace applications or environments. Buyer acknowledges and agrees that any military or aerospace use of Hynetek components which have not been so designated is solely at the Buyer's risk, and that Buyer is solely responsible for compliance with all legal and regulatory requirements in connection with such use.

Hynetek has specifically designated certain components as meeting ISO/TS16949 requirements, mainly for automotive use. In any case of use of non-designated products, Hynetek will not be responsible for any failure to meet ISO/TS16949.

Please refer to below URL for other products and solutions of Hynetek Semiconductor Co., Ltd.

Address: Room 306, Building 4, Shenzhen Software Park, Gaoxin Mid 2nd Road,  
Nanshan District, Shenzhen, 518057 China.

[www.hynetek.com](http://www.hynetek.com)