



M-1030UVS

平圆两用 UV 固化机

使用说明书

Operation Instruction



Written by LCPM

LC Industrial company Limited 1-12

Website: [Http://www.lc-pm.com](http://www.lc-pm.com)

Online contact Skype: yingsuhuakelven QQ: 726986799

Email: sales@lcpadprinter.cn kelven@lcpadprinter.cn



M-1030UVS 是一款既可用于平面 UV 固化, 也可用于曲面体 UV 固化的专用设备, 广泛用于移印, 丝印, 喷涂等领域的 UV 装饰领域的油墨干燥, 它能够激发稳定的紫外光线, 引发 UV 感光材料的聚合反应.在化妆品, 塑料包装, 玩具等行业有出色表现.

Contents

| | |
|-----------------------------|---|
| 1. Dimensions----- | 1 |
| 2. Parameters----- | 2 |
| 3. Operation panel----- | 2 |
| 4. Operation procedure----- | 3 |
| 5. Cautions ----- | 4 |

目录

| | |
|--------------|-----|
| 1. 外形尺寸----- | 《1》 |
| 2. 技术参数----- | 《2》 |
| 3. 操作面板----- | 《3》 |
| 4. 操作步骤----- | 《4》 |
| 5. 注意事项----- | 《5》 |



外形结构图

Construction Drawing

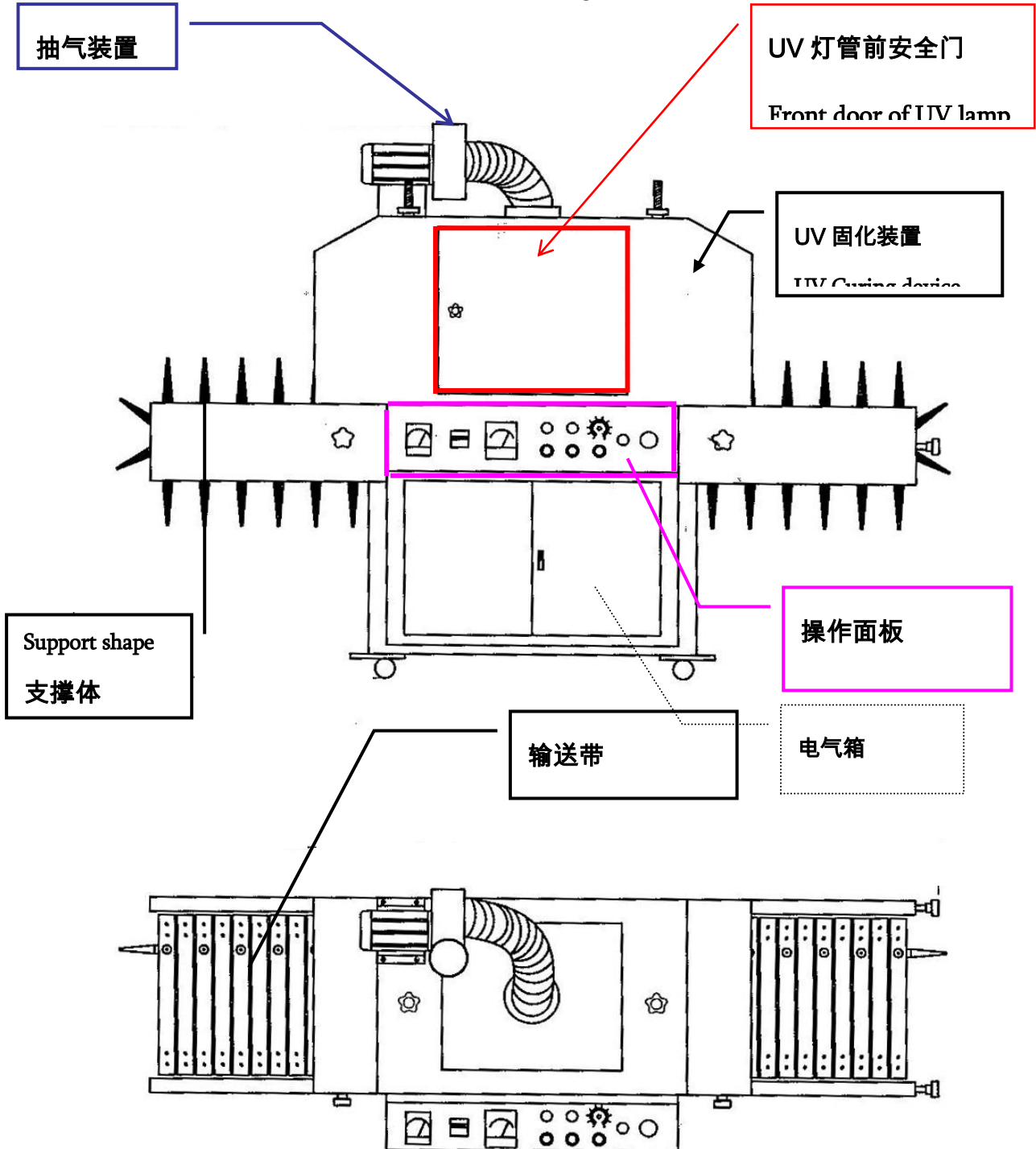

LC Industrial company Limited 3-12

Website: [Http://www.lc-pm.com](http://www.lc-pm.com)

Online contact Skype: yingsuhuakelven QQ: 726986799

Email: sales@lcpadprinter.cn kelven@lcpadprinter.cn



1. Parameters

技术参数

| | | | |
|--------------------------------|-----------|--------------|--------------------|
| Model | M-1030UVS | Curing speed | 1800~3000 pcs/HOUR |
| Container Mouth Diameter Range | φ 12~24MM | Power | 380v |
| Container height range | 20~300MM | Lamp wattage | 4000w |

| | | | |
|----------|-----------|------|-------------------|
| 机型号 | M-1030UVS | 固化速度 | 1800~3000pcs/HOUR |
| 适用的瓶口直径 | φ 12~24MM | 工作电源 | 380v |
| 适用的塑胶瓶高度 | 20~300MM | 灯管功率 | 4000w |

● Operation panel 操作面板

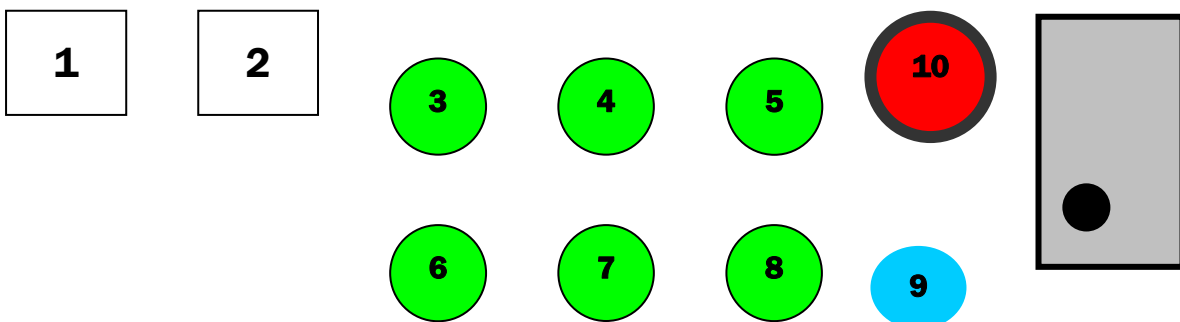

LC Industrial company Limited 4-12

Website: [Http://www.lc-pm.com](http://www.lc-pm.com)

Online contact Skype: yingsuhuakelven QQ: 726986799

Email: sales@lcpadprinter.cn kelven@lcpadprinter.cn



1. 电流表 Current Meter :

显示 UV 灯的工作电流

Indicates the electric current of the working lamp.

2. 计时器 Time Meter:

显示 UV 灯管的实际工作时间

Indicates the actual working hours of the UV lamp.

3. 半光显示灯 50% ray led

显示 UV 灯管是否在半光条件下, 如果指示灯亮, 表明 UV 灯半光工作

Indicates whether the UV lamp is working in the mode of half power. If it lights up, means the half power mode is on.

4. 75%光显示灯 75% ray led

显示 UV 灯管是否在 75%光条件下, 如果指示灯亮, 表明 UV 灯 75%光工作

Indicates whether the UV lamp is working in the mode of 75% power. If it lights up, means the 75% power mode is on.

5. 全光显示灯 Full ray led

显示 UV 灯管是否在全光条件下, 如果指示灯亮, 表明 UV 灯全光工作

Indicates whether the UV lamp is working in the mode of full power. If it lights up, means the full power mode is on.

6.半光开关 Half power button :

按下半光按钮 UV 灯管将工作在半光条件下。

Press the button and the half ray led light indicates UV lamp working in half power mode.

7. 75%光开关 75% power button :

按下半光按钮 UV 灯管将工作在 75%光条件下。

Press the button and the 75% ray led light indicates UV lamp working in 75% power mode.

8. 全光开关 Full power button :

按下全光按钮 UV 灯管将工作在全光条件下。

Press the button and the full ray led light indicates UV lamp working in full power mode.

9. 输送带开关 Belt button

按下此按钮则输送带可以输送

Press the button and the conveyer begin to move

10. 急停开关 STOP

出现紧急情况时按下此开关关机

Press it the machine stop running when in danger

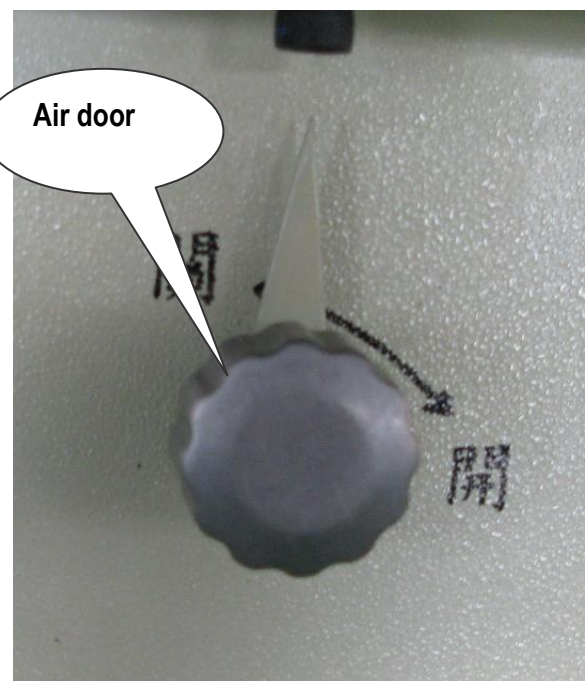



11. 调速器 SPEED SWITCHING

根据实际情况调整输送带输送速度

Adjusting conveyer speed according to curing condition

● Operation Procedure

操作步骤

1. *Open the side door, and turn the plastic knob on the top of the machine to adjust the distance between the UV lamp and the substrate to 120~180MM, after adjusting, close the door.*
2. *Connect the machine to the electrical source, and turn on the main switch.*
3. *Check whether the indication light (1)"CURRENT*

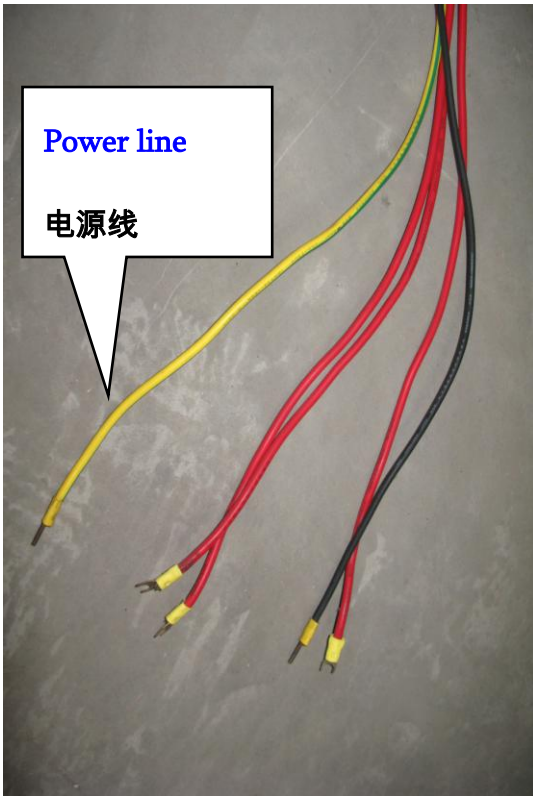

inks with the full brightness mode finally.

3. *Turn the two plastic knobs on both sides of the operation panel to set whether the taper supports for the containers revolve or not.*



METER" is on.

4. *Press the knob (9)"BELT CONTROLLER" to start the conveyor, and then turn the knob (11) to adjust the conveying speed in order to ensure the ink being cured completely.*
5. *Press the button (6)"HALF POWER " to adjust the UV lamp to the half brightness mode.*
6. *Checks whether the indication light (3)"HALF POWER "is on.*
7. *Only after the machine has been working in the half power mode for 2 minutes, can you press the button (7)"75% POWER" to start the 75% power mode .*
8. *Check whether the indication light (4)"75% POWER" is on.*
9. *Only after the machine has been working in the 75% power mode for 2 minutes, can you press the button (8)"FULL POWER" to start the full power mode .*
10. *After the exhaust is started (If the UV lamp is turned on ,the exhaust will be started automatically accordingly),you can begin your work.*
2. *If cures the colour processed substrate, you should cure the bottom ink with the half brightness mode first, then cure all*

LC Industrial company Limited 6-12

Website: [Http://www.lc-pm.com](http://www.lc-pm.com)

Online contact Skype: yingsuhuakelven QQ: 726986799

Email: sales@lcpadprinter.cn kelsen@lcpadprinter.cn

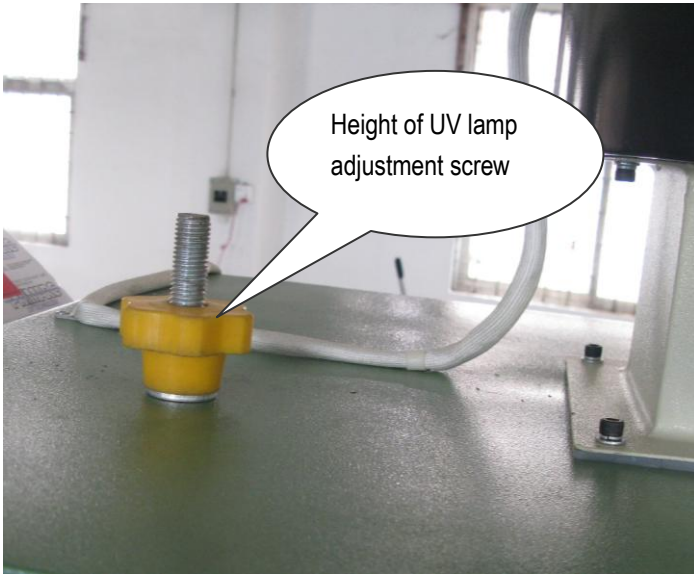

1. 打开安全门，旋转机顶的胶旋钮将 UV 灯管与印刷面距离调至 120~180MM，再关上安全门。
2. 接通电源，打开电源总开关。
3. 检查 (1) 电源显示灯是否处于接通状态。
4. 按 (9) 输送带起动按钮启动输送带，旋转输送带速度旋钮，以保证油墨

墨可得到完全固化。

5. 按 (6) 半光，开启半 UV 灯模式。
6. 检查 (3) 半光显示灯是否处于接通状态。
7. 待半光 2 分钟后方可启动 (7) 75% 光开关。检查 75% 光指示灯 (4) 是否点亮
8. 75% 光照模式启动后 2 分钟左右，方可启动全光 (8) 模式，并检查全光模式指示灯 (5) 是否点亮。

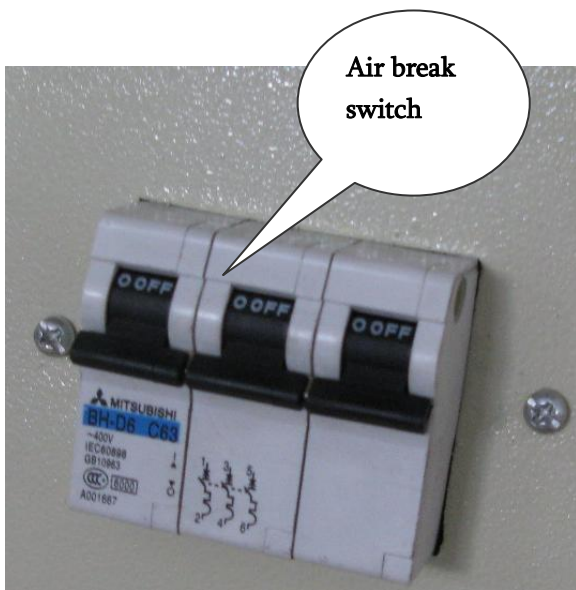

9. 检查 (5) 全光显示灯是否处于接通状态。
10. 待抽风系统启动后 (UV 灯开启后抽风机会自动启动)，可开始正式生产。
11. 如固化叠色类型的印刷品，应用使用半光固化底层油墨后，再用全光把所有油墨同时固化。
12. 转动控制面板两侧的胶旋错可调节顶瓶座旋



转或不转动。

● Installing UV lamp 安装 UV 灯管

在机器装运前，UV 灯管单独包装，客户需要使用前需要自行安装，UV 灯管使用 1000 小时后，通常要更管 UV 灯管，请按照下述步骤进行更换。

To avoid The UV lamp broken, UV lamp do not install on the machine, after using UV lamp for 1000 hours, You need to change UV lamp, Please installing or replacing UV lamp base on the below process.

1. 打开 UV 灯管后安全门。Please open the back door of UV lamp.

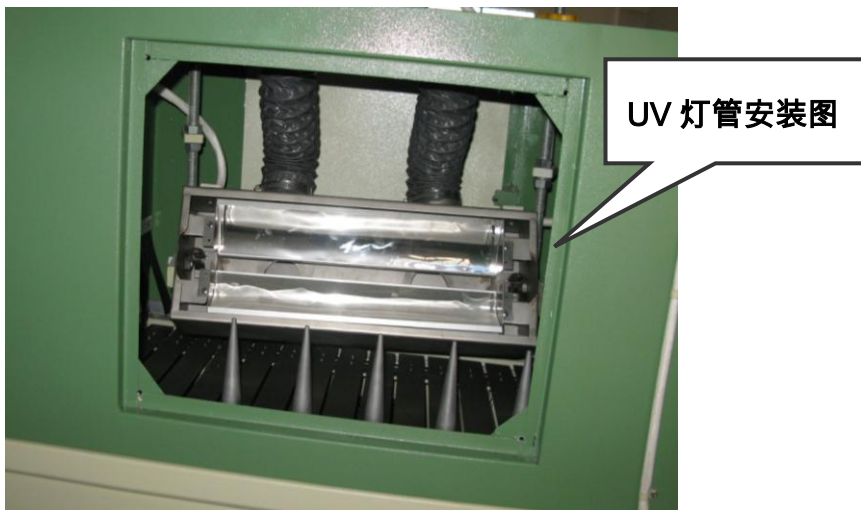

2. 将单独包装的 UV 灯管取出检查，安装在反射罩中。

Installing UV lamp on the reflection cover.

3. 调整 UV 灯管的平行度和高度。

Please adjust the height and parallelism of UV lamp.

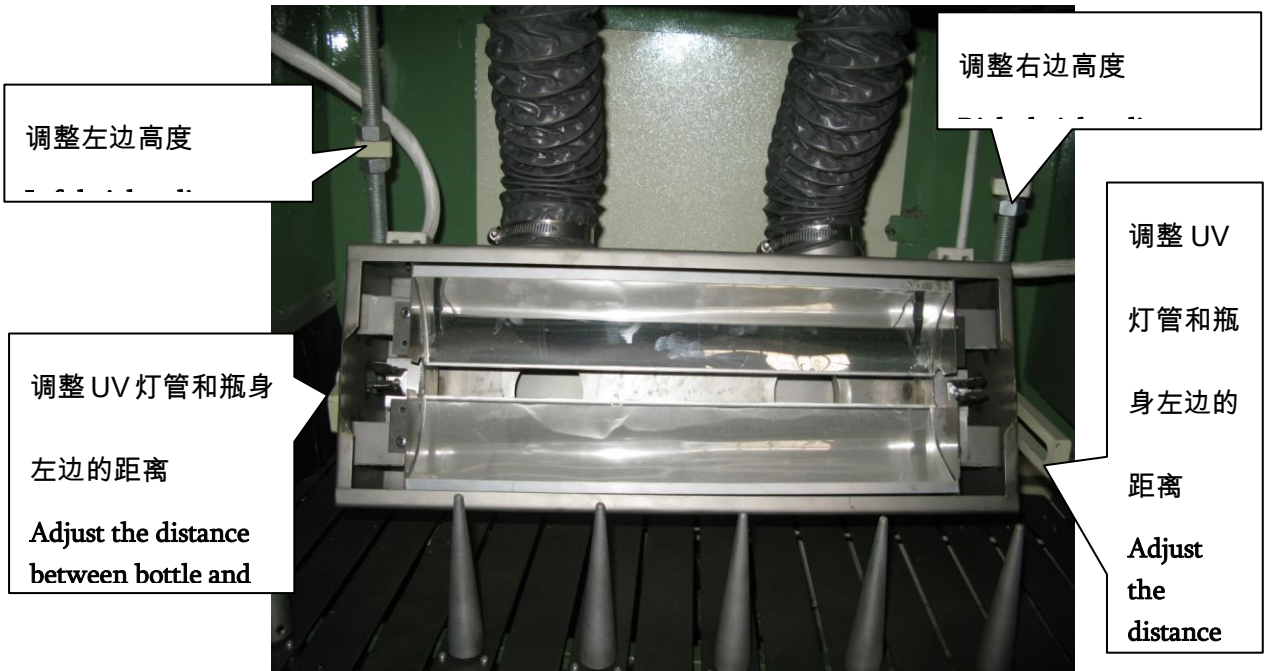
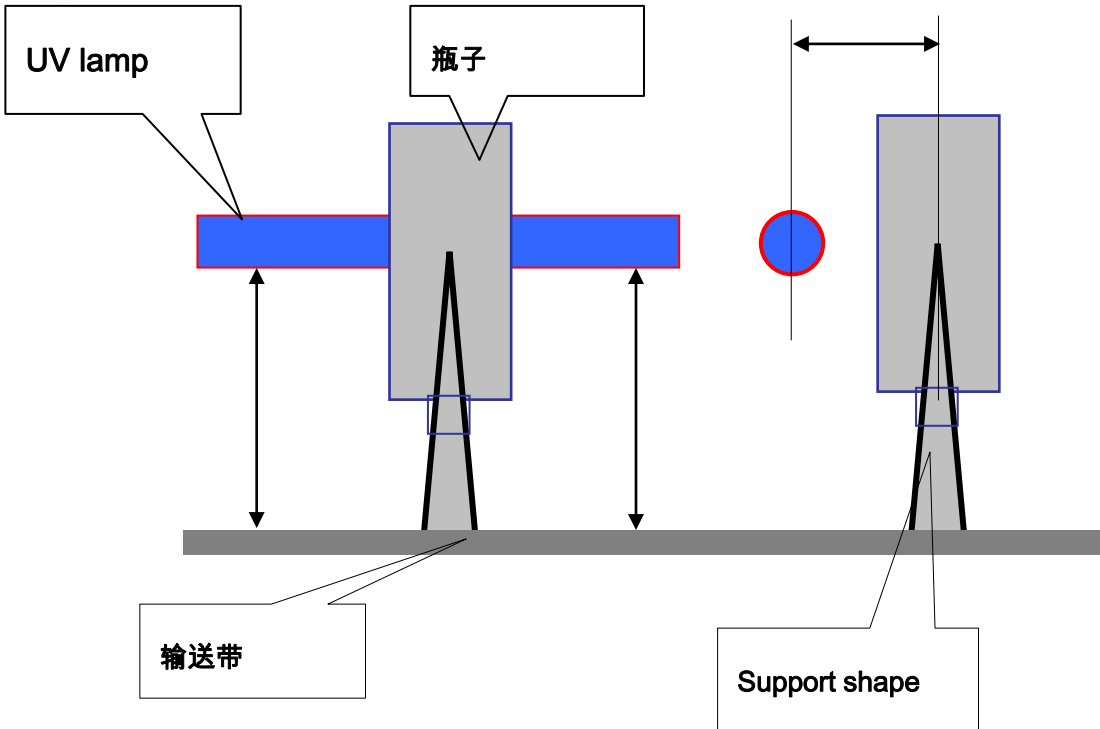



Cautions 注意事项

1. *While the UV lamp is working, it is strictly forbidden to open the side door to look into.*
2. *High voltage inside, it is dangerous. You must disconnect the power supply before replacing the lamp.*
3. *Ensure the ventilation in the workshop in order to prevent the volatile gas from accumulating excessively.*
4. *It is strictly forbidden to expose any part of your body in the ultraviolet radiation; otherwise skin will be burnt.*
5. *Do not look at the working UV lamp without wearing the protective eyeglasses beforehand; otherwise eyes will be injured.*

1. UV 灯管处于工作状态时，严禁打开安全门观看。
2. 高压危险，更换 UV 灯管前必须切断电源。
3. 保持工作间的空气流通，防止挥发气体过量积聚。
4. 严禁身体任何部分直接暴露在强烈的紫外光下，否则会灼伤皮肤。
5. 没带防护眼镜不能直接望工作中的灯管,否则强光会刺伤眼睛。



● 电路控制图
Circuit controlling

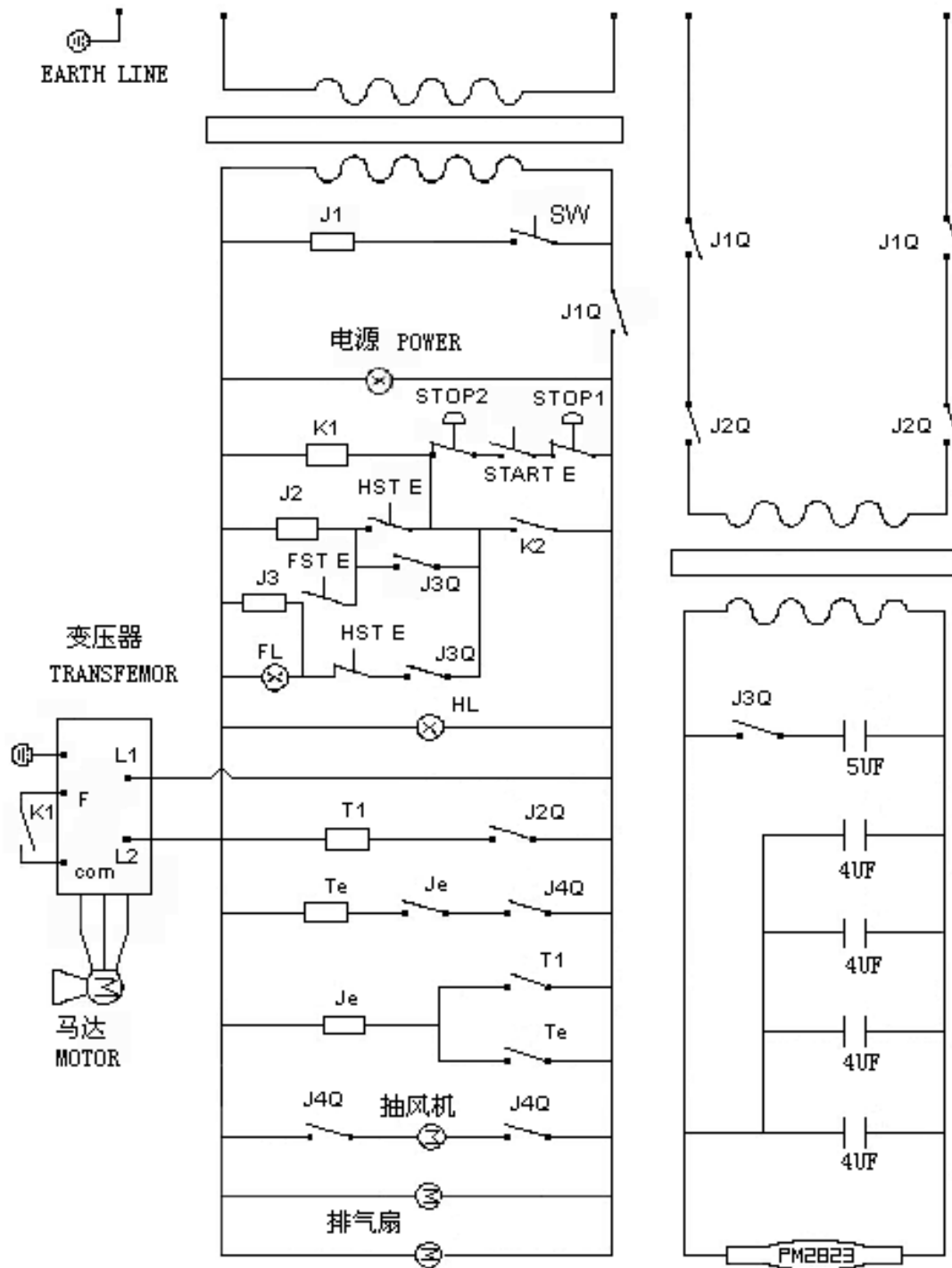



● 机器调整

Machine adjustment

1. Conveyor speed adjustment 输送带速度调整

将瓶子放于输送带的支撑体上面，启动机器，调整输送带的速度，待 UV 油墨彻底固化后，输送带的速度就是最佳速度，如果固化不彻底，就放慢输送带的速度。

2. Conveyor parallelism adjustment. 输送带平行度调整。

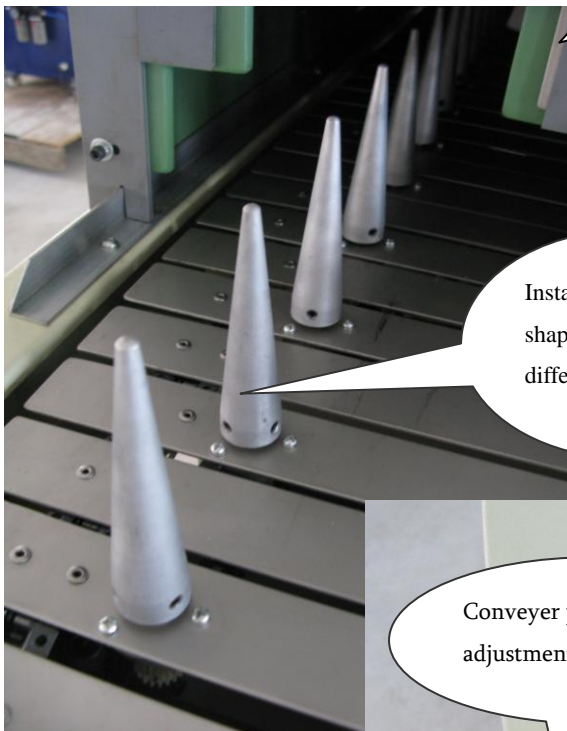

根据瓶子的外部尺寸，调整输送带进料口的宽度和高度，保证瓶子能够自由进入固化装置。

Please adjust the height and width of entering mouth of Conveyor so that the bottles can be entered freely.

Installing different shape according to different bottles.

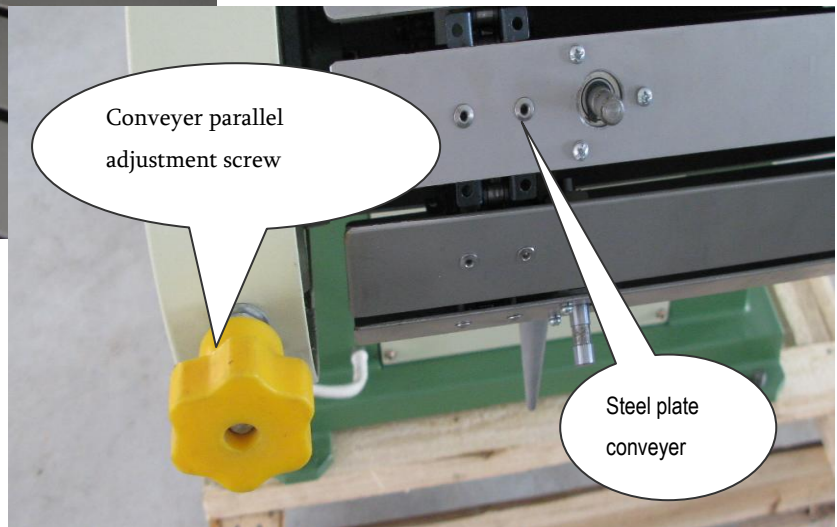

Conveyer parallel adjustment screw

Steel plate conveyer

4. Whirling speed of bottle. 瓶子旋转速度的调整。

机器操作面板两侧有两个黄色的旋钮，调节这两个旋钮可以调节输送带支撑体的旋转位置和速度，

LC Industrial company Limited 12-12

Website: [Http://www.lc-pm.com](http://www.lc-pm.com)

Online contact Skype: yingsuhuakelven QQ: 726986799

Email: sales@lcpadprinter.cn kelven@lcpadprinter.cn