

# G36

## SELF POWERED TOTALIZER / RATEMETER

- LARGE LCD DISPLAY (11mm Digit Size)
- 10kHz Count Speed
- PRESCALE FEATURE
- DECIMAL POINT POSITION SETTING
- FREE WRITE FEATURE
- DUST & SPLASH PROTECTION FRONT PANEL



### ■ MODELS

MODEL	TYPE	INPUT METHOD	INPUT TYPE	NO. OF DIGITS	PRESCALE
G36 - 101	Totalizer	Count Up	Contact / Open Collector / Voltage	8	NO
G36 - 102		90° Quadrature	Voltage		YES
G36 - 103		Count Up/Down	Contact / Open Collector		YES
G36 - 104			Voltage		YES
G36 - 201	Ratemeter	1 Input	Contact / Open Collector / Voltage	4/5 <sup>*1</sup>	YES
G36 - 301	Totalizer / Ratemeter	1 Input	Contact / Open Collector / Voltage	Totalizer : 8 Ratemeter : 4/5 <sup>*1</sup>	YES

### ■ SPECIFICATIONS

MODEL	G36 - 101	G36 - 102	G36 - 103	G36 - 104	G36 - 201	G36 - 301
TYPE	Totalizer				Ratemeter	Totalizer / Ratemeter
DISPLAY	8 Digits LCD (7 digits for G36-102~104 when count value is negative)				4/5 Digits LCD <sup>*1</sup>	Totalizer : 8 Dig. LCD Ratemeter: 4/5 <sup>*1</sup> LCD
COUNT MODE	Add	Add/Subtract 90° Quadrature	Add/Subtract (Individual input)		Rate Measurement	Add / Rate Measurement
INPUT TYPE	Contact/Open Collector/Voltage	Voltage	Contact/ Open Collector	Voltage	Contact/Open Collector/ Voltage	
INPUT SIGNAL	Contact : Relay, Microswitch, Open Collector			Voltage : L: 0~0.5VDC / H: 2~15VDC		
COUNT SPEED	Contact/Open Collector : 25Hz			Voltage : 10kHz		
PULSE WIDTH	Contact/Open Collector : On/Off 20ms			Voltage : On/Off 50μs		
RESET	Front Reset (push button), Remote Reset				—	Front Reset (push button), Remote Reset
BATTERY LIFE	5 years (at 25°C continuous)					
POWER SUPPLY	Self Powered (3V Lithium Battery) (Matsushita brand BR2/3A or Fuji Denki CR2/38L(N2) recommended) <sup>*2</sup>					
PRESCALE	—	0.0001 ~ 100.0000			0.001 ~ 9999	Totalizer : 0.0001~100.0000 Ratemeter: 0.001~9999
DECIMAL POSITION	—	4 positions			3 positions	Totalizer : 4 positions Ratemeter: 3 positions
RATEMETER SPECIFICATION	—				Accuracy: ± 0.2% Refresh rate: 0.7s min Zero Time: 10s	
CONNECTION	M3 Terminal Screw					
PROTECTION	Front Panel: Dust proof and Splash proof (when mounted with gasket)					
OPERATING TEMPERATURE	-5 ~ +40°C (non-freezing)					
OPERATING HUMIDITY	45 ~ 85% RH (non-condensing)					
WEIGHT	approx. 65g					







<sup>\*1</sup> Normal programming of the unit shows 4 digits of calculated value. However, when rate is set at x10, display shows 5 digits with fixed "0".

<sup>\*2</sup> Replacement batteries are available for sale from Line Seiki.









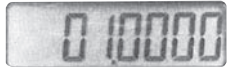
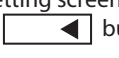

## ■ OPERATING PROCEDURE

TOTALIZER	G36 - 101, 102, 103, 104	
	<p><b>G36-101 Without Prescale</b> The front reset button comes disabled from the factory. To enable the front reset button, install a jumper wire between Terminals ⑤ and ①.</p>	
		<p><b>G36-102,103,104 With Prescale</b> To enter Program Mode, connect Terminals ⑤ and ① using a jumper wire. After program settings are entered, disconnect the jumper wire to save settings and display will go back to Count Mode.</p>

## ■ BUTTON FUNCTIONS (For models G36-102,103,104 only)

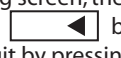
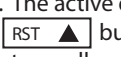
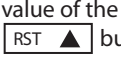
BUTTON	PROGRAM MODE	COUNT MODE
	This button is used to move the cursor from one digit to another. The active digit is indicated by a blinking display.	NOT APPLICABLE
	This button is used to set the desired value of each digit. Keeping this button depressed will cause numbers to autoscroll. This button is also used to set other program settings like Front Reset enable/disable and Decimal Point Position.	RESET COUNT VALUE
  	<p>By pressing  button while keeping the  button depressed, the display will scroll from one program screen to another. The order of scroll is as shown:</p> <pre> graph TD     A[0 10000] --&gt; B[000000]     B --&gt; C[P 000000]     C --&gt; D[R]     D --&gt; A           </pre> <p>Prescale Factor setting Decimal Point Position setting Free Write Value setting Front Reset Enable/Disable setting</p>	NOT APPLICABLE

## ■ PROGRAMMING PROCEDURE (For models G36-102,103,104 only)

PROGRAM	PROGRAM SCREEN	SETTING PROCEDURE
PRESCALE SETTING		When the display shows the Prescale Factor setting screen, the right most digit will blink. Choose the digit to set by pressing the  button. The active digit will blink. Set the desired value of the chosen digit by pressing the  button. Depressing the  button will cause the value to auto scroll.
DECIMAL POINT POSITION SETTING		When the display shows the Decimal Point Position setting screen, press the  button until the desired decimal point position is reached.
FREE WRITE SETTING		Free Write allows the counter to reset to a Free Write value other than zero. When the display shows the Free Write setting screen, the right most digit will blink. Choose the digit to set by pressing the  button. The active digit will blink. Set the desired value of the chosen digit by pressing the  button. Depressing the  button will cause the value to auto scroll.
FRONT RESET SETTING		When the display shows the Front Reset setting screen, choose the desired setting of the Front Reset by pressing the  button. A  display indicates an enabled front reset. A  display indicates a disabled front reset. Note: The remote reset is still active even if front reset setting is disabled.

## ■ OPERATING PROCEDURE

**RATEMETER** G36 - 201



To enter Program Mode, connect Terminals ③ and ① using a jumper wire. After program settings are entered, disconnect the jumper wire to save settings and display will go back to Count Mode.

## ■ BUTTON FUNCTIONS

BUTTON	PROGRAM MODE	COUNT MODE
	This button is used to move the cursor from one digit to another. The active digit is indicated by a blinking display.	NOT APPLICABLE
	This button is used to set the desired value of each digit. Keeping this button depressed will cause numbers to autoscroll. This button is also used to set other program settings like Decimal Point Position and Rate Display Multiplier.	NOT APPLICABLE
 + 	By pressing  button while keeping the  button depressed, the display will scroll from one program screen to another. The order of scroll is as shown:  	NOT APPLICABLE

## ■ PROGRAMMING PROCEDURE

PROGRAM	PROGRAM SCREEN	SETTING PROCEDURE
RATEMETER PRESCALE SETTING		When in the Ratemeter Prescale setting screen, when a  appears on the right most of the display, it is time to set the decimal point position for the prescale factor. Press the  button until decimal point is in desired position. Note: This decimal point is used only for the prescale factor and it will not appear on the ratemeter screen.
DECIMAL POINT POSITION SETTING		In this program mode screen, the Decimal Point Position for the ratemeter run mode display is set. When in this screen mode, press the  button to move the decimal point in the desired location.
RATE DISPLAY MULTIPLIER (x1 / x10)		In this program mode screen, it is used to select the Rate Display Multiplier. Selecting x10 will add a zero on the last digit of the display. This zero will not change value and will not affect the decimal point position. When in this screen mode, press the  button to select x1 or x10. When "1" is displayed, it is x1. When "10" is displayed, it is x10.







## OPERATING PROCEDURE

<b>TOTALIZER / RATEMETER</b> G36 - 301	
	<p>Two displays are available, Totalizer and Ratemeter displays. To toggle between displays, press the <b>T/R ◀</b> button.</p> <p>To enter Program Mode, connect Terminals ⑤ and ① using a jumper wire. After program settings are entered, disconnect the jumper wire to save settings and display will go back to Count Mode.</p>
TOTALIZER DISPLAY	RATEMETER DISPLAY

## BUTTON FUNCTIONS

BUTTON	PROGRAM MODE	COUNT MODE
<b>T/R ◀</b>	This button is used to move the cursor from one digit to another. The active digit is indicated by a blinking display.	This button is used to toggle the display between Totalizer and Ratemeter displays.
<b>RST ▲</b>	This button is used to set the desired value of each digit. Keeping this button depressed will cause numbers to autoscroll. This button is also used to set other program settings like Front Reset enable/disable, Rate Display Multiplier, etc.	This button will reset the the Totalizer. The ratemeter will not be affected by this button.
<b>T/R ◀</b> + <b>RST ▲</b>	By pressing <b>RST ▲</b> button repeatedly while keeping the <b>T/R ◀</b> button depressed, the display will scroll from one program screen to another. There are 6 program screens each indicated by a number on the left most of the display.	NOT APPLICABLE

## PROGRAMMING PROCEDURE

PROGRAM	PROGRAM SCREEN	SETTING PROCEDURE
(1) TOTALIZER PRESCALE SETTING	<div style="display: flex; justify-content: space-between; font-size: small;"> <span>Program No.</span> <span>Program Item</span> </div> 	<p>When the display shows the Prescale Factor setting screen, the right most digit will blink. Choose the digit to set by pressing the <b>T/R ◀</b> button. The active digit will blink.</p> <p>Set the desired value of the chosen digit by pressing the <b>RST ▲</b> button. Depressing the <b>RST ▲</b> button will cause the value to auto scroll.</p>
(2) TOTALIZER DECIMAL POINT POSITION SETTING		When the display shows the Decimal Point Position setting screen, press the <b>RST ▲</b> button until the desired decimal point position is reached.
(3) RATEMETER PRESCALE SETTING	  	<p>When in the Ratemeter Prescale setting screen, when a <b>d</b> appears on the right most of the display, it is time to set the decimal point position for the prescale factor. Press the <b>RST ▲</b> button until decimal point is in desired position. Note: This decimal point is used only for the prescale factor and it will not appear on the ratemeter screen.</p> <p>Press the <b>T/R ◀</b> button to move the cursor to the next digit. Press the <b>RST ▲</b> button to set the desired value of a particular digit. Depressing this button will cause the value to auto scroll.</p>
(4) RATEMETER DECIMAL POINT POSITION SETTING		When the display shows the Decimal Point Position setting screen, press the <b>RST ▲</b> button until the desired decimal point position is reached.
(5) RATEMETER RATE DISPLAY MULTIPLIER (x1 / x10)		<p>When the display shows the Rate Display Multiplier setting screen, press the <b>RST ▲</b> button to select desired setting. Selecting x10 will add a zero on the last digit of the display. This zero will not change value and will not affect the decimal point position. When "1" is displayed, it is x1. When "10" is displayed, it is x10.</p>
(6) TOTALIZER FRONT RESET SETTING		<p>When the display shows the Front Reset setting screen, choose the desired setting of the Front Reset by pressing the <b>RST ▲</b> button. A <b>R</b> display indicates an enabled front reset. A <b>noR</b> display indicates a disabled front reset. Note: The remote reset is still active even if front reset setting is disabled.</p>

## CONNECTIONS

<p><b>Add Input (Voltage Input) G36-101,201,301</b></p> <p>Supply a Voltage pulse between terminal ③ and ① (GND) to count (measure).</p>	<p><b>Add Input (Contact/Open Collector Input) G36-101,201,301</b></p> <p>Connect or supply an Open Collector signal between terminal ② and ① (GND) to count (measure).</p>
<p><b>Add/Subtract Individual Input (Voltage Input) G36-104</b></p> <p>Supply a Voltage pulse between terminal ② and ① (GND) to Add, terminal ③ and ① (GND) to Subtract.</p>	<p><b>Add/Subtract Individual Input (Contact/Open Collector Input) G36-103</b></p> <p>Connect or supply an Open Collector signal between terminal ② and ① (GND) to Add, terminal ③ and ① (GND) to Subtract.</p>
<p><b>90° Quadrature Input (Voltage Input) G36-102</b></p> <p>Supply a 90° Quadrature Voltage pulse between terminal ③ (Signal A) and terminal ② (Signal B).</p>	<p><b>Programming Mode (except G36-101)</b></p> <p>Connect terminals ⑤ and ① (GND) to enter into Programming Mode.</p>
<p><b>Remote Reset (except G36-201)</b></p> <p>Connect terminals ④ and ① (GND) to reset the count.</p>	<p><b>Front Reset Enable/Disable (only for G36-101)</b></p> <p>Connect terminals ⑤ and ① (GND) to enable the Front Reset button. Disconnect to disable the Front Reset button.</p>

## CALCULATING THE PRESCALE FACTOR

The Prescale Factor is used to convert the incoming count pulses to the desired unit of measure to be displayed (meters, feet, liters, gallons, etc.) or to correct a known amount of error (wheel wear, viscosity, etc.)

<TOTALIZER>

Prescale Setting Range : 0.0001 ~ 99.9999  
(0.0000 setting will result to a scaling of 100)

Prescale Formula: 
$$PS = \frac{DPF}{PPR}$$

PS = Prescale  
DPF = Decimal Point Factor

x x . x x x x 1  
 x x x x x . x 10  
 x x x x . x x 100  
 x x x . x x x 1000  
 x x . x x x x 10000

PPR = Pulse per Revolution  
(based on sensor Output pulse)

Example: In a conveyor, a sensor produces 20 pulses per 1m movement. Determine the prescale factor when a 1/10 m display is required. The resulting PS based on the formula is as follows:

$$PS = \frac{10}{20} = 0.5000$$

<RATEMETER>

Prescale Setting Range : 0.001 ~ 9999  
(0.0000 setting not possible)

Prescale Formula: 
$$PS = \frac{SEC \times DPF}{PPR}$$

PS = Prescale  
DPF = Decimal Point Factor

x x x x 1  
 x x x . x 10  
 x x . x x 100  
 x . x x x 1000

SEC = No. of seconds in the rate time unit  
(i.e. items/second = 1, items/min = 60, items/hour = 3600, etc.)

PPR = Pulse per Revolution  
(based on sensor Output pulse)

Example: A sensor produces 1 pulse per 1m of material. Determine the rate prescale factor to display no. of items per minunte is required. The resulting PS based on the formula is as follows:

$$PS = \frac{60 \times 1}{1} = 60.00$$

## ■ DIMENSIONS

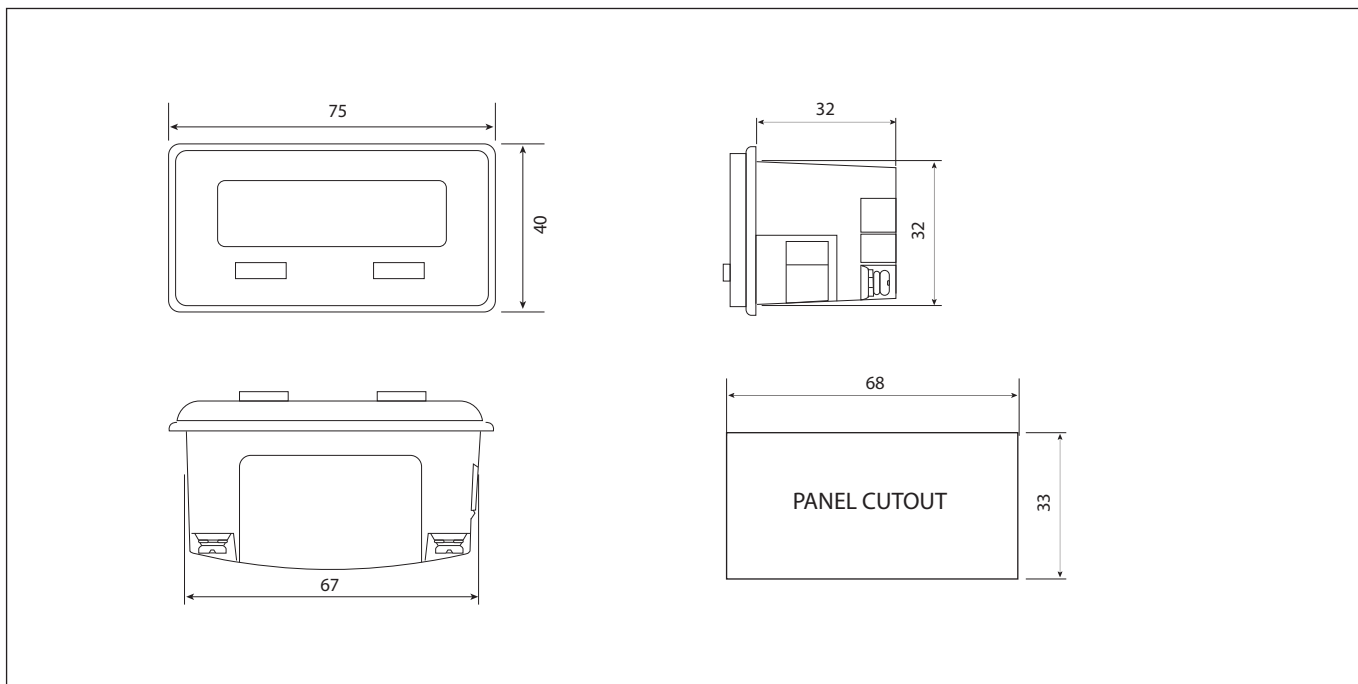

Specifications and printed contents subject to change without prior notice.  
All Rights Reserved, Copyright © 2006 LINE SEIKI CO., LTD. 1ST Edition.  
Last Revised March 4, 2006.



**LINE SEIKI CO.,LTD.**

Address : 37-7, Chuo-Cho, 2-Chome, Meguro-ku  
Tokyo 152-0001 JAPAN  
Contacts : Tel: +81-3-3716-5151 Fax: +81-3-3710-4552  
E-mail: sales@line.co.jp  
URL : <http://www.line.co.jp>



**ライン精機株式会社**

本社・東京営業所 〒152-0001 東京都目黒区中央町2-37-7  
TEL03-3716-5151(代) FAX03-3710-4552  
大阪営業所 〒550-0015 大阪市西区南堀江4-30-16  
TEL06-6538-0365(代) FAX06-6538-0315  
URL: <http://www.line.co.jp>