

# Automatic Media Take-up System Installation and Usage Manual



**Read the Manual Through Before Installation**

## **PREFACE**

Thank you for choosing this product. Here we extend our best regards to you and your company.

Please read this manual before the installation process, and keep it appropriately afterwards. This manual is edited by us and all rights reserved. The contents of this manual are subject to change without notice. Should any errors be detected, we would greatly appreciate being informed of them and the further amending or explanation would be edited in the new version.

Please entrust professionals with the installation of this product, or install it by yourself after carefully reading this manual to assure the proper installation and safety.

## **Warranty and Contacts**

We offer one year warranty to this product since you receive it. If you have any problem, please contact the local dealers in your country or contact us directly.

**Customer Service:**

**Please Keep Well of This Manual for Future Reference.**

# Auto Media Take-up System Installation Manual

1. Unpacking the Automatic Media Take-up System, make sure you have all the items show below:



- ① Take-up Drive Unit (Right Part)
- ② Bracket of Drive Unit
- ③ Bracket of Movable Unit
- ④ Take-up Movable Unit (Left Part)
- ⑤ Take-up Sensor
- ⑥ Small Parts Box: Screws and Blocking Clips
- ⑦ Power Cord
- ⑧ Left and Right Paper Stops (Flanges)

2. Remove the screws of the two brackets and prepare them as follow pictures:

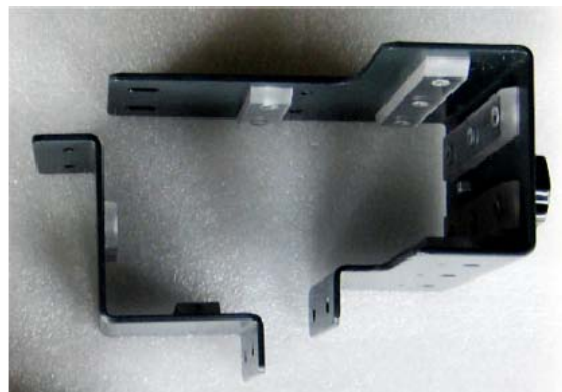
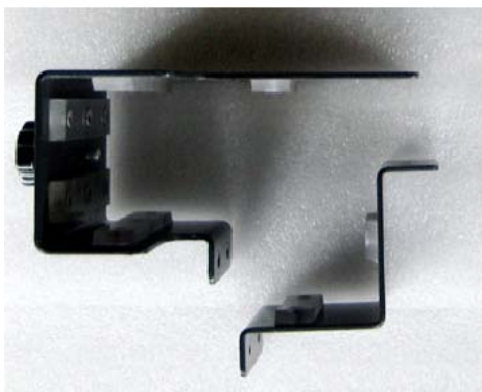

3. Using four screws to fix the Take-up Drive Unit and Movable Unit with their Brackets (Up Part) as follow pictures:

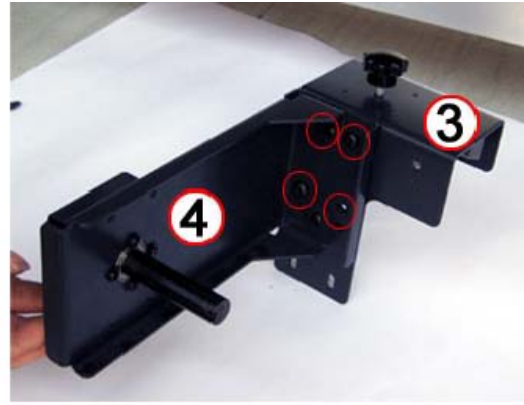
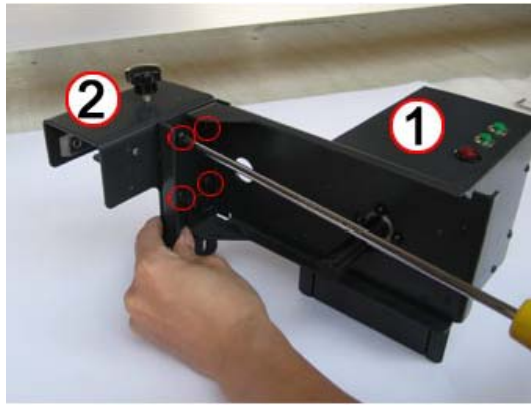

4. Hang the above two parts of Take-up System on the printer stand, fix them to the stand with the lower part of the Brackets as follow pictures:

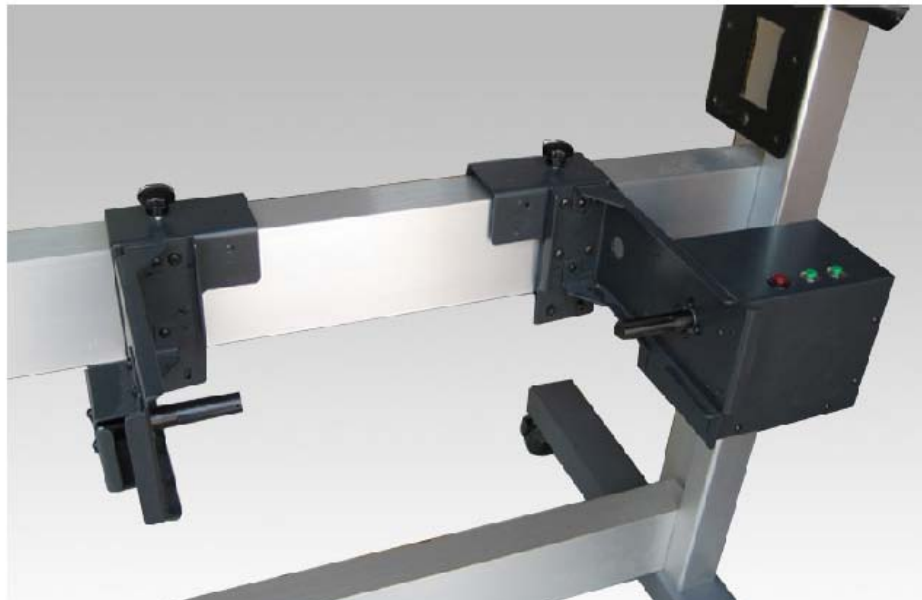
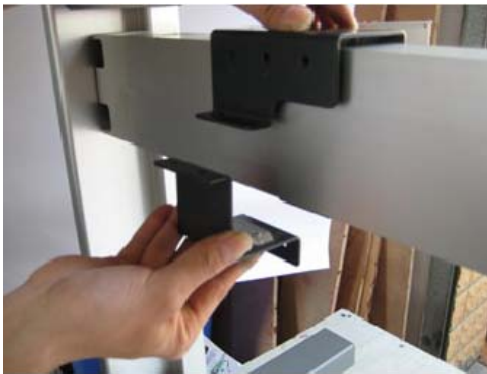

5. Attach the left and right Paper Stops (Flanges), using the Blocking Clips to prevent them from moving out:

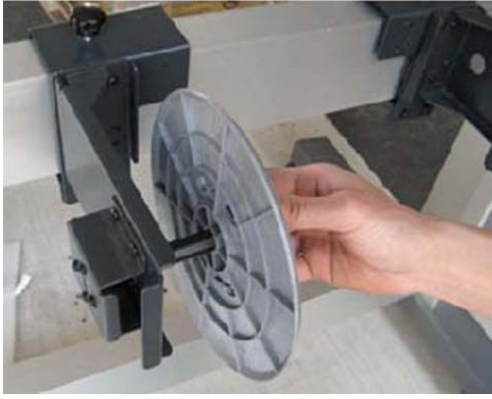

6. Attach the Take-up Sensor to the Right Bracket with two screws, and connect well the sensor cable and the Power Cord:

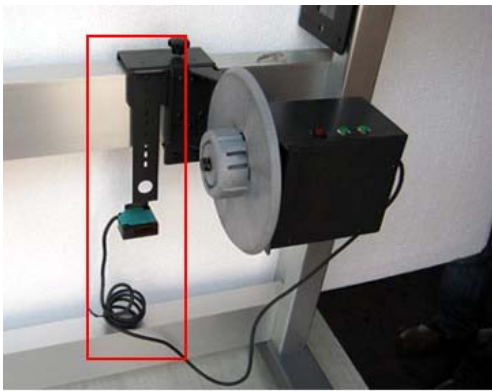

7. Well installed Take-up System is shown as below:



# Auto Media Take-up System Usage Manual

## 1. Button Description:

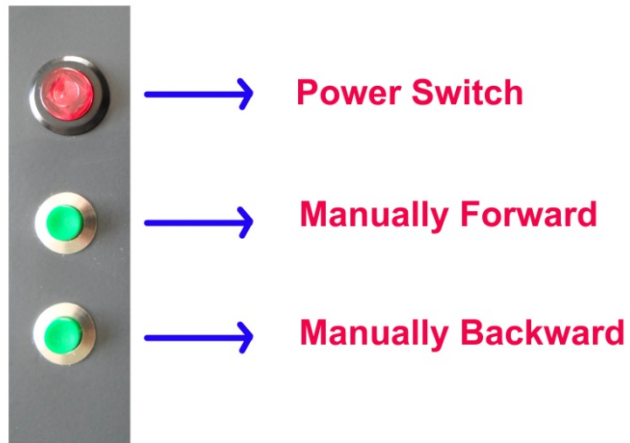

2. Attach a waste paper core to the Take-up System before printing. Slide the left part to fit the core width and strengthen the screws on the bracket to fix the position of the Take-up System.

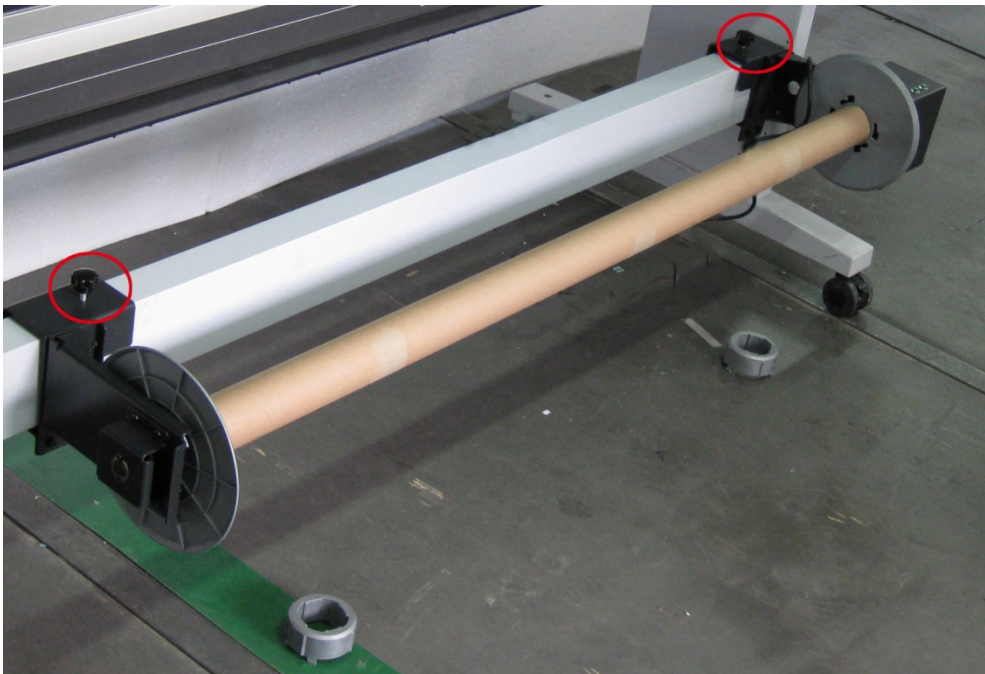

3. Change the adapter to suit the paper core of 3" or 2" Inner.

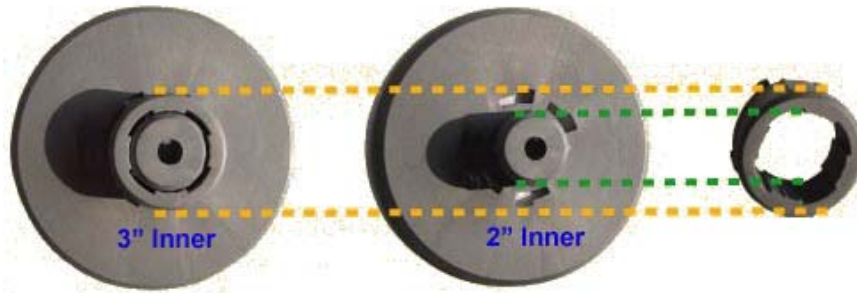

4. Press Power Switch to turn on the Take-up System, stick the end of the printing paper horizontally to the paper core. When the printing paper drop to the position in front of the sensor and block it, the Take-up System will run automatically.
5. Press the Manually Forward Button or Manually Backward Button to control the Take-up System manually.
6. If necessary, put a piece of waste paper core at the bottom of the printing paper to give tension of the rolling paper.

