

Tough and Reliable  
with Great Looks  
at a Low Cost

# Conventional Smoke Detector

● Model: ZC102

Compatible with all conventional Fire alarm control panel

## Dual LEDs

Two LEDs blink standby, provide 360° visibility

## Unique optical sensing chamber

Engineered to sense smoke by a wide range of combustion sources.

## Unpolarized wire input

To prevent the likelihood of wiring errors



## General Description

The device is photoelectronic detector uses a state of-the-art optical sensing chamber. This detector is designed to provide open area protection and to be used with most conventional fire alarm control panel.

Two LEDs on each detector provide local 360° visible alarm indication. They flash every 3~5 seconds indicating that power is applied and the detector is working properly. The LEDs latch on in alarm. LEDs will be off when a trouble condition exists indicating that the detector sensitivity is outside the listed limit. The detector can be reset only by a momentary power interruption.

## Features and Benefits

- Compatible with all the conventional fire alarm control panel
- Unpolarized wire input
- Wide range of operating voltages
- Unique optical sensing chamber
- Built in microprocessor intelligent software
- Two LEDs blink standby, provide 360° visibility
- Insect-resistant Screening
- Twist-on mounting base with tamper lock
- Drift compensation and smoothing algorithms
- Remote Indicator LED can be connected.



# Conventional Smoke Detector

## Installation Guidelines

All wiring must be installed in compliance with the National Electrical Code, applicable state and local codes, and any special requirements of the local Authority Having Jurisdiction.

Figure 1. Dimension of detector:

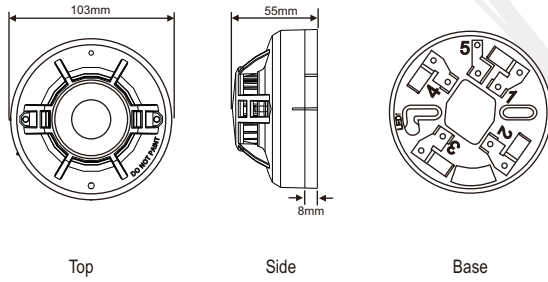

## Technical Specifications

Diameter: 103mm  
 Height (including mounting base): 55 mm  
 Weight: 155 g  
 Operating Temperature Range: -10°C to 50°C  
 Operating Humidity Range: 10% to 93% Relative Humidity, Noncondensing  
 Latching Alarm: Reset by momentary power interruption

### Electrical Ratings

System Voltage (nominal): 24 VDC (9V~ 28VDC)  
 Standby Current: 60 µA @ 24VDC  
 Alarm Current: 30 mA @ 24VDC

Figure 2. Wiring diagram for the detector:

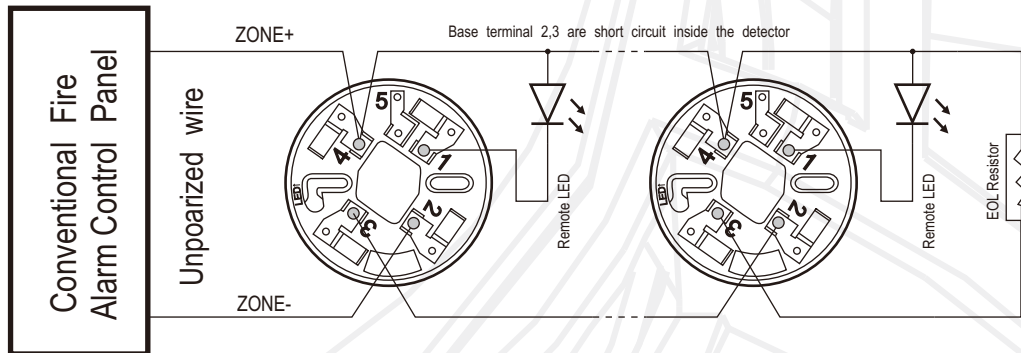

## Ordering Information

Part Number	Pack Quantity	Dimensions (w x d x h millimetres)	Weight
YT102	Individual (1 units)	103x103x55	155g

**Distributed by:**